

Regulators ICs for Digital Cameras and Camcorders

System Switching Regulator IC with Built-in FET (5V)



BD9355MWV

No.11036EAT15

●Description

7 Channel Switching Regulator Controller for Digital Camera that contains an internal FET.

Built in the function that dim a white LED for back light with a dimming set signal from a microcomputer.

●Features

- 1) 1.5V minimum input operating
- 2) Supplies power for the internal circuit by step-up converter(CH1).
- 3) CH1 step-up converter, CH2 cross converter, CH3,4 step-down converter, CH5 inverting converter for CCD, CH6 boost converter for CCD, CH7 boost converter for LED
- 4) All channels contain internal Power MOSFET and compensation.
Built-In Over Voltage Protection (OVP) for CH1,2,7
- 5) Operating frequency 2.0MHz(CH3,4), 1MHz(CH1,2,5~7)
- 6) Contains sequence control circuit for CH1~4. It is possible to select sequence CH1⇒CH3⇒CH4⇒CH2 and CH1⇒CH4⇒CH3⇒CH2 by SEQ_CTL pin
- 7) Built-In discharge switch (CH2,3,4) and contains off sequence control circuit for CH1~4.
CH1,3 turn off after CH2,4 output voltage discharged.
- 8) Built-In Short-circuit Protection (SCP)
- 9) CH1 have backgate control circuit CH6 have high side switches with soft start function.
- 10) Thermally enhanced UQFN036V5050 package(5mm□0.4mm pitch)

●Applications

For Digital Camera

●Absolute maximum ratings (Ta=25°C)

Parameter	Symbol	Ratings	Unit
Maximum applied power Supply voltage	HX2BAT,VCCOUT	-0.3~7	V
Maximum applied input voltage	VHx1~4, 56	-0.3~7	V
	(Hx56 - Lx5) Voltage	-0.3~15	V
	VLx6	-0.3~22	V
	VLx7	-0.3~30	V
Maximum Output current	IomaxHx1, Lx1	±2.2	A
	IomaxHx2	±1.5	A
	IomaxHx3	±1.2	A
	IomaxHx4	±1.0	A
	IomaxHx56	±1.5	A
	IomaxHS6L	+1.2	A
	IomaxLx7,8	±1.0	A
Power Dissipation	Pd	0.88 (*1)	W
Operating Temperature	Topr	-25~+85	°C
Storage Temperature	Tstg	-55~+150	°C
Maximum applied power Supply voltage	HX2BAT,VCCOUT	+150	°C

*1 Should be derated by 7.04mW/°C at Ta=25°C or more. When mounted on a glass epoxy PCB of 74.2mm×74.2 mm×1.6 mm

●Operating condition

Parameter	Symbol	Ratings			Unit	Conditions
		Min.	Typ.	Max.		
Power supply voltage	VBAT	1.5	-	5.5	V	
VREF terminal connection capacity	CVREF	0.047	0.1	0.47	μF	
PWM7 input frequency range	fpwm	20	-	100	kHz	
【Driver】						
CH1 NMOS/PMOS drain current	Idpl1	—	—	2.1	A	
CH2 Hx2BAT input current	Iin2	—	—	1.4	A	
CH3 PMOS drain current	Idpl3	—	—	1.0	A	
CH4 PMOS drain current	Idpl4	—	—	0.5	A	
CH5 PMOS drain current	Idpl5	—	—	1.4	A	
CH6 HS6L input current	Idpl6	—	—	1.1	A	
CH6,7 NMOS drain current	Idnl6,7	—	—	0.9	A	
【Output voltage setting range】						
CH1		4.5	—	5.4	V	
CH2		(※)	—	5.4	V	※Use with the following range.
CH3		1.0	—	4.4	V	
CH4		1.0	—	4.4	V	
CH5		-9.5	—	-1.5	V	
CH6		5.5	—	16	V	※Use with VBAT<Vo6
CH7		5.5	—	26	V	※Use with VBAT<Vo7

●CH2 output voltage setting range

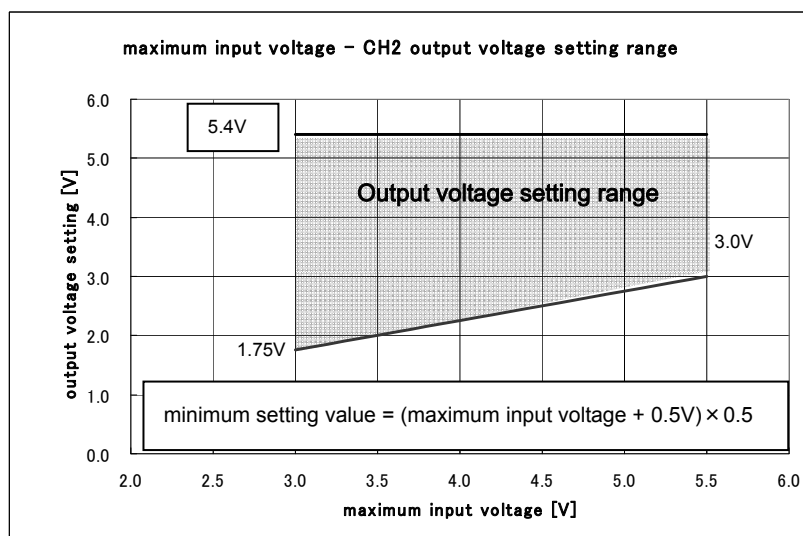

Fig.1 CH2 output voltage setting range

Ripple voltage level of CH2 cross converter would be big by cross talk with embedded oscillator when oscillating Duty of step down side is 50 %. Therefore please not to set oscillating duty of CH2 with 50%.

●Protective functions

Parameter	SCP	OCP	OVP	Conditions
CH1 step-up synchronous rectification	○	○	○	Stop when shorted output OVP: VCCOUT monitor
CH2 step-up voltage.	○	○	×	SCP:INV monitor
CH3 step-down synchronous rectification	○	○	×	SCP:INV monitor
CH4 step-up synchronous rectification	○	○	×	SCP:INV monitor
CH5 inverse Di rectification	○	○	×	SCP: Error amp output (internal node) monitor
CH6 step-up Di rectification	○	○	×	SCP: Error amp output (internal node) monitor
CH7 step-up back light	×	○	○	OVP:VO7 monitor

●Over current protective part

Parameter	Symbol	Limits			Unit	Conditions
		Min.	Typ.	Max.		
CH1 LX1 OCP detecting current	IOCP1	2.5	—	—	A	
CH2 HX2BAT OCP detecting current	IOCP2	2.0	—	—	A	
CH3 HX3 OCP detecting current	IOCP3	1.2	—	—	A	
CH4 HX4 OCP detecting current	IOCP4	1.2	—	—	A	
CH5 LX5 OCP detecting current	IOCP5	1.8	—	—	A	
CH6 HS6L OCP detecting current	IOCP6H	1.5	—	—	A	
CH6 LX6 OCP detecting current	IOCP6L	1.2	—	—	A	
CH7 Lx7 OCP detecting current	IOCP7	1.2	—	—	A	

●Recommended maximum load current

		Vo (V)	Vin (V)	Io_max (mA)	condition			Vo (V)	Vin (V)	Io_max (mA)	condition
CH1	Boost	5.0	1.8	400	L=4.3μH (TOKO:DE4518C) C=22μF R1=390 k Ω, R2=75k Ω	CH5	Reversal	-6.5	2.5	100	L=4.7μH (TOKO:DE2815) C=10μF R1=156k Ω, R2=30k Ω Cc=1000pF
			2.5	750					3.6	100	
			3.6	850					4.2	100	
			4.2	850					5.0	100	
CH2	Boost/ Step-down	3.2	1.8	300	L=4.7μH (TOKO:DE2815) C=10μF R1=440 k Ω, R2=200k Ω Cc=12pF	CH6	Boost	13	2.5	30	L=4.7μH (TOKO:DE2815) C=10μF R1=360k Ω, R2=30k Ω
			2.5	600					3.0	40	
			3.6	600					4.2	50	
			4.2	600					5.0	50	
CH3	Step down	1.2	1.8	800	L=4.7μH (TOKO:DE2815) C=10μF R1=300 k Ω, R2=600k Ω	CH7	Boost (worth 3 light LED)	11.4	1.8	25	L=4.7μH (TOKO:DE2815) C=4.7μF
			2.5	1000					2.5	40	
			3.6	1000					3.6	40	
			4.2	1000					4.2	40	
CH4	Step down	1.8	2.5	500	L=4.7μH (TOKO:DE2815) C=10μF R1=300 k Ω, R2=240k Ω	CH7	Boost (worth 4 light LED)	14	2.5	30	L=4.7μH (TOKO:DE2815) C=4.7μF
			3.0	500					3.6	40	
			3.6	500					4.2	40	
			4.2	500					5.0	40	

● **Electrical characteristics** (Unless specified, Ta=25°C, VCCOUT=5.0V, VBAT=3V, STB13~7=3V, UPIC8=2.5V)

Parameter	Symbol	Limits			Unit	Conditions
		Min.	Typ.	Max.		
【Low-voltage input malfunction prevention circuit】						
Detecting voltage	Vstd1	-	2.3	2.4	V	VCCOUT monitor
Release voltage	Vstd2	2.3	2.5	2.7	V	VCCOUT monitor
Hysteresis width	ΔV_{std}	100	200	300	mV	
【Short Circuit Protection】						
SCP detect time	Tscp	20	25	30	ms	
Timer start threshold voltage	Vtcinv	0.38	0.48	0.58	V	INV monitor CH2~4
【Start-up Circuit】						
Frequency	Fstart	150	300	600	kHz	HX2BAT=1.8V
Start-up HX2BAT Voltage	Vst1	1.5	-	-	V	
Start-up CH Soft Start Time	Tss1	1.8	3.0	5.3	msec	
【Oscillating circuit】						
Frequency CH3,4	fosc1	1.6	2.0	2.4	MHz	
Frequency CH1,2,5-7	fosc2	0.8	1.0	1.2	MHz	
Max duty 1(step-up)	Dmax1	81	86	90	%	
Max duty CH2 Lx21	Dmax21	-	-	100	%	
Max duty CH2 Lx22	Dmax22	81	86	90	%	
Max duty 3, 4(step-down)	Dmax34	-	-	100	%	
Max duty 5,6,7	Dmax567	81	86	90	%	
【Error Amp】						
Input Bias current	IINV	-	0	50	nA	INV1~7, NON5=3.0V
INV threshold 1	VINV1	0.79	0.80	0.81	V	CH1,3,4
INV threshold 2	VINV2	0.99	1.00	1.01	V	CH2,6
INV7 threshold 1	VINV71	570	600	630	mV	PWM7, Duty=100%
INV7 threshold 2	VINV72	436	450	473	mV	PWM7, Duty=75%
INV7 threshold 3	VINV73	223	240	257	mV	PWM7, Duty=40%
INV7 threshold 4	VINV74	15	30	45	mV	PWM7, Duty=5%
【For Inverting Base Bias Voltage Vref】						
CH5 Output Voltage	VOUT5	-6.072	-6.000	-5.928	V	NON5, 15k Ω , 72k Ω
Line Regulation	DVLI	-	4.0	12.5	mV	VCCOUT=2.8~5.5V
Output Current When Shorted	Ios	0.2	1.0	-	mA	Vref=0V
【Soft Start】						
CH2,5,6 Soft Start Time	Tss2,5,6	3.1	5.3	7.4	msec	
CH3,4 Soft Start Time	Tss3,4	1.2	2.1	3.0	msec	
CH7 Duty Restriction time	TDTC	5.0	8.2	11.8	msec	

(*) Recommend resistor value over 20k Ω between VREF5 to NON5, because VREF5 current is under 100 μ A.
This product is not designed for normal operation with in a radioactive environment.

●Electrical characteristics (Ta=25°C, VCCOUT=5.0V, HX,HX2BAT=3.6V, STB1~6=3V,PWM7=2.5V)

Parameter	Symbol	Limits			Unit	Conditions	
		Min.	Typ.	Max.			
【Output Driver】							
CH1 High side SW ON Resistance	RON1P	-	100	150	mΩ	Hx1=5V	
CH1 Low side SW ON Resistance	RON1N	-	60	120	mΩ	VCCOUT=5.0V	
CH2 Lx21 High side SW ON resistance	RON21P	-	120	180	mΩ	Hx2BAT=3.6V	
CH2 Lx21 Low side SW ON resistance	RON21N	-	120	180	mΩ	VCCOUT=5.0V	
CH2 Lx22 High side SW ON resistance	RON22P	-	120	180	mΩ	VOUT2=3.6V	
CH2 Lx22 Low side SW ON resistance	RON22N	-	100	150	mΩ	VCCOUT=5.0V	
CH3 High side SW ON Resistance	RON3P	-	150	230	mΩ	Hx3=3.6V , VCCOUT=5V	
CH3 Low side SW ON Resistance	RON3N	-	120	180	mΩ	VCCOUT=5.0V	
CH4 High side SW ON Resistance	RON4P	-	200	300	mΩ	Hx4=3.6V, VCCOUT=5V	
CH4 Low side SW ON Resistance	RON4N	-	150	230	mΩ	VCCOUT=5.0V	
CH5 PMOS SW ON resistance	RON5P	-	450	700	mΩ	Hx56=3.6V	
CH6,7 NMOS SW ON resistance	RON6,7N	-	500	750	mΩ	VCCOUT=5.0V	
CH6 Load SW ON resistance	RON6P		150	230	mΩ	Hx56=3.6V	
LED PIN SW ON resistance	RLED	-	2.0	3.0	Ω	VCCOUT=5.0V	
【Discharge switch】							
CH2 discharge SW ON resistance	RDSW2	-	500	1000	Ω	VCCOUT=5.0V	
CH3 discharge SW ON resistance	RDSW3	-	500	1000	Ω	VCCOUT=5.0V	
CH4 discharge SW ON resistance	RDSW4	-	500	1000	Ω	VCCOUT=5.0V	
【STB1~6】							
STB Control Voltage	Active	VSTBH1	1.5	-	5.5	V	
	Non Active	VSTBL1	-0.3	-	0.3	V	
Pull Down Resistance		RSTB1	250	400	700	kΩ	
【PWM7】							
PWM7 Threshold		VPWM7	1.1	1.5	1.9	V	
Pull Down Resistance		RPWM7	250	400	700	kΩ	
CH7 Delay time for shutdown		Toff7	200	300	-	usec	
【Circuit Current】							
Stand-by Current	VCCOUT terminal	ISTB1	-	-	5	μA	
	Hx terminal	ISTB2	-	-	5	μA	Step-down Cross- converter
	Lx terminal	ISTB3	-	-	5	μA	Step-up
Circuit Current when start-up (HX2BAT current when voltage supplied for the terminal)		IST	-	150	450	μA	HX2BAT=1.5V
Circuit Current (VCCOUT current when voltage supplied for the terminal)		Icc2	-	5.0	9.7	mA	INV1~7=1.2V , NON5=-0.2V

This product is not designed for normal operation with in a radioactive environment.

●Reference data (1)

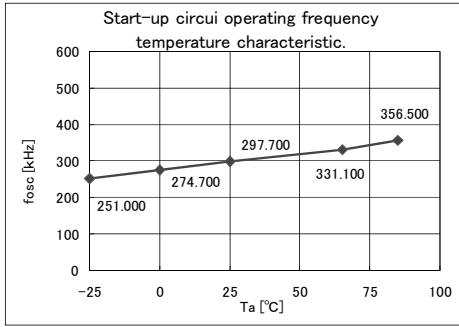

Fig.2 Start-up circuit frequency-Temp

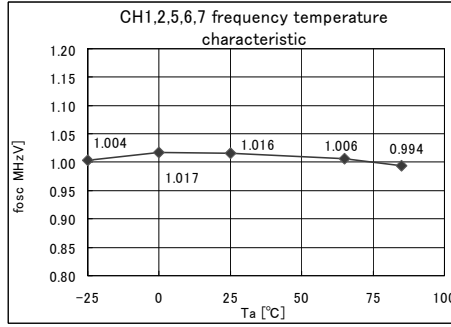

Fig.3 Frequency CH1,2,5~7-Temp

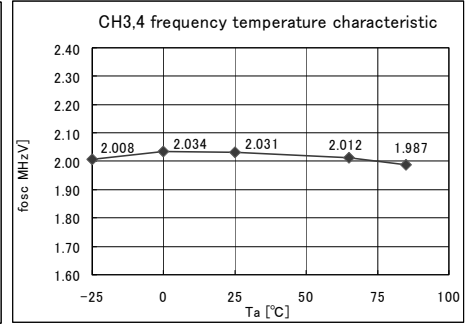

Fig.4 Frequency CH3,4-Temp

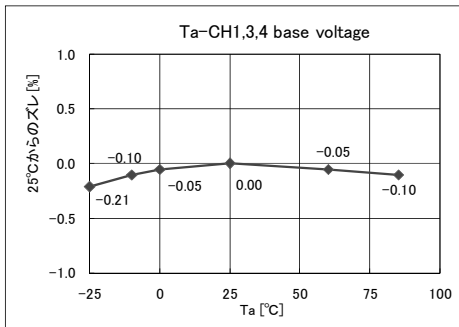

Fig.5-1 CH134 Base voltage-Temp

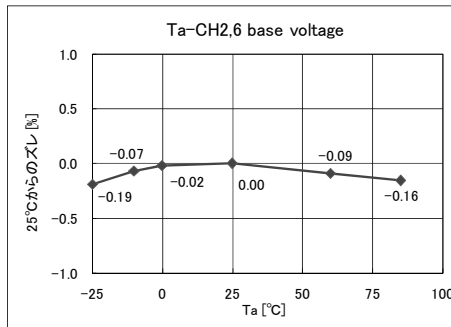

Fig.5-2 CH26 Base voltage-Temp

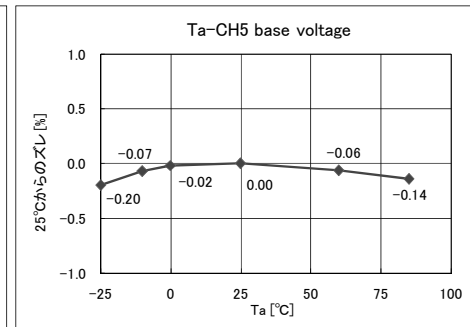

Fig.5-3 CH5 Base voltage-Temp

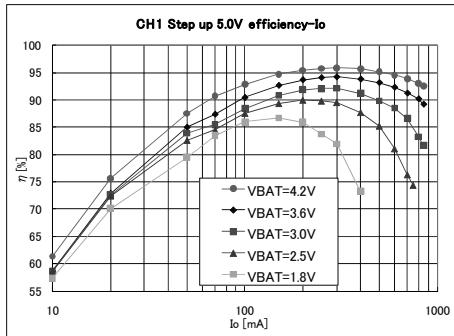

Fig.6 CH1 5.0V voltage boost efficiency-Io

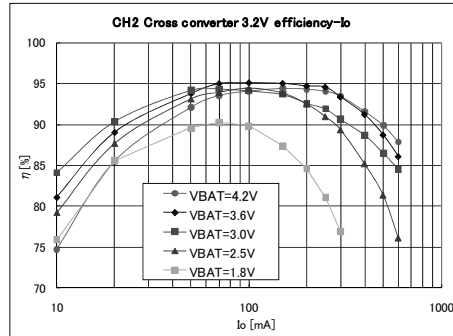

Fig.7 CH2 3.2V voltage boost efficiency-Io

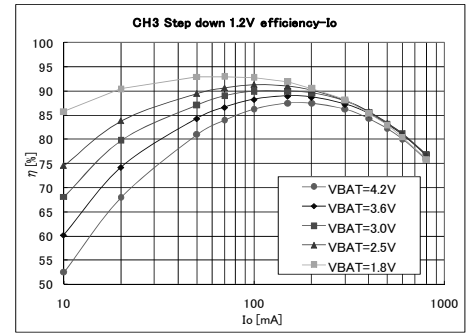

Fig.8 CH3 1.2V step-down efficiency-Io

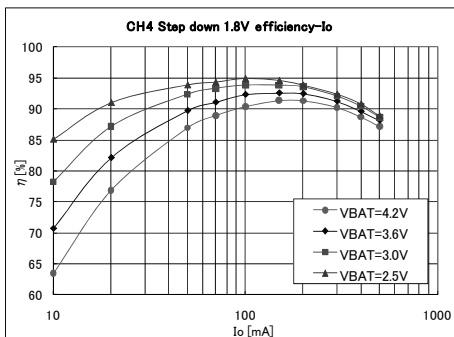

Fig.9 CH4 1.8V step-down efficiency-Io

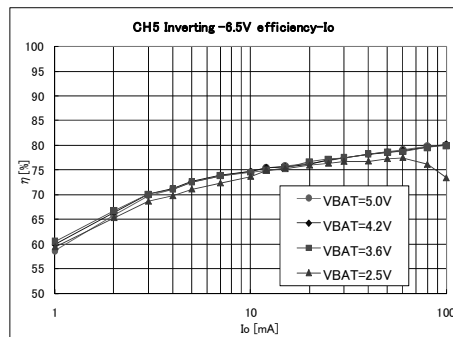

Fig.10 CH5 -6.5V inverting efficiency-Io

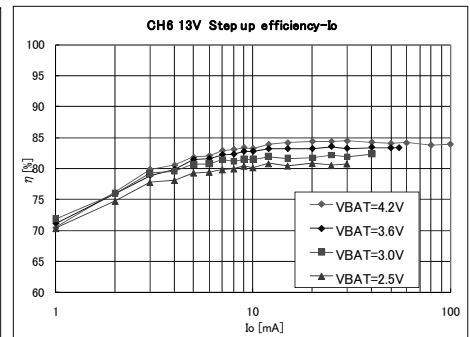

Fig.11 CH6 13V boost efficiency-Io

●Reference data (2)

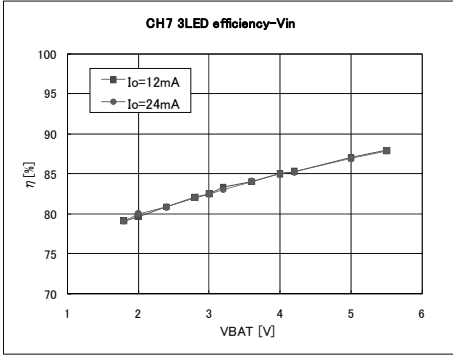

Fig.12 CH7 3LED Efficiency— Input voltage

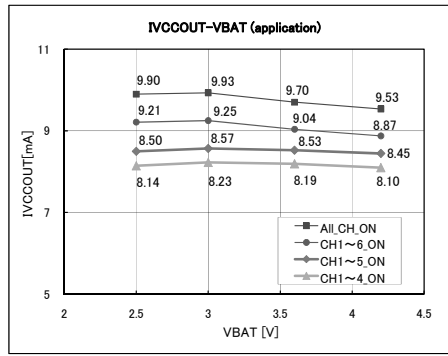

Fig.13 IVCCOUT-VBAT (Recommended application)

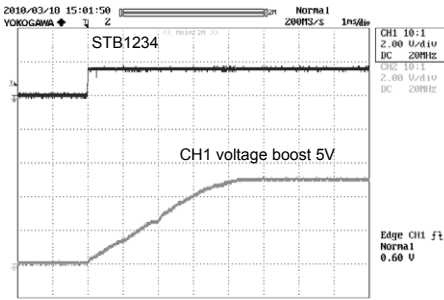

Fig.14 CH1 start-up waveform (VBAT=1.5V)

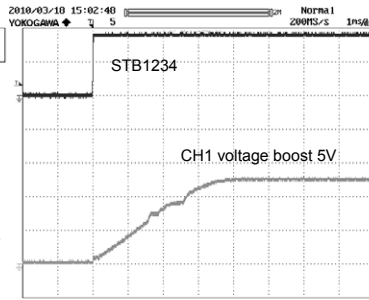

Fig.15 CH1 start-up waveform (VBAT=3.6V)

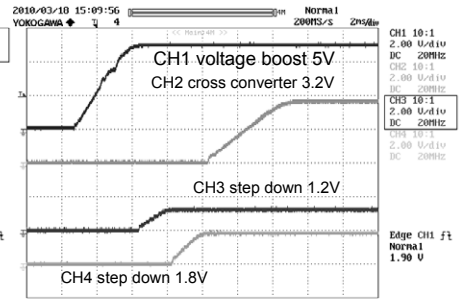

Fig.16 CH2~CH4 start-up waveform (SEQ_CTL=L)

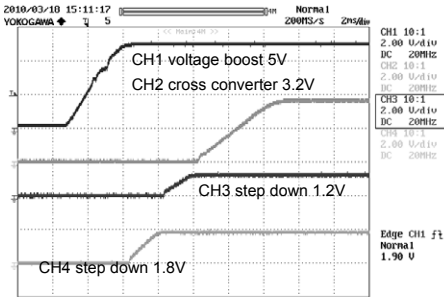

Fig.17 CH2~CH4 start-up waveform (SEQ_CTL=H)

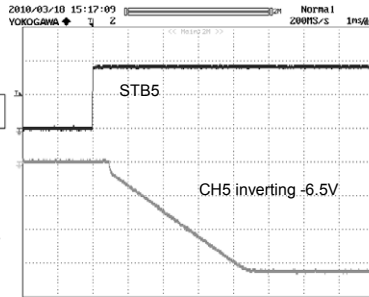

Fig.18 CH5 start-up waveform

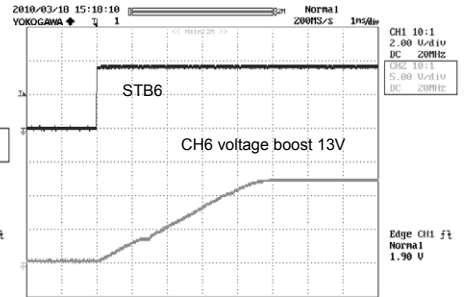

Fig.19 CH6 start-up waveform

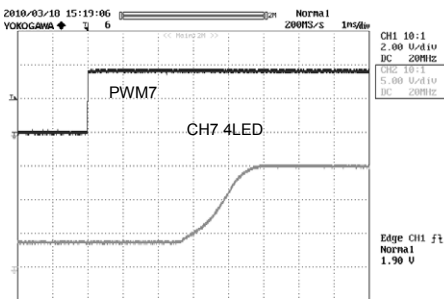

Fig.20 CH7 start-up waveform

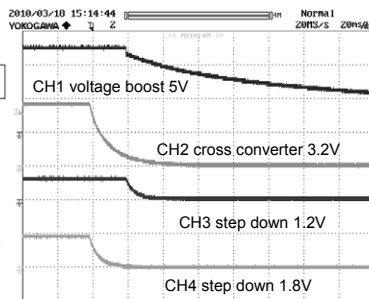

Fig.21 CH1~4 waveform when OFF (SEQ_CTL=H/L common)

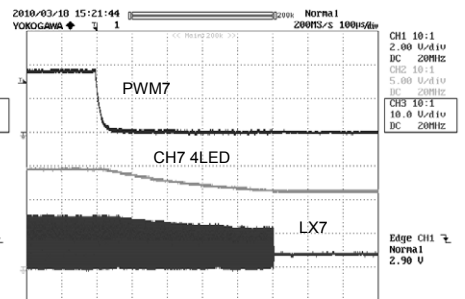

Fig.22 CH7 waveform when OFF

●Block Diagram

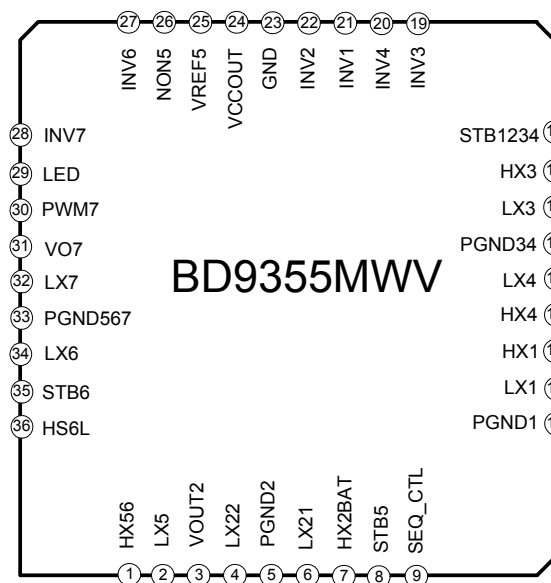

Fig.23 BD9355MWV Top VIEW

●Pin description

Pin No	Pin name	I/O	Function	note
24	VCCOUT	I	IC Power Supply Input	Part of controller Power Supply for Low side Driver
23	GND	O	Ground terminal	
10,5,15,33	PGND1,2,34,567	O	Ground for Internal FET	
25	VREF5	O	CH5 Reference Output	
12	Hx1	O	Step up output voltage terminal (Contains backgate control)	
17,7,13,1	HX3,2BAT,4,56	I	CH2-6 Pch FET Source Terminal , FET Driver Power Supply	
11,16,14,2,34,32	Lx1,3,4,5,6,7	I/O	Terminal for Connecting Inductor	
6	Lx21	I/O	Terminal for Connecting Inductor For CH2 Input	
4	Lx22	I/O	Terminal for Connecting Inductor For CH2 Output	
3	VOUT2	O	CH2 DC/DC Output	
36	HS6L	O	Output Terminal for Internal Load Switch	
21,22,19,20,27,28	INV1,2,3,4,6,7	I	Error Amp Inverted Input	
26	NON5	I	Error Amp Non-inverted input	
18,8,35	STB1234,5,6	I	ON/OFF switch H: operating over 1.5V	
30	PWM7	I	CH7 ON/OFF Control, PWM Dimming Input	
9	SEQ_CTL	I	Sequence control terminal	GND:CH1→CH3→CH4→CH2 VCCOUT:CH1→CH3→CH4→CH2
29	LED	I	Terminal for connecting LED Cathode	
31	VO7	I	CH7 DC/DC Output	

●Application circuit(1)

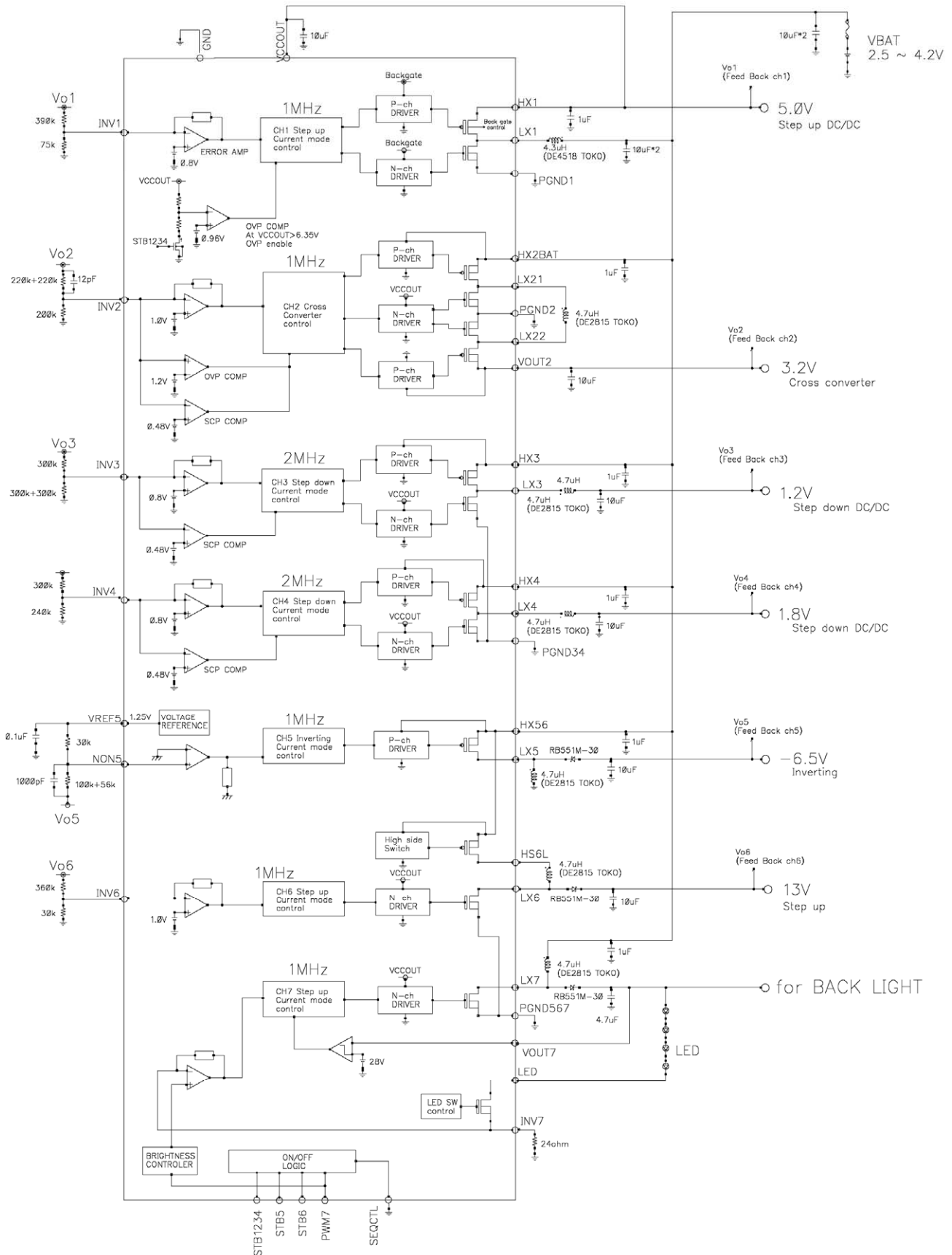

Fig.24 Applied circuit diagram 1(lithium 1 cell)

○Operation notes

- we are confident that the above applied circuit diagram should be recommended, but please thoroughly confirm its characteristics when using it. In addition, when using it with the external circuit's constant changed, please make a decision that allows a sufficient margin in light of the fluctuations of external components and ROHM's IC in terms of not only static characteristic but also transient characteristic.

●Application circuit (2)

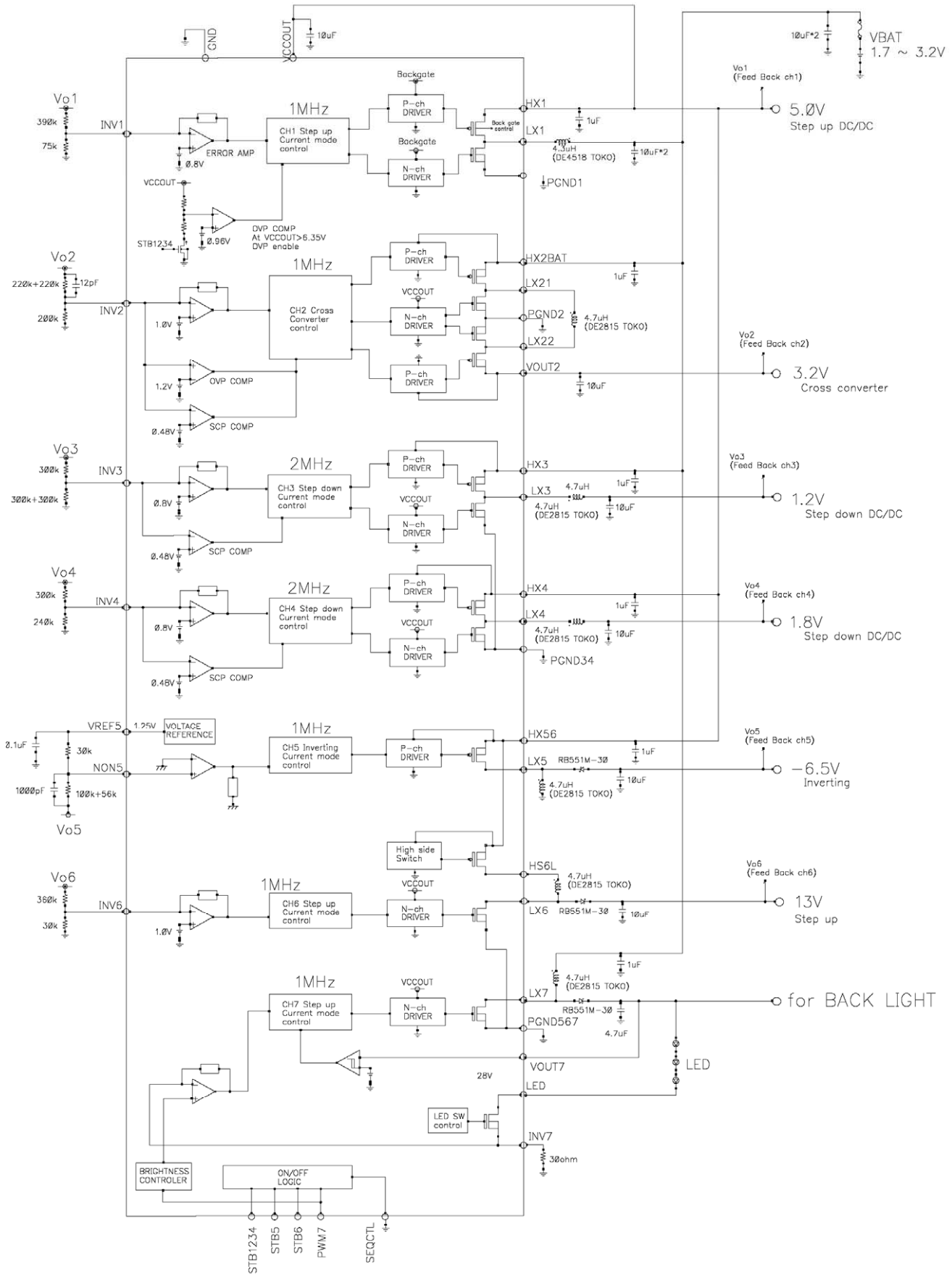

Fig.25 Applied circuit diagram 2(dry battery x2)

○Operation notes

- we are confident that the above applied circuit diagram should be recommended, but please thoroughly confirm its characteristics when using it. In addition, when using it with the external circuit's constant changed, please make a decision that allows a sufficient margin in light of the fluctuations of external components and ROHM's IC in terms of not only static characteristic but also transient characteristic.

●Timing chart (1)

SEQ_CTL=L (GND)

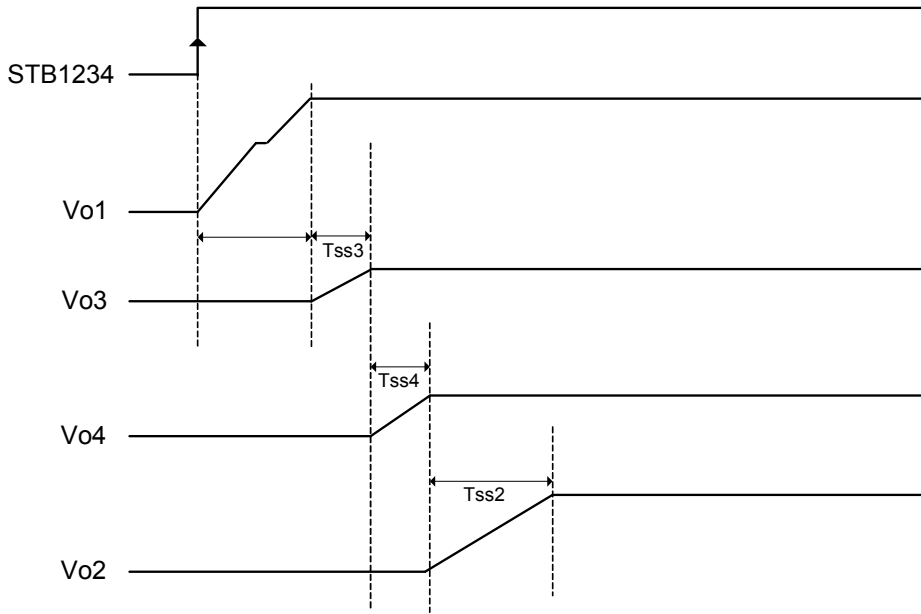

SEQ_CTL=H (VCCOUT)

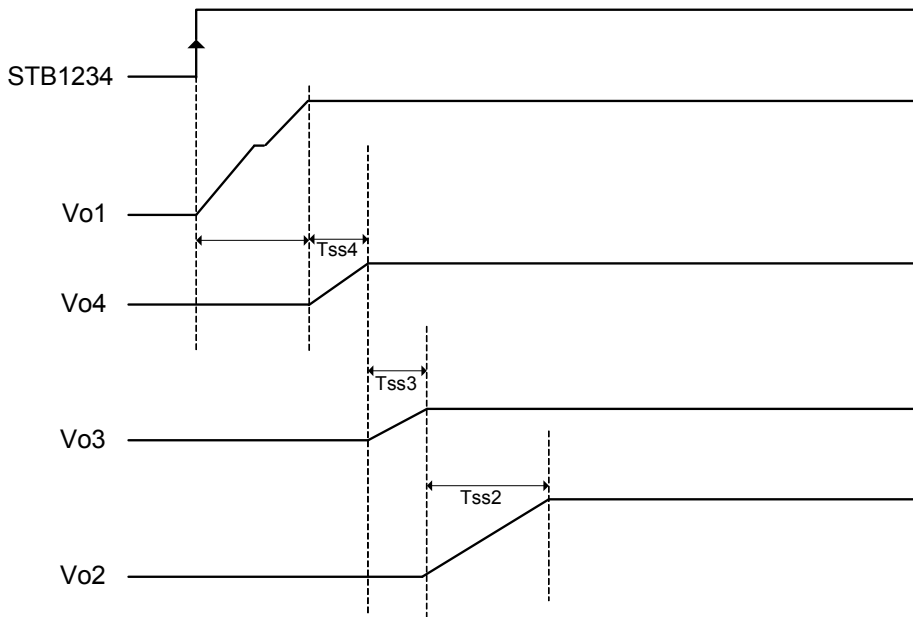

Fig.26 CH1~4 start-up sequence

●Timing chart (2)

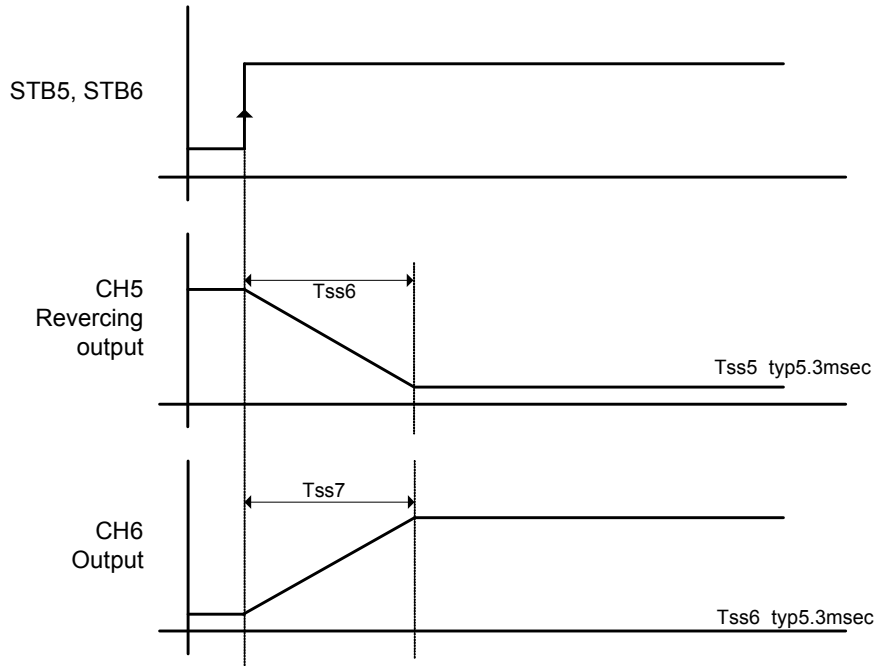

Fig.27 CH5,6 start-up sequence

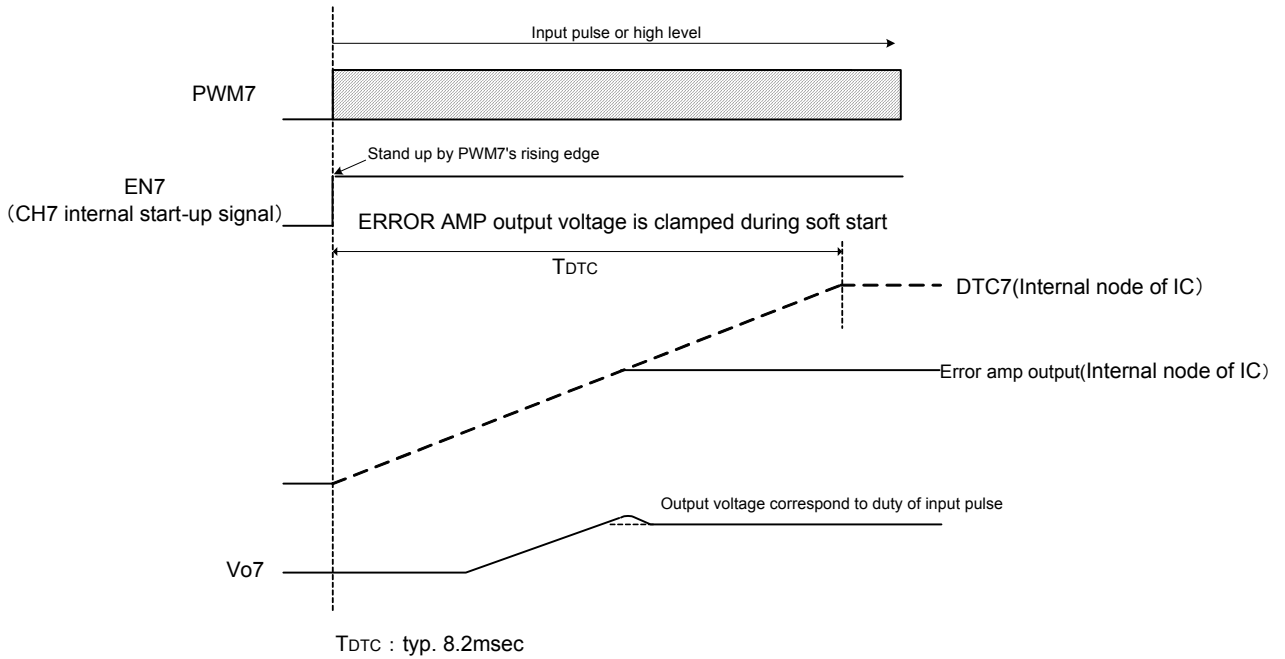

Fig.28 CH7 start-up sequence

●Timing chart (3)

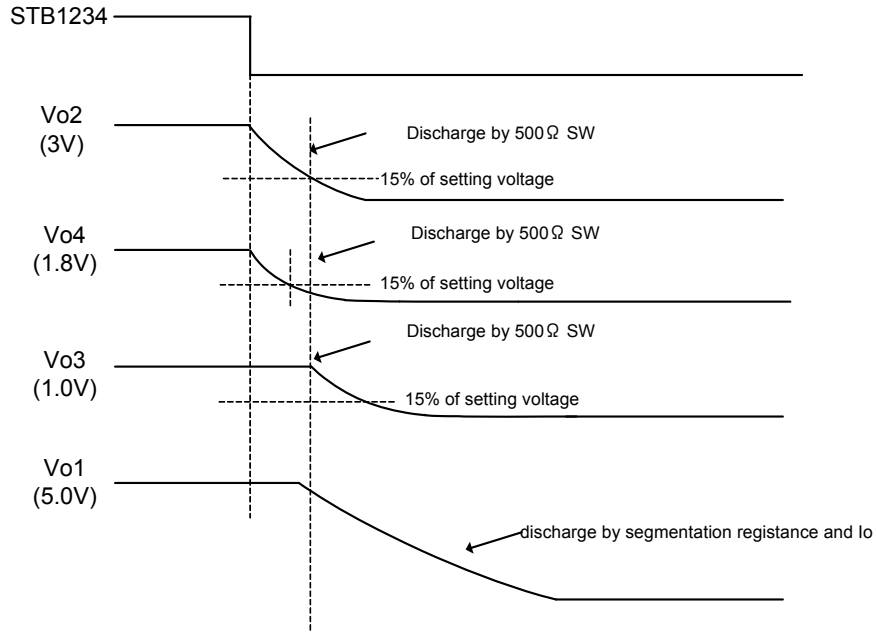

Fig.29 CH1~4 OFF sequence

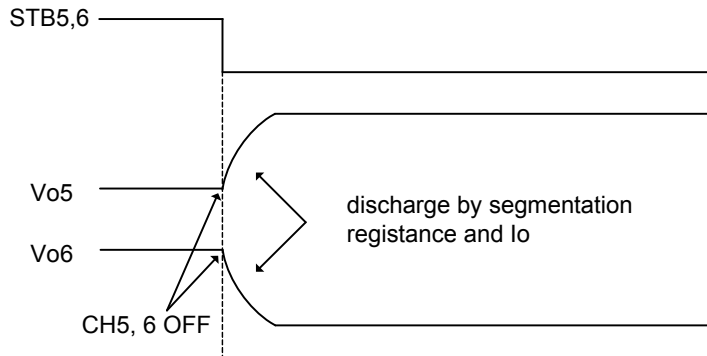

Fig.30 CH5,6 OFF sequence

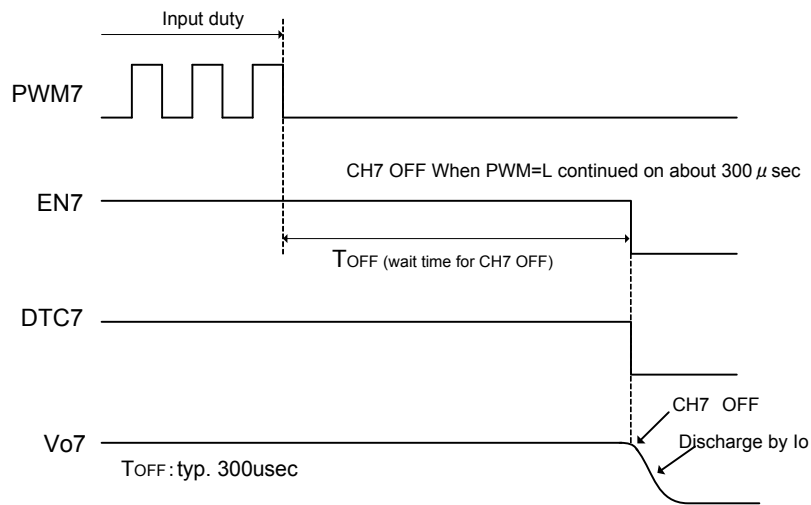

Fig.31 CH7 OFF sequence

●CH7 dimming function

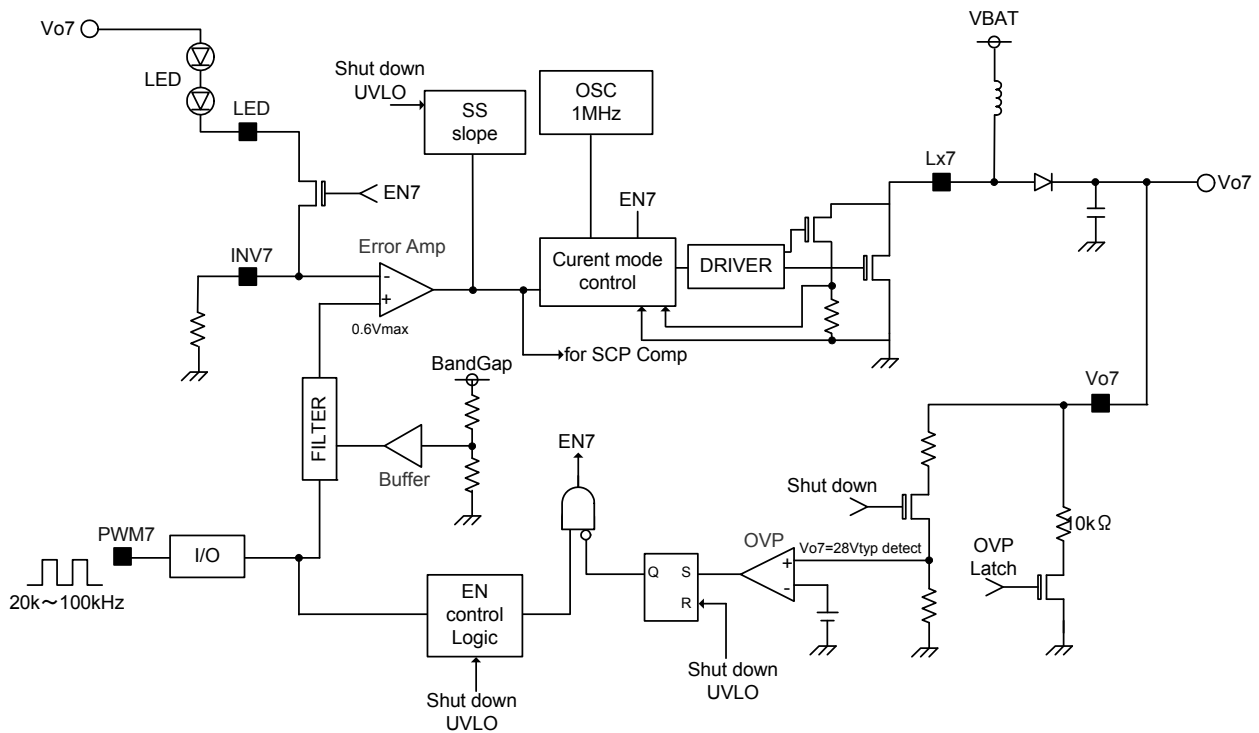

Fig..32 CH7 block diagram

●CH7 operation

The output duty control signal for soft start starts rising by connecting terminals LED and INV7 when inputting any Duty for PWM7. And threshold voltage of erroramp being proportional to PWM7 Duty is supplied by PWM7 input signal after start up, then INV7 output voltage being proportional to PWM7 Duty is supplied as the result of negative feedback of DCDC converter. DTC7 rises up slower comparatively with oscillating frequency by fixed degree incline. Oscillating duty is restricted by DTC7 signal which is inputted to PWM comparator therefore input rush current is prevented to occur even output voltage of erroramp at start up time rises up rapidly. The time from start up to reaching set current of LED is depend on input voltage, a number of LED, PWM7 duty, resistor to set the current of LED. The time to reach set current of LED will be long when input voltage is low, a number of LED is big, set output current is big because of high duty under that condition. When you input L voltage into PWM7 pin during over 500 μ sec typ, Switch between LED and INV7 and switching turn off. CH7 have Over voltage protection(OVP).When VO7 pin is over 28Vtyp,OVP stop CH7 function..OVP latch CH7 function and reset by All STB=L.

●Attention of CH7 start-up

In case CH7 start up, Please turn on STB1234 before CH7.CH7 can not start before CH1,2,3,4

●Recommended method of setting at the time of INV7 output voltage setting.

If INV7 output setting value is made larger than previous setting value during all intervals but soft start interval (at the time of starting up), it is recommended that the value of voltage is increased step by step with the smallest possible width of step after fully evaluating the restriction at the soft side that controls rush current and switching and the vision of brightness etc. in terms of set application.

OPWM7 Duty INV7 Voltage Value

INV7 is output voltage that proportionate to PWM7 input PWM pulse DUTY and control LED current by external resister for setting (between INV7 and GND). LED current is decided by NOTE1 formula.

(Note 1) LED current = INV7 voltage / resistance R for LED current setting

PWM7 InputDUTY[%]	INV7 Output Voltage [mV]
5	30
10	60
15	90
20	120
25	150
30	180
35	210
40	240
45	270
50	300
55	330
60	360
65	390
70	420
75	450
80	480
85	510
90	540
95	570
100	600

Fig.33 PWM7 DUTY – INV7 Terminal Voltage

●Block explanation

1. SCP, Timer Latch

It is a timer latch type of short-circuit protection circuit.

For CH1,2, 6~8, the error AMP output voltage is monitored, and detected when the feedback voltage deviates from control, for CH3~5, it is detected when the voltage of INV terminal becomes lower than 60%, and in 25ms the latch circuit operates and the outputs of all the channels are fixed at OFF.

In order to reset the latch circuit, please turn off all the STB terminals before turning them on once again or turning power supply on once again.

2. U.V.L.O

It is a circuit to prevent malfunction at low voltage.

It is to prevent malfunction of internal circuit at the time of rising or dropping to a lower value of power supply voltage. If the voltage of VCCOUT terminal becomes lower than 2.3V, then the output of each DC/DC converter is reset to OFF, and SCP's timer latch & soft start circuit are reset. When control is deviated from, the operation of CH1 at the time of start-up will be explained in START UP OSC mentioned later.

3. Voltage Reference (VREF5)

For the reference voltage circuit of CH5 inversion CH, the output voltage is 1.25V and outputted from VREF5 terminal (25pin). According this voltage and the output voltage of CH5, the dividing resistance (resistor) is set and then the output voltage is set.

If STB5 terminal is made to be H level at the time of start-up, then increase gradually the voltage up to 1.25V. The inversion output of CH5 follows this voltage and performs the soft start. 0.1 μ F is recommended as the external capacitor.

4. OSC

It is an oscillation circuit the frequency of which is fixed by a built-in CR.

The operating frequencies of CH3, 4 are set at 2MHz, and the operating frequencies of CH1, 2, 5 are set at 1MHz.

5. ERRAMP 1~7

It is an error amplifier to detect output signal and output PWM control signal. The reference voltages of ERRAMP (Error Amplifier) of CH1, 3, 4 are internally set at 0.8V, and the reference voltages of ERRAMP (Error Amplifier) of CH2,6 are set at 1.0V. The reference voltage of CH5 is set at GND potential, and for CH7's ERRAMP7, the maximum value of the reference voltage is set at 0.6V. In addition, each CH incorporates a built-in element for phase compensation.

6. ERRCOMP, Start Up OSC

It is a comparator to detect the output voltage and control the start circuit, and also an oscillator that is turned ON/OFF by this comparator and starts operating from 1.5V. The frequency of this oscillator is about 300 kHz fixed internally. This oscillator stops operating if VCC terminal becomes more than 2.5V or the soft start time is exceeded.

7. Current mode control block

CH1, 3~7 adopt the PWM method based on current mode.

For a current- mode DC/DC converter, FET at the main side of synchronous rectification is turned on when detecting the clock edge, and turned off by detecting the peak current by means of the current comparator.

8. Cross Control

DUTY controller for CH2 cross converter. It have PWM comparator that compare 1MHz SLOPE and ERROR AMP output and logic circuit for control 4 FET ON/OFF switching.. LX21 MAX ON DUTY is 100%, LX21 MAX ON DUTY is 86%.

9. Back gate Control

PchFET backgate selector controller in CH1.

PchFET have body Di between backgate and source, drain ordinary. This circuit intercept CH1 step up output voltage by cutting body Di line at STB OFF and control soft start .CH1 softstart output voltage from 0V like a slope.

10. Nch DRIVER, Pch DRIVER

Internal Nch, Pch FET driver CMOS inverter type output circuit.

11. Load SW

It is a circuit, mounted in CH6, to control the Load SW. Hx56 terminal (1pin) is input terminal, and the HS6L terminals (36pin) are output terminals.

This control circuit can prevent the rush current at the time of SW ON because the soft start starts functioning at the time of start-up. In addition, this Load SW is provided with OCP function to prevent the IC from damage.

Ensure that the IC is used within Load SW's rated current when used normally.

12. ON/OFF LOGIC

It is the voltage applied to STB terminal and can control the ON/OFF of CH1~CH6.

If the voltage more than 1.5V is applied, then it becomes ON, but if open or 0V is applied, then it becomes off, furthermore, if all the channels are turned off, then the whole IC will be in standby state. In addition, STB1, 2, 3, 4~STB6 terminals contain respectively a built-in pull-down resistor of about 400kΩ.

PWM7 is the input terminal of the start signal and the light control signal of CH7. It becomes high if the voltage more than 2.1V is applied and becomes Low if the voltage less than 0.4V is applied. In addition, PWM7 terminal contains a built-in pull-down resistor of about 400kΩ.

13. SOFT START

It is a circuit to apply the soft start to the output voltage of DC/DC converter and prevent the rush current at the start-up.

Soft start time varies with the channels.

- a. CH1 reaches the target voltage in 3.0ms.
- b. CH3,4 reach the target voltage in 2.1ms.
- c. CH2,5,6 reach the target voltage in 5.3ms.
- d. CH7 reach the target voltage in 8.2ms.

14. Brightness controller

CH7 have LED brightness controller. INV7 is output voltage that proportionate to PWM7 input DUTY and control LED current by external resistor for setting (between INV7 and GND).

15. OVP COMP7

In CH7, When LED is OPEN, INV7 become L and output voltage increase suddenly. If this condition continues, Lx7 voltage increase and exceed break down voltage. CH7 have Over voltage protection (OVP). When VO7 pin is inputted over 28Vtyp, OVP stop CH7 function..OVP latch CH7 function and reset by All STB=L

● Setting method of IC peripheral components

(1) Design of feedback resistor constant

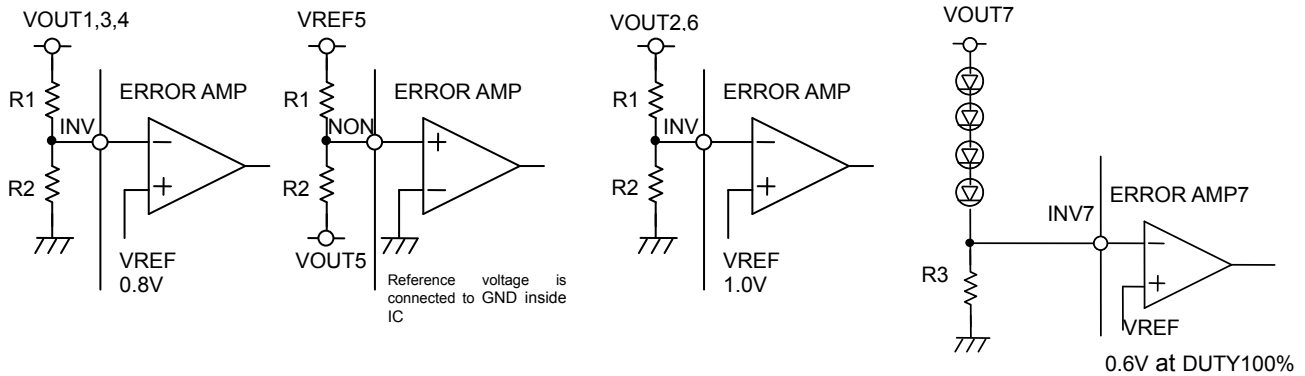

CH1,3,4 output voltage

$$V_o = \frac{(R1+R2)}{R2} \times 0.8 \text{ [V]} \dots (1)$$

CH5 output voltage

$$V_o = - \frac{R2}{R1} \times 1.25 \text{ [V]} \dots (2)$$

CH2,6 output voltage

$$V_o = \frac{(R1+R2)}{R2} \times 1.0 \text{ [V]} \dots (3)$$

CH7 output voltage

$$I_o = \frac{INV7}{R3} \text{ [A]} \dots (4)$$

Fig.34 Feedback resistor setting method

(a) CH1,3,4 setting

The reference voltage of CH1,3,4 ERROR AMP is 0.8V. Please refer to Formula (1) in Fig.33 for determining the output voltage.

This IC incorporates built-in phase compensation. Please refer to Applied Circuit Diagram for setting the values of R1 & R2 and ensure that the setting values of R1 & R2 are of the order of several hundred kΩ.

(b) CH5 setting

The reference voltage of CH5's ERROR AMP is connected to GND inside the IC. Therefore, a high-accuracy regulator can be configured if setting by the feedback resistance between the outputs of VREF and CH5 as shown in Fig.33. Please refer to Formula (2) in Fig.33 for determining the output voltage. R1 is recommended as more than 20kΩ because the current capacity of VREF5 is about 100μA.

(c) CH2,6 setting

The reference voltage of CH7's ERROR AMP is 1.0V. Please refer to Formula (3) in Fig.33 for determining the output voltage.

(d) CH7 setting

LED current is decided by Fig.33 (4) formula. Please decide R3 value for LED current range.

(2) Points for attention in terms of PCB layout of base-plate

○ For a switching regulator, in principle a large current transiently flows through the route of power supply – coil – output capacitor. Ensure that the wiring impedance is lowered as much as possible by making the pattern as wide as possible and the layout as short as possible.

○ Interference of power supply noise with feedback terminals (INV1~7, NON5) may cause the output voltage to oscillate. Ensure that the power supply noise's interference is avoided by making the wiring between feedback resistor and feedback terminal as short as possible.

●PIN equivalent circuit

INV1~INV6
(Error amplifier's inversion input)

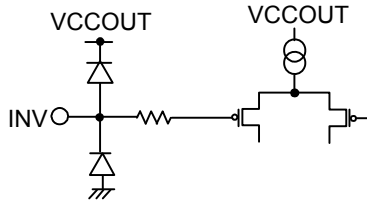

NON5
(Error amplifier's non-inversion input)

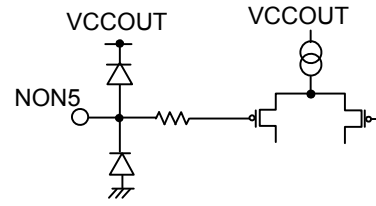

STB1234
(operating when CH1~4 ON/OFF switch is High)

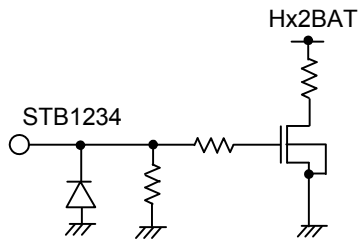

STB5,6
(operating when CH5,6 ON/OFF switch is High)

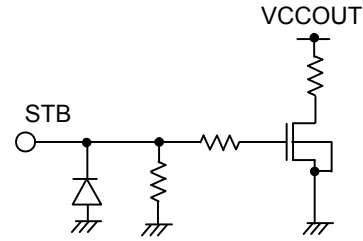

VREF5
(CH5 Standard voltage output)

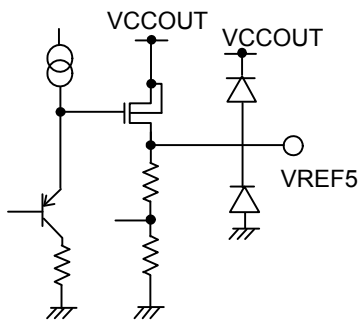

PWM7
(CH7 start signal, LED modulated light signal input)

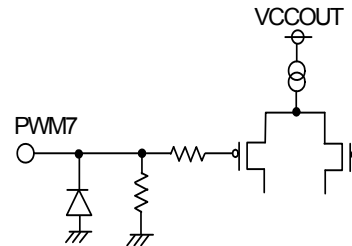

Hx1,2BAT,3,4,VOUT2 (Pch FET source terminal)
 Lx1,21,22,3,4(Nch,Pch FET drain terminal)
 PGND1,2,3,4 (output stage earthing terminal)

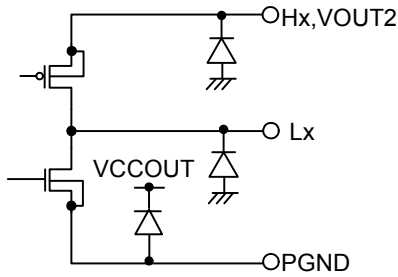

HS6H (PMOS high side SW input terminal)
 HS6L (OMOS high side SW input terminal)

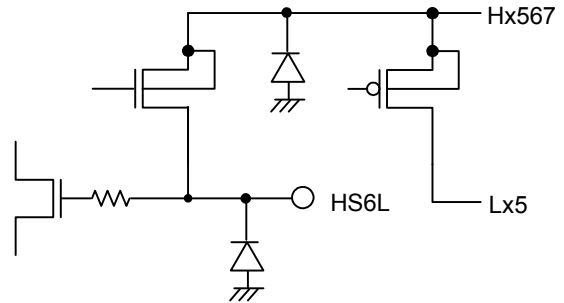

Lx6,7 (Nch FET drain terminal)
 PGND567

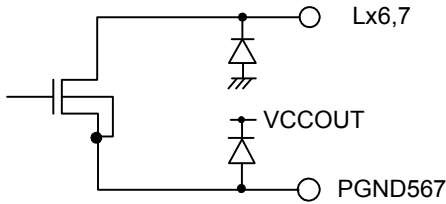

INV7(CH7 Error amplifier's inversion input)
 LED(LED cathode connection terminal)

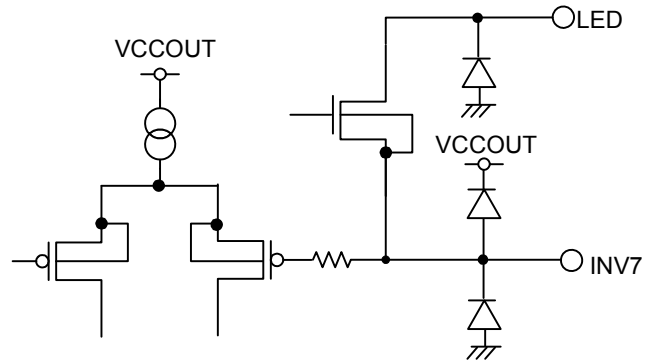

Hx1,2BAT(Pch FET FET source terminal)
 Lx1,21(Nch,Pch FET drain terminal)
 PGND1,2 (output stage earthing terminal)

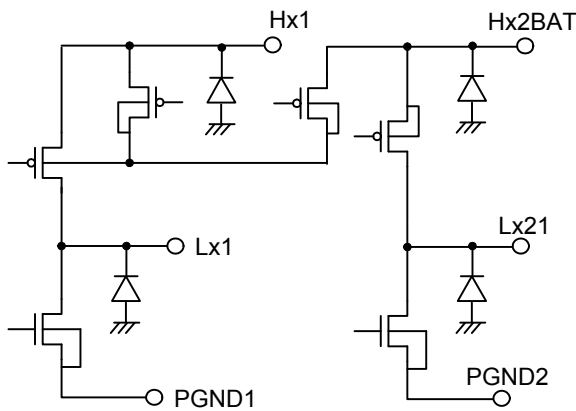

Fig.35 PIN equivalent circuit

●Notes for use

1) Absolute Maximum Ratings

Although the quality of this product has been tightly controlled, deterioration or even destruction may occur if the absolute maximum ratings, such as for applied pressure and operational temperature range, are exceeded. Furthermore, we are unable to assume short or open mode destruction conditions. If special modes which exceed the absolute maximum ratings are expected, physical safety precautions such as fuses should be considered.

2) GND Potential

The potential of the GND pin should be at the minimum potential during all operation status. In addition, please try to do not become electric potential below GND for the terminal other than NON5 including the transient phenomenon in practice. Please do not go down below 0.3V for the NON5 terminal with transient phenomenon and the like when you use.

3) Heat Design

Heat design should consider tolerance dissipation (Pd) during actual use and margins which should be set with plenty of room.

4) Short-circuiting Between Terminals and Incorrect Mounting

When attaching to the printed substrate, pay special attention to the direction and proper placement of the IC. If the IC is attached incorrectly, it may be destroyed. Destruction can also occur when there is a short, which can be caused by foreign objects entering between outputs or an output and the power GND.

5) Operation in Strong Magnetic Fields

Exercise caution when operating in strong magnet fields, as errors can occur.

6) About common impedance

Please do sufficient consideration for the wiring of power source and GND with the measures such as lowering common impedance, making ripple as small as possible (making the wiring as thick and short as possible, dropping ripple from L.C) and the like.

7) Heat Protection Circuit (TSD circuit)

This IC has a built-in Temperature Protection Circuit (TSD circuit). The temperature protection circuit (TSD circuit) is only to cut off the IC from thermal runaway, and has not been designed to protect or guarantee the IC. Therefore, the user should not plan to activate this circuit with continued operation in mind.

8) Rush current at the time of power supply injection.

Because there are times when rush current flows instantaneously in internal logical uncertain state at the time of power source turning on with CMOS IC, please pay attention to the power source coupling capacity, the width of GND pattern wiring and power source, and the reel.

9) IC Terminal Input

This IC is a monolithic IC, and between each element there is a P+ isolation and P substrate for element separation. There is a P-N junction formed between this P-layer and each element's N-layer, which makes up various parasitic elements. For example, when resistance and transistor are connected with a terminal as in fig.35:

○When GND > (terminal A) at the resistance, or GND > (terminal B) at the transistor (NPN), the P-N junction operates as a parasitic diode.

○Also, when GND > (terminal B) at the transistor, a parasitic NPN transistor operates by the N-layer of other elements close to the aforementioned parasitic diode.

With the IC's configuration, the production of parasitic elements by the relationships of the electrical potentials is inevitable. The operation of the parasitic elements can also interfere with the circuit operation, leading to malfunction and even destruction. Therefore, uses which cause the parasitic elements to operate, such as applying voltage to the input terminal which is lower than the GND(P-substrate), should be avoided.

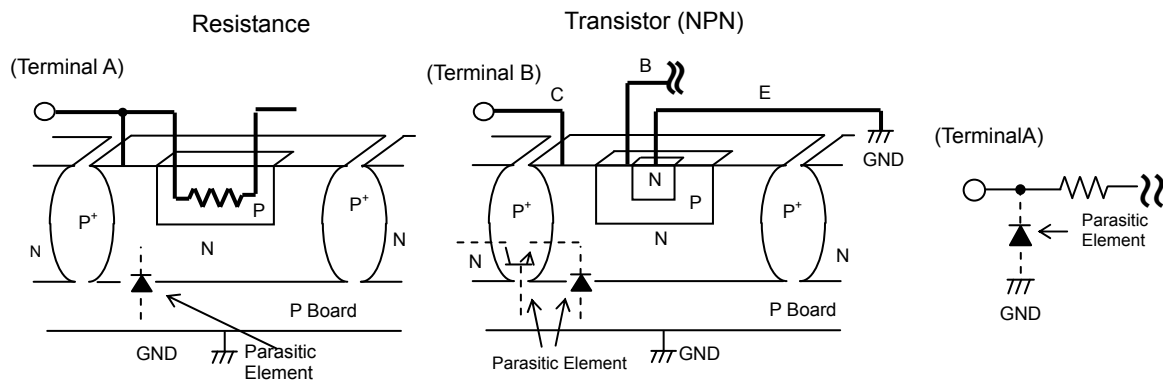

Fig.. 36 Simple Structure of Bipolar IC (Sample)

●Ordering part number

B	D
---	---

Part No.

9	3	5	5
---	---	---	---

Part No.

M	W	V
---	---	---

Package
MWV : UQFN036V5050

E	2
---	---

Packaging and forming specification
E2: Embossed tape and reel

UQFN036V5050

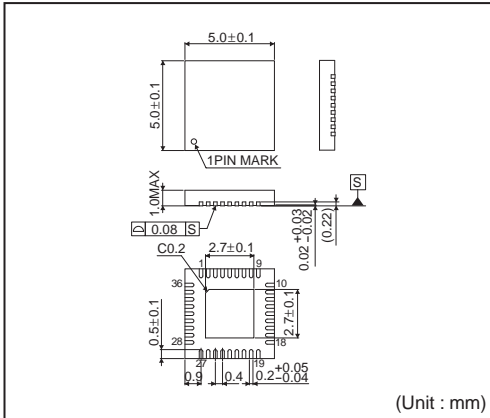

<Tape and Reel information>

Tape	Embossed carrier tape
Quantity	2500pcs
Direction of feed	E2 (The direction is the 1pin of product is at the upper left when you hold reel on the left hand and you pull out the tape on the right hand)

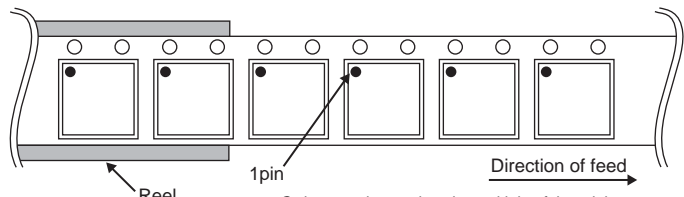

* Order quantity needs to be multiple of the minimum quantity.

Notes

No copying or reproduction of this document, in part or in whole, is permitted without the consent of ROHM Co.,Ltd.

The content specified herein is subject to change for improvement without notice.

The content specified herein is for the purpose of introducing ROHM's products (hereinafter "Products"). If you wish to use any such Product, please be sure to refer to the specifications, which can be obtained from ROHM upon request.

Examples of application circuits, circuit constants and any other information contained herein illustrate the standard usage and operations of the Products. The peripheral conditions must be taken into account when designing circuits for mass production.

Great care was taken in ensuring the accuracy of the information specified in this document. However, should you incur any damage arising from any inaccuracy or misprint of such information, ROHM shall bear no responsibility for such damage.

The technical information specified herein is intended only to show the typical functions of and examples of application circuits for the Products. ROHM does not grant you, explicitly or implicitly, any license to use or exercise intellectual property or other rights held by ROHM and other parties. ROHM shall bear no responsibility whatsoever for any dispute arising from the use of such technical information.

The Products specified in this document are intended to be used with general-use electronic equipment or devices (such as audio visual equipment, office-automation equipment, communication devices, electronic appliances and amusement devices).

The Products specified in this document are not designed to be radiation tolerant.

While ROHM always makes efforts to enhance the quality and reliability of its Products, a Product may fail or malfunction for a variety of reasons.

Please be sure to implement in your equipment using the Products safety measures to guard against the possibility of physical injury, fire or any other damage caused in the event of the failure of any Product, such as derating, redundancy, fire control and fail-safe designs. ROHM shall bear no responsibility whatsoever for your use of any Product outside of the prescribed scope or not in accordance with the instruction manual.

The Products are not designed or manufactured to be used with any equipment, device or system which requires an extremely high level of reliability the failure or malfunction of which may result in a direct threat to human life or create a risk of human injury (such as a medical instrument, transportation equipment, aerospace machinery, nuclear-reactor controller, fuel-controller or other safety device). ROHM shall bear no responsibility in any way for use of any of the Products for the above special purposes. If a Product is intended to be used for any such special purpose, please contact a ROHM sales representative before purchasing.

If you intend to export or ship overseas any Product or technology specified herein that may be controlled under the Foreign Exchange and the Foreign Trade Law, you will be required to obtain a license or permit under the Law.



Thank you for your accessing to ROHM product informations.
More detail product informations and catalogs are available, please contact us.

ROHM Customer Support System

<http://www.rohm.com/contact/>

