

---

# ST-NXP Wireless

## IMPORTANT NOTICE

Dear customer,

As from August 2<sup>nd</sup> 2008, the wireless operations of NXP have moved to a new company, ST-NXP Wireless.

As a result, the following changes are applicable to the attached document.

- **Company name - NXP B.V.** is replaced with **ST-NXP Wireless**.
- **Copyright** - the copyright notice at the bottom of each page “© NXP B.V. 200x. All rights reserved”, shall now read: “© ST-NXP Wireless 200x - All rights reserved”.
- **Web site** - <http://www.nxp.com> is replaced with <http://www.stnwireless.com>
- **Contact information** - the list of sales offices previously obtained by sending an email to [salesaddresses@nxp.com](mailto:salesaddresses@nxp.com) , is now found at <http://www.stnwireless.com> under Contacts.

If you have any questions related to the document, please contact our nearest sales office. Thank you for your cooperation and understanding.

ST-NXP Wireless



# ISP1705

## ULPI Hi-Speed USB transceiver

Rev. 01 — 13 June 2008

Product data sheet

## 1. General description

The ISP1705 is a UTMI+ Low Pin Interface (ULPI) Hi-Speed Universal Serial Bus (USB) transceiver that is fully compliant with *Universal Serial Bus Specification Rev. 2.0*, *On-The-Go Supplement to the USB 2.0 Specification Rev. 1.3* and *UTMI+ Low Pin Interface (ULPI) Specification Rev. 1.1*.

The ISP1705 can transmit and receive USB data at high speed (480 Mbit/s), full speed (12 Mbit/s) and low speed (1.5 Mbit/s), and provides a pin-optimized, physical layer front-end attachment to the USB host, peripheral or OTG controller with Single Data Rate (SDR) or Dual Data Rate (DDR) ULPI link. The ISP1705 can transparently transmit and receive UART signaling.

It is ideal for use in portable electronic devices, such as mobile phones, digital still cameras, digital video cameras, Personal Digital Assistants (PDAs) and digital audio players. It allows USB Application-Specific Integrated Circuits (ASICs), Programmable Logic Devices (PLDs) or any system chip set to interface with the physical layer of the USB through an 8-pin (DDR) or 12-pin (SDR) interface.

The ISP1705 can interface to devices with digital I/O voltages in the range of 3.0 V to 3.6 V.

The ISP1705 is available in HVQFN36 and TFBGA36 packages.

## 2. Features

- Fully complies with:
  - ◆ USB: *Universal Serial Bus Specification Rev. 2.0*
  - ◆ OTG: *On-The-Go Supplement to the USB 2.0 Specification Rev. 1.3*
  - ◆ ULPI: *UTMI+ Low Pin Interface (ULPI) Specification Rev. 1.1*
- Interfaces to USB host, peripheral or OTG cores; optimized for portable devices or system ASICs with built-in ULPI link
- Complete Hi-Speed USB physical front-end solution that supports high speed (480 Mbit/s), full speed (12 Mbit/s) and low speed (1.5 Mbit/s)
  - ◆ Integrated  $45\ \Omega \pm 10\%$  high-speed termination resistors,  $1.5\ \text{k}\Omega \pm 5\%$  full-speed device pull-up resistor, and  $15\ \text{k}\Omega \pm 5\%$  host termination resistors
  - ◆ Integrated parallel-to-serial and serial-to-parallel converters to transmit and receive
  - ◆ USB clock and data recovery to receive USB data up to  $\pm 500$  ppm
  - ◆ Insertion of stuff bits during transmit and discarding of stuff bits during receive
  - ◆ Non-Return-to-Zero Inverted (NRZI) encoding and decoding
  - ◆ Supports bus reset, suspend, resume and high-speed detection handshake (chirp)

- Complete USB OTG physical front-end that supports Host Negotiation Protocol (HNP) and Session Request Protocol (SRP)
  - ◆ Supports external charge pump or external  $V_{BUS}$  power switch
  - ◆ Complete control over USB termination resistors
  - ◆ Data line and  $V_{BUS}$  pulsing session request methods
  - ◆ Integrated  $V_{BUS}$  voltage comparators
  - ◆ Integrated cable (ID) detector
- Flexible system integration and very low power consumption, optimized for portable devices
  - ◆ 3.0 V to 4.5 V supply voltage input range
  - ◆ Internal voltage regulator supplies 2.7 V or 3.3 V and 1.8 V
  - ◆ Supports interfacing I/O voltage of 3.0 V to 3.6 V; separate I/O voltage supply pins minimize crosstalk
  - ◆ Power down internal regulators in Power-down mode when  $V_{CC(I/O)}$  is not present or when the chip is not selected
  - ◆ Typical operating current of 13 mA to 32 mA, depending on the USB speed and bus utilization
  - ◆ Typical current consumption  $I_{CC}$  is 70  $\mu$ A in suspend mode and 0.5  $\mu$ A in Power-down mode
  - ◆ 3-state ULPI interface by the CHIP\_SEL or CHIP\_SEL\_N pin, allowing bus reuse by other applications
- Highly optimized ULPI compliant
  - ◆ 60 MHz, 8-pin or 12-pin interface between the core and the transceiver, including a 4-bit DDR bus or an 8-bit SDR bus
  - ◆ DDR or SDR interface selectable by pin
  - ◆ Supports 60 MHz output clock configuration
  - ◆ Integrated Phase-Locked Loop (PLL) supporting input clock frequencies of 13 MHz, 19.2 MHz, 24 MHz or 26 MHz
  - ◆ Crystal or clock frequency selectable by pin
  - ◆ Fully programmable ULPI-compliant register set
  - ◆ 3-pin or 6-pin full-speed or low-speed serial mode
  - ◆ Internal Power-On Reset (POR) circuit
- UART interface:
  - ◆ Supports transparent UART signaling on DP and DM pins for the UART accessory application
  - ◆ 2.7 V UART signaling on DP and DM pins
  - ◆ Entering UART mode by register setting
  - ◆ Exiting UART mode by asserting STP or by toggling the CHIP\_SEL or CHIP\_SEL\_N pin
- Full industrial grade operating temperature range from  $-40\text{ }^{\circ}\text{C}$  to  $+85\text{ }^{\circ}\text{C}$
- ESD compliance:
  - ◆ JESD22-A114D 2 kV contact Human Body Model (HBM)
  - ◆ JESD22-A115-A 200 V Machine Model (MM)
  - ◆ JESD22-C101-C 500 V Charged Device Model (CDM)
  - ◆ IEC 61000-4-2 8 kV contact on the DP and DM pins

- Available in small HVQFN36 and TFBGA36 Restriction of Hazardous Substances (RoHS) compliant, halogen-free and lead-free packages

### 3. Applications

- Digital still camera
- Digital TV
- Digital Video Disc (DVD) recorder
- External storage device, for example:
  - ◆ Magneto-Optical (MO) drive
  - ◆ Optical drive (CD-ROM, CD-RW, CD-DVD)
  - ◆ Zip drive
- Mobile phone
- MP3 player
- PDA
- Printer
- Scanner
- Set-Top Box (STB)
- Video camera

### 4. Ordering information

Table 1. Ordering information

Type number	Package		
	Name	Description	Version
ISP1705HN	HVQFN36	plastic thermal enhanced very thin quad flat package; no leads; 36 terminals; body 5 × 5 × 0.85 mm	SOT818-1
ISP1705AET	TFBGA36	plastic thin fine-pitch ball grid array package; 36 balls; body 3.5 × 3.5 × 0.8 mm	SOT912-1

### 5. Marking

Table 2. Marking codes

Type number	Marking code <sup>[1]</sup>
ISP1705HN	1705
ISP1705AET	705A

[1] The package marking is the first line of text on the IC package and can be used for IC identification.

6. Block diagram

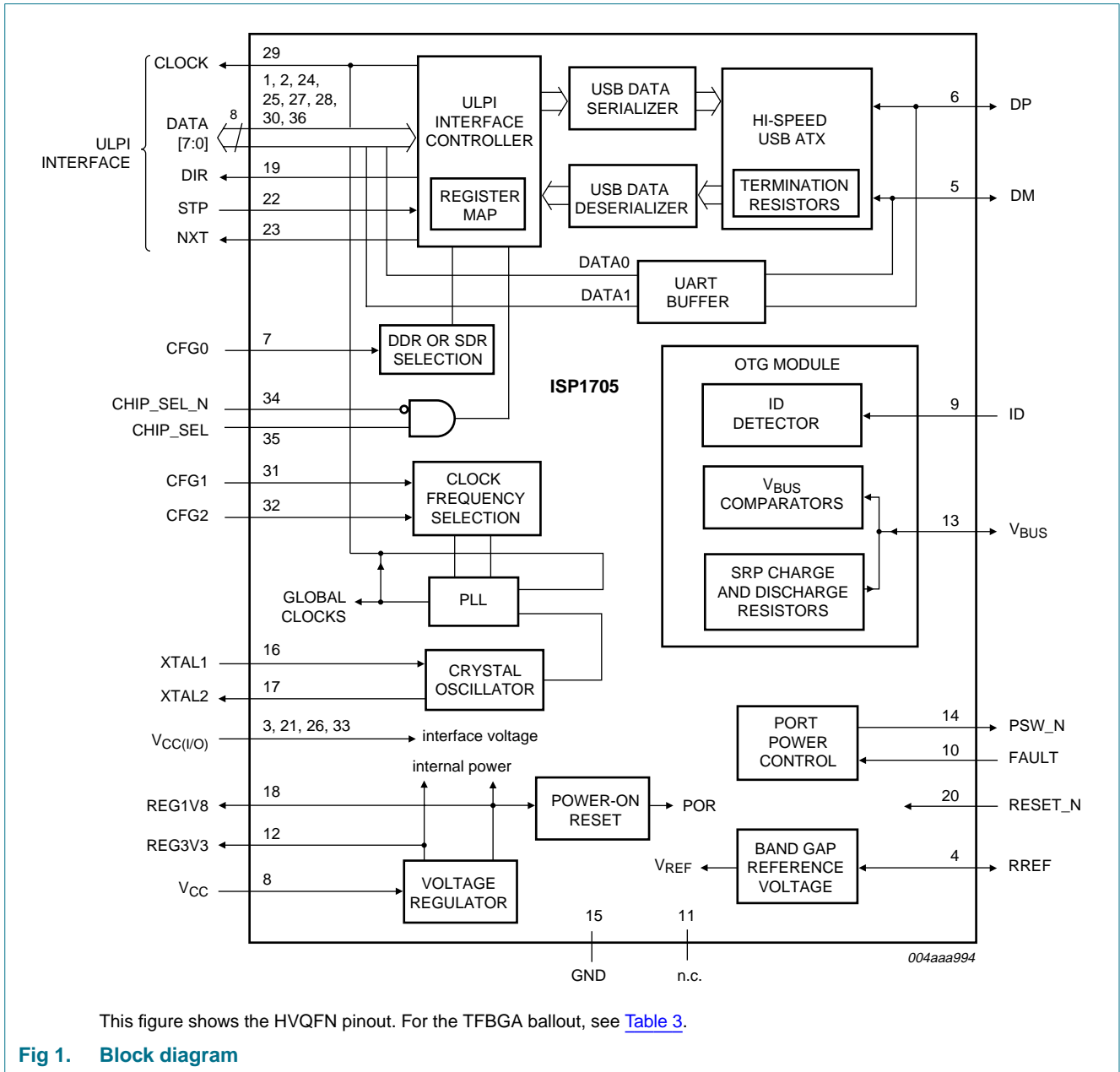

This figure shows the HVQFN pinout. For the TFBGA ballout, see [Table 3](#).

Fig 1. Block diagram

## 7. Pinning information

### 7.1 Pinning

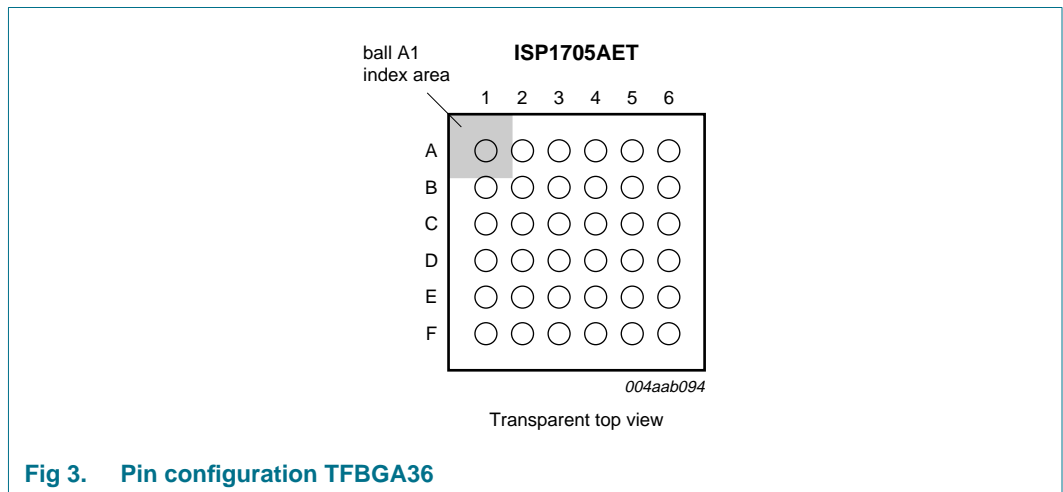
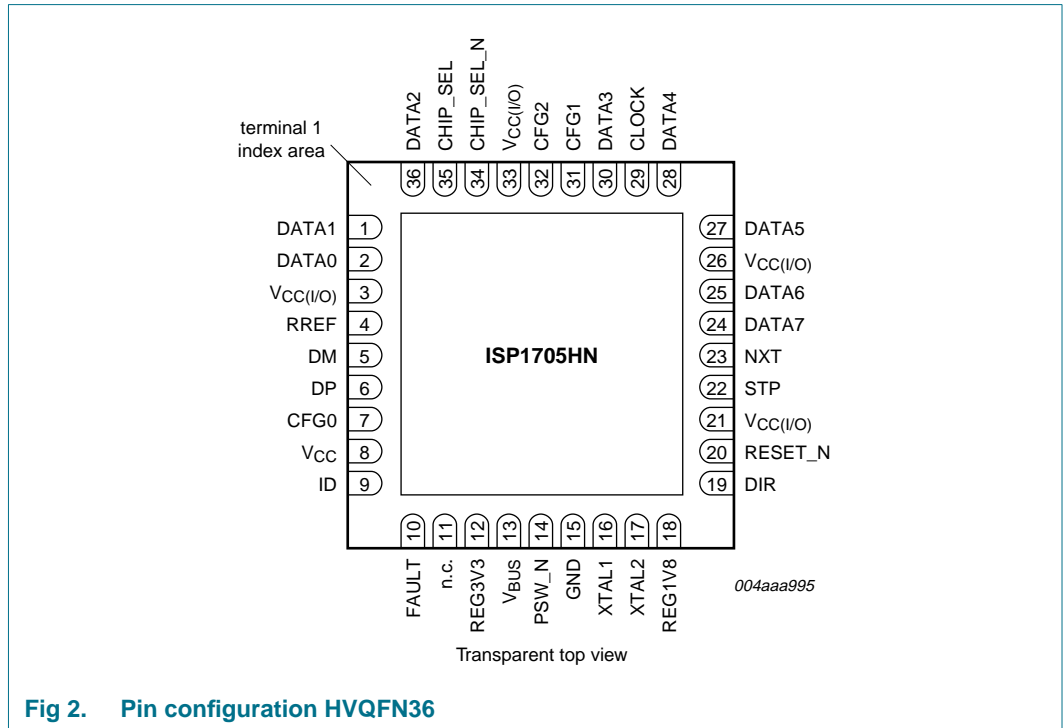

## 7.2 Pin description

Table 3. Pin description

Symbol <sup>[1]</sup>	Pin		Type <sup>[2]</sup>	Description <sup>[3]</sup>
	HVQFN36 (ISP1705HN)	TFBGA36 (ISP1705AET)		
DATA1	1	A1	I/O	ULPI data pin 1 3-state output; plain input
DATA0	2	B1	I/O	ULPI data pin 0 3-state output; plain input
V <sub>CC(I/O)</sub>	3	B2	P	input I/O supply voltage; 3.0 V to 3.6 V; a 0.1 μF decoupling capacitor is recommended
RREF	4	C2	AI/O	resistor reference; connect through a 12 kΩ ± 1 % resistor to GND
DM	5	C1	AI/O	connect to the D– pin of the USB connector <ul style="list-style-type: none"> <li>• USB mode: D– input or output</li> <li>• UART mode: TXD output</li> </ul>
DP	6	D1	AI/O	connect to the D+ pin of the USB connector <ul style="list-style-type: none"> <li>• USB mode: D+ input or output</li> <li>• UART mode: RXD input</li> </ul> <p>During UART mode, an internal 125 kΩ ± 20 % pull-up resistor is present on this pin.</p>
CFG0	7	E1	I	select SDR or DDR ULPI interface: <ul style="list-style-type: none"> <li>• SDR: connect this pin to GND</li> <li>• DDR: connect this pin to REG3V3</li> </ul> <p>plain input; TTL</p>
V <sub>CC</sub>	8	F3	P	input supply voltage or battery source; 3.0 V to 4.5 V <b>Remark:</b> Below 3.0 V, USB full-speed and low-speed transactions are not guaranteed to work, though some devices may work with the ISP1705 at these voltages.
ID	9	D3	I	identification (ID) pin of the micro-USB connector; if this pin is not in use, connect it directly to the REG3V3 pin (an internal 400 kΩ pull-up resistor is present on this pin) plain input; TTL
FAULT	10	E2	I	input for the V <sub>BUS</sub> digital overcurrent or fault detector signal; if this pin is not in use, connect it to GND plain input, 5 V tolerant
n.c.	11	F1, F2	-	not connected
REG3V3	12	E3	P	3.3 V regulator output for USB mode or 2.7 V regulator output for UART mode; requires parallel 0.1 μF and 4.7 μF capacitors; internally powers ATX and other analog circuits; must not be used to power external circuits
V <sub>BUS</sub>	13	F4	AI/O	connect to the V <sub>BUS</sub> pin of the USB connector; if this pin is not in use, leave it open (R <sub>I(idle)(VBUS)</sub> is present on this pin)
PSW_N	14	D4	OD	active-LOW external V <sub>BUS</sub> power switch or external charge pump enable open-drain output, 4 mA current sinking capability, 5 V tolerant
GND	15	C5, D2, E4	-	ground

Table 3. Pin description ...continued

Symbol <sup>[1]</sup>	Pin		Type <sup>[2]</sup>	Description <sup>[3]</sup>
	HVQFN36 (ISP1705HN)	TFBGA36 (ISP1705AET)		
XTAL1	16	F5	AI/O	crystal oscillator or clock input; 1.8 V peak input allowed; frequency depends on status on the CFG1 pin
XTAL2	17	F6	AI/O	crystal oscillator output; when a crystal oscillator is used, leave this pin open
REG1V8	18	E6	P	1.8 V regulator output; requires parallel 0.1 $\mu$ F and 4.7 $\mu$ F capacitors; internally powers the digital core; must not be used to power external circuits
DIR	19	E5	O	ULPI direction signal 3-state output
RESET_N	20	C4	I	active-LOW, asynchronous reset input plain input
V <sub>CC(I/O)</sub>	21	B5	P	input I/O supply voltage; 3.0 V to 3.6 V; a 0.1 $\mu$ F decoupling capacitor is recommended
STP	22	D6	I	ULPI stop signal plain input
NXT	23	D5	O	ULPI next signal 3-state output
DATA7	24	C6	I/O	ULPI data pin 7 3-state output; plain input
DATA6	25	B6	I/O	ULPI data pin 6 3-state output; plain input
V <sub>CC(I/O)</sub>	26	-	P	input I/O supply voltage; 3.0 V to 3.6 V; a 0.1 $\mu$ F decoupling capacitor is recommended
DATA5	27	A6	I/O	ULPI data pin 5 3-state output; plain input
DATA4	28	A5	I/O	ULPI data pin 4 3-state output; plain input
CLOCK	29	A4	O	60 MHz clock output when crystal is attached or clock is applied on the XTAL1 pin 3-state output
DATA3	30	A3	I/O	ULPI data pin 3 3-state output; plain input
CFG1	31	B4	I	select crystal or clock frequency with CFG2; see <a href="#">Table 6</a> plain input
CFG2	32	B3	I	select crystal or clock frequency with CFG1; see <a href="#">Table 6</a> plain input
V <sub>CC(I/O)</sub>	33	-	P	input I/O supply voltage; 3.0 V to 3.6 V; a 0.1 $\mu$ F decoupling capacitor is recommended
CHIP_SEL_N	34	C3	I	active-LOW chip select input; when this pin is not in use, connect it to GND plain input



Table 3. Pin description ...continued

Symbol <sup>[1]</sup>	Pin		Type <sup>[2]</sup>	Description <sup>[3]</sup>
	HVQFN36 (ISP1705HN)	TFBGA36 (ISP1705AET)		
CHIP_SEL	35	-	I	active-HIGH chip select input; when this pin is not in use, connect it to $V_{CC(I/O)}$ plain input
DATA2	36	A2	I/O	ULPI data pin 2 3-state output; plain input
GND	exposed die pad	-	P	ground

[1] Symbol names ending with underscore N (for example, NAME\_N) indicate active-LOW signals.

[2] I = input; O = output; I/O = digital input/output; OD = open-drain output; A/I/O = analog input/output; P = power supply or ground pin.

[3] A detailed description of these pins can be found in [Section 8.12](#).

## 8. Functional description

### 8.1 ULPI interface controller

The ISP1705 provides a 12-pin interface that is compliant with *UTMI+ Low Pin Interface (ULPI) Specification Rev. 1.1*. This interface must be connected to a USB link.

The ULPI interface controller provides the following functions:

- ULPI-compliant interface and register set
- Allows full control over the USB peripheral or host functionality
- Parses the USB transmit and receive data
- Prioritizes the USB receive data, USB transmit data, interrupts and register operations
- Low-power mode
- Transparent UART mode
- 3-pin serial mode
- 6-pin serial mode
- Generates RXCMDs (status updates)
- Maskable interrupts

For more information on the ULPI protocol, see [Section 10](#).

### 8.2 USB serializer and deserializer

The USB data serializer prepares data to transmit on the USB bus. To transmit data, the USB link sends a transmit command and data on the ULPI bus. The serializer performs parallel-to-serial conversion, bit stuffing and NRZI encoding. For packets with a PID, the serializer adds a SYNC pattern to the start of the packet, and an EOP pattern to the end of the packet. When the serializer is busy and cannot accept any more data, the ULPI interface controller deasserts NXT.

The USB data deserializer decodes data received from the USB bus. When data is received, the deserializer strips the SYNC and EOP patterns, and then performs serial-to-parallel conversion, NRZI decoding and discarding of stuff bits on the data payload. The ULPI interface controller sends data to the USB link by asserting DIR, and then asserting NXT whenever a byte is ready. The deserializer also detects various receive errors, including bit stuff errors, elasticity buffer underrun or overrun, and byte-alignment errors.

### 8.3 Hi-Speed USB (USB 2.0) ATX

The Hi-Speed USB ATX block is an analog front-end containing the circuitry needed to transmit, receive and terminate the USB bus in high speed, full speed and low speed, for USB peripheral, host or OTG implementations. The following circuitry is included:

- Differential drivers to transmit data at high speed, full speed and low speed
- Differential and single-ended receivers to receive data at high speed, full speed and low speed
- Squelch circuit to detect high-speed bus activity

- High-speed disconnect detector
- 45  $\Omega$  high-speed bus terminations on pins DP and DM
- 1.5 k $\Omega$  pull-up resistor on pin DP
- 15 k $\Omega$  bus terminations on pins DP and DM

For details on controlling resistor settings, see [Table 15](#).

## 8.4 Voltage regulator

The ISP1705 contains a built-in voltage regulator that conditions the  $V_{CC}$  supply for use inside the ISP1705. The voltage regulator:

- Supports input supply range  $3.0\text{ V} < V_{CC} < 4.5\text{ V}$ .
- Can be supplied from a battery with the voltage range mentioned above.
- Supplies internal digital circuitry with 1.8 V and analog circuitry with 3.3 V or 2.7 V.
- In USB mode, automatically bypasses the internal 3.3 V regulator when  $V_{CC} < 3.5\text{ V}$ : the internal analog circuitry directly draws power from the  $V_{CC}$  pin. In UART mode, the bypass switch will be disabled.
- Will be shut down when  $V_{CC(I/O)}$  is not present or when chip select is deasserted.

## 8.5 Crystal oscillator and PLL

The ISP1705 has a built-in crystal oscillator and a Phase-Locked Loop (PLL) for clock generation. When a crystal is in use, the built-in crystal oscillator generates a square wave clock for internal use. A square wave clock of the same frequency can also be driven directly into the XTAL1 pin. Using an existing square wave clock can save the cost of a crystal and also reduce the board space. The crystal or clock frequencies supported are 13 MHz, 19.2 MHz, 24 MHz and 26 MHz.

The PLL takes the square wave clock from the crystal oscillator and multiplies or divides it into various frequencies for internal use.

The PLL produces the following frequencies, irrespective of the clock source:

- 1.5 MHz for low-speed USB data
- 12 MHz for full-speed USB data
- 60 MHz clock for the ULPI interface controller
- 480 MHz for high-speed USB data
- Other internal frequencies for data conversion and data recovery

## 8.6 UART buffer

The UART buffer includes circuits to support the transparent UART signaling between the DATA0 or DATA1 pin and the DM or DP pin.

When the ISP1705 is put into UART mode, it acts as a voltage level shifter between the following pins:

- From DATA0 ( $V_{CC(I/O)}$  level) to DM (2.7 V level) for the UART TXD signaling path.
- From DP (2.7 V level) to DATA1 ( $V_{CC(I/O)}$  level) for the UART RXD signaling path.

## 8.7 OTG module

This module contains several sub-blocks that provide all the functionality required by the USB OTG specification. Specifically, it provides the following circuits:

- The ID detector to sense the ID pin of the micro-USB cable. The ID pin dictates which device is initially configured as a host and which as a peripheral.
- $V_{BUS}$  comparators to determine the  $V_{BUS}$  voltage level. This is required for the  $V_{BUS}$  detection, SRP and HNP.
- Resistors to temporarily charge and discharge  $V_{BUS}$ . This is required for SRP.

### 8.7.1 ID detector

The ID detector detects which end of the micro-USB cable is plugged in. The ID detector must first be enabled by setting the ID\_PULLUP register bit to logic 1. If the ISP1705 senses a state of the ID pin that is different from the previously reported state, an RXCMD status update will be sent to the USB link, or an interrupt will be asserted.

- If the micro-B end of the cable is plugged in (or nothing is plugged in), the ISP1705 will report that ID\_GND is logic 1. The USB link must be in the B-device state.
- If the micro-A end of the cable is plugged in, the ISP1705 will report that ID\_GND is logic 0. The USB link must be in the A-device state.

The ID pin has a weak pull-up resistor ( $R_{\text{weakPU(ID)}}$ ) permanently enabled to avoid the floating condition.

### 8.7.2 $V_{BUS}$ comparators

The ISP1705 provides three comparators to detect the  $V_{BUS}$  voltage level. The comparators are explained in the following subsections.

#### 8.7.2.1 $V_{BUS}$ valid comparator

This comparator is used by hosts and A-devices to determine whether the voltage on  $V_{BUS}$  is at a valid level for operation. The ISP1705 minimum threshold for the  $V_{BUS}$  valid comparator is 4.4 V. Any voltage on  $V_{BUS}$  below this threshold is considered invalid. During power-up, it is expected that the comparator output will be ignored.

#### 8.7.2.2 Session valid comparator

The session valid comparator is a TTL-level input that determines when  $V_{BUS}$  is high enough for a session to start. Peripherals, A-devices and B-devices use this comparator to detect when a session is started. The A-device also uses this comparator to determine when a session is completed. The session valid threshold of the ISP1705 is between 0.8 V to 2.0 V.

#### 8.7.2.3 Session end comparator

The session end comparator determines when  $V_{BUS}$  is below the B-device session end threshold of 0.2 V to 0.8 V. The B-device uses this threshold to determine when a session has ended.

### 8.7.3 SRP charge and discharge resistors

The ISP1705 provides on-chip resistors for short-term charging and discharging of  $V_{BUS}$ . These are used by the B-device to request a session, prompting the A-device to restore the  $V_{BUS}$  voltage. First, the B-device makes sure that  $V_{BUS}$  is fully discharged from the previous session by setting the DISCHRG\_VBUS register bit to logic 1 and waiting for SESS\_END to be logic 1. Then the B-device charges  $V_{BUS}$  by setting the CHRG\_VBUS register bit to logic 1. The A-device sees that  $V_{BUS}$  is charged above the session valid threshold and starts a session by turning on the  $V_{BUS}$  voltage.

### 8.8 Port power control

For an OTG or host application, the ISP1705 uses the PSW\_N pin to control the external power switch for the  $V_{BUS}$  5 V supply. The overcurrent detector output of the external power switch can be connected to the FAULT pin of the ISP1705 to indicate to the ULPI link the  $V_{BUS}$  overcurrent status. For the connection scheme, see [Figure 4](#).

When the FAULT pin is not used, connect it to GND.

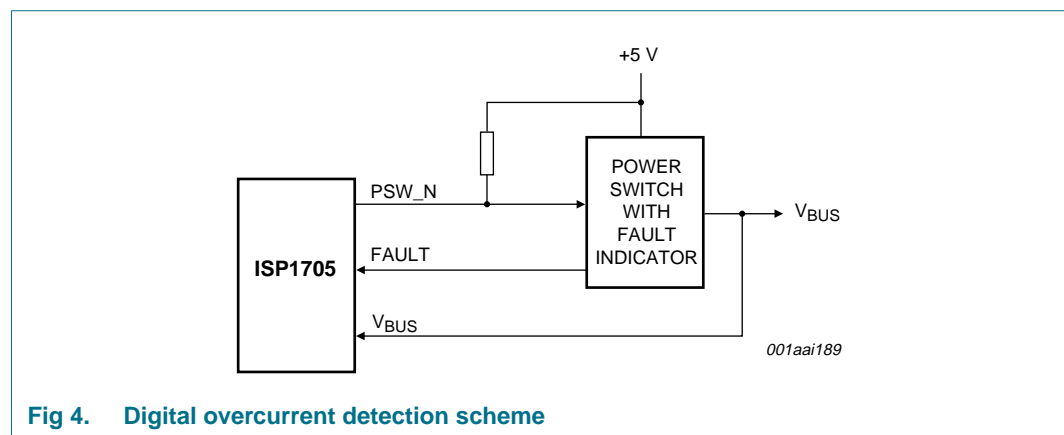

Fig 4. Digital overcurrent detection scheme

### 8.9 Band gap reference voltage

The band gap circuit provides a stable internal voltage reference to bias the analog circuitry. This band gap circuit requires an accurate external reference resistor. Connect a  $12\text{ k}\Omega \pm 1\%$  resistor between the RREF pin and GND.

### 8.10 Power-On Reset (POR)

An internal POR pulse is generated when REG1V8 rises above  $V_{POR(trip)}$ . The internal POR pulse will be generated whenever REG1V8 drops below  $V_{POR(trip)}$  for more than  $t_{w(REG1V8\_L)}$ .

To give a better view of the functionality, [Figure 5](#) shows a possible curve of REG1V8. The internal POR starts with logic 0 at  $t_0$ . At  $t_1$ , the detector will see the passing of the trip level so that a POR pulse is generated to reset all internal circuits. If REG1V8 dips from  $t_2$  to  $t_3$  for greater than  $t_{w(REG1V8\_L)}$ , another POR pulse is generated. If the dip from  $t_4$  to  $t_5$  is less than  $t_{w(REG1V8\_L)}$ , the internal POR pulse will not be generated and will remain LOW.

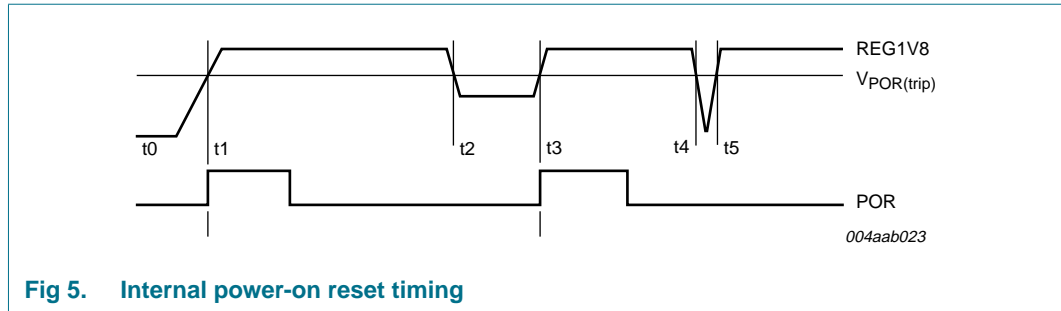

Fig 5. Internal power-on reset timing

### 8.11 Power-up, reset and bus idle sequence

[Figure 6](#) shows a typical start-up sequence.

On power-up, the ISP1705 performs an internal power-on reset and asserts DIR to indicate to the link that the ULPI bus cannot be used. When the internal PLL is stable, the ISP1705 deasserts DIR and drives a 60 MHz clock on the CLOCK pin. The power-up time depends on the  $V_{CC}$  supply rise time, the crystal start-up time, and the PLL start-up time  $t_{startup(PLL)}$ . When DIR is deasserted, the link must drive the data bus to a valid level. By default, the link must drive data to LOW. Before beginning USB packets, the link must set the RESET bit in the FUNC\_CTRL register (see [Section 11.5](#)) to reset the ISP1705. After the RESET bit is set, the ISP1705 will assert DIR until the internal reset completes. The ISP1705 will automatically deassert DIR and clear the RESET bit when the reset has completed. After every reset, an RXCMD is sent to the link to update USB status information. After this sequence, the ULPI bus is ready for use and the link can start USB operations.

If chip select is non-active, the ISP1705 will be kept in Power-down mode. In Power-down mode, all ULPI interface pins will be put in 3-state, the internal regulator will be shut down, and the total current consumption in Power-down mode will be less than that in low-power mode.

The link can do a hardware reset to the ISP1705 by toggling chip select. The recommended sequence is:

1. De-activate chip select.
2. Wait for at least  $t_{PWRDN}$ .
3. Activate chip select.

If the low-power mode is entered when  $V_{CC(I/O)}$  is lost, see [Table 9](#).

The recommended power-up sequence for the link is:

1. Apply the  $V_{CC}$  and  $V_{CC(I/O)}$  voltage.
2. Activate chip select.
3. The link waits for at least  $t_{PWRUP}$ , ignoring all the ULPI pin statuses.
4. The link may start to detect the DIR status level. If DIR is detected LOW, the link may send a RESET command.

The ULPI interface is ready for use.

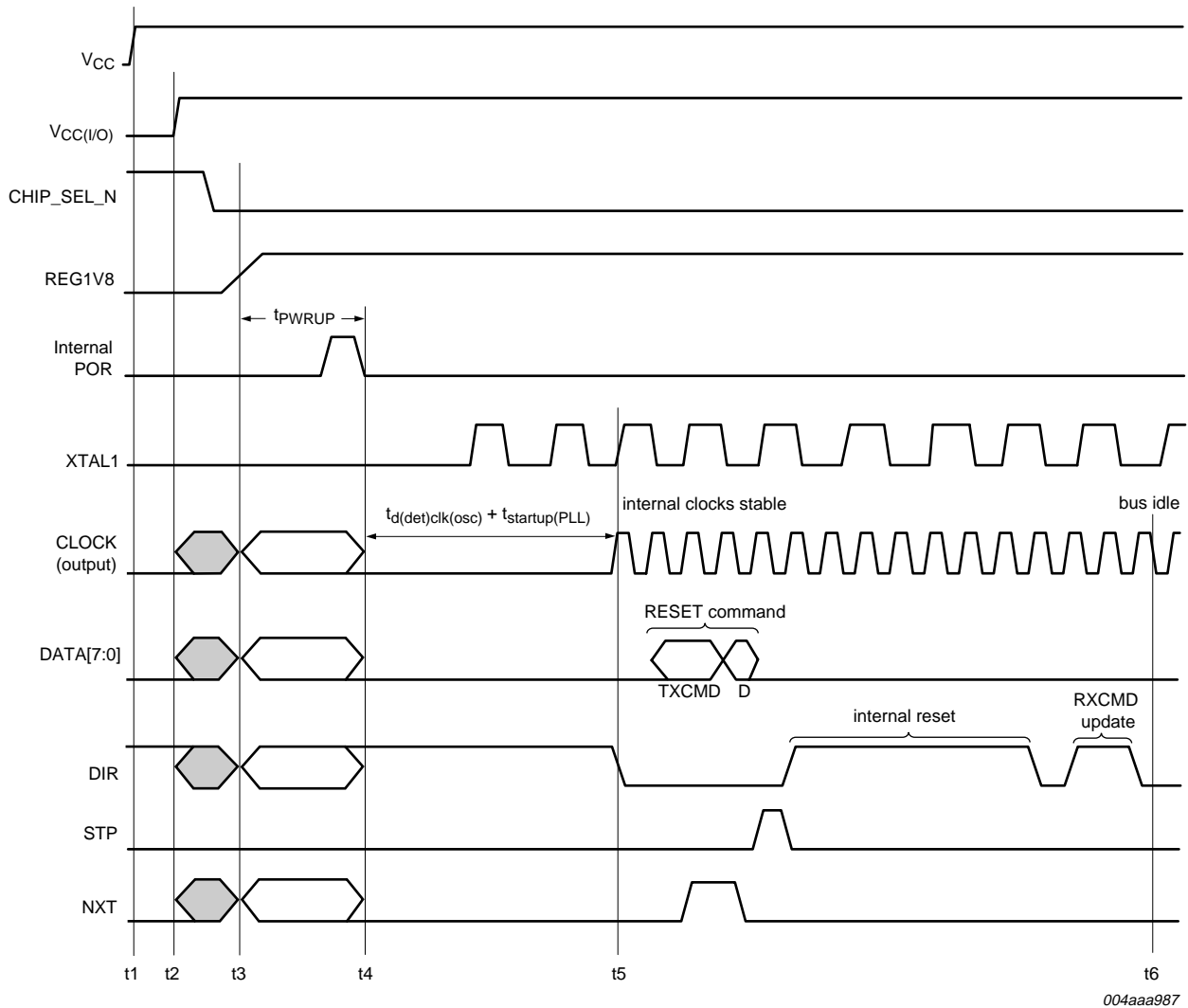

t1 = V<sub>CC</sub> is applied to the ISP1705.

t2 = V<sub>CC(I/O)</sub> is turned on. ULPI interface pins CLOCK, DATA[7:0], DIR and NXT are in 3-state as long as chip select is non-active.

t3 = Chip select turns from non-active to active. The ISP1705 regulator starts to turn on. ULPI pads are not in 3-state and may drive to either LOW or HIGH. It is recommended that the link ignores ULPI pins status during t<sub>PWRUP</sub>.

t4 = Power-on reset threshold is reached and the POR pulse is generated. After the POR pulse, ULPI pins are driven to a defined level. DIR is driven to HIGH and the other pins are driven to LOW.

t5 = The PLL is stabilized after t<sub>d(det)clk(osc) + t<sub>startup(PLL)</sub>. The CLOCK pin starts to output 60 MHz. The DIR pin will transition from HIGH to LOW. The link must drive DATA[7:0] and STP to LOW as the idle state. The link will then issue a reset command to initialize the ISP1705.</sub>

t6 = The power-up sequence is completed and the ULPI bus interface is ready for use.

**Fig 6. Power-up and reset sequence required before the ULPI bus is ready for use**

**8.11.1 Interface protection**

By default, the ISP1705 enables a weak pull-up resistor on STP. If the STP pin is unexpectedly HIGH at any time, the ISP1705 will protect the ULPI interface by enabling weak pull-down resistors on DATA[7:0].

The interface protect feature prevents unwanted activity of the ISP1705 whenever the ULPI interface is not correctly driven by the link. For example, when the link powers up more slowly than the ISP1705.

The interface protect feature can be disabled by setting the INTF\_PROT\_DIS bit to logic 1.

**8.11.2 Interface behavior with respect to RESET\_N**

The use of the RESET\_N pin is optional. When RESET\_N is asserted (LOW), all logic in the ISP1705 will be reset, including the analog circuitry and ULPI registers. During reset, the link must drive DATA[7:0] and STP to LOW; otherwise undefined behavior may result. When RESET\_N is deasserted (HIGH), 60 MHz clock will start. [Figure 7](#) shows the ULPI interface behavior when RESET\_N is asserted (LOW), and subsequently deasserted (HIGH). The behavior of [Figure 7](#) applies only when chip select is asserted. If RESET\_N is not used, it must be connected to V<sub>CC(I/O)</sub>.

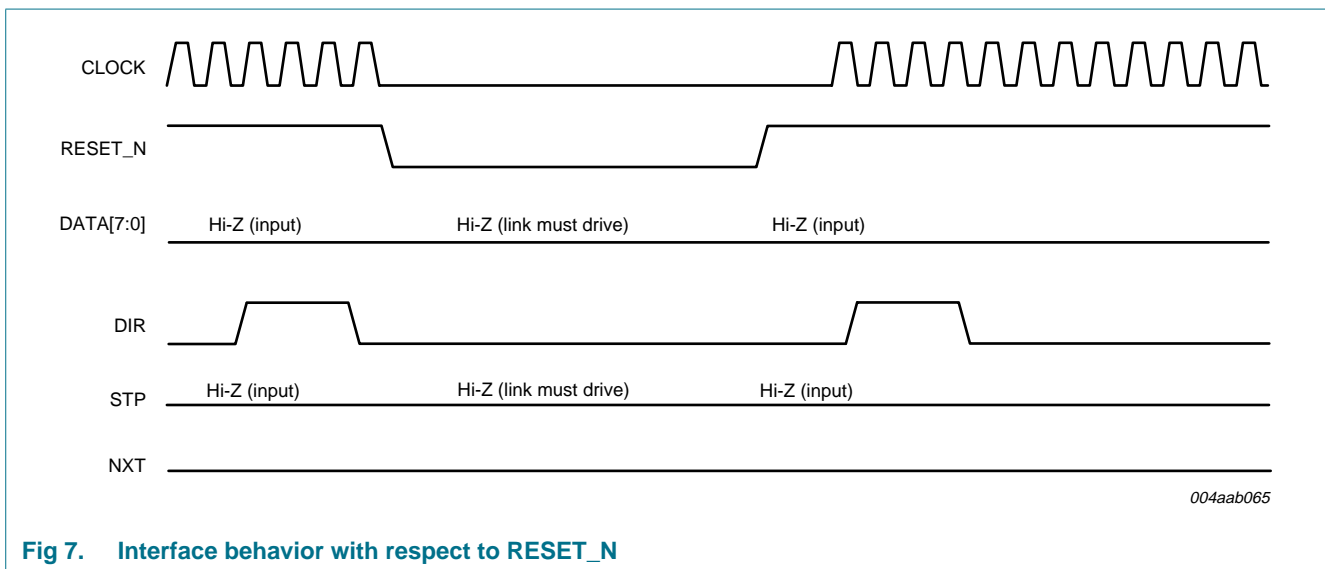

**Fig 7. Interface behavior with respect to RESET\_N**

**8.11.3 Interface behavior with respect to chip select**

The use of chip select as a power-down control signal is optional. When chip select is deasserted, the ISP1705 will 3-state ULPI pins and power-down the internal circuitry. If chip select is not used as a power-down control signal, CHIP\_SEL\_N must be connected to LOW. [Figure 8](#) shows the ULPI interface behavior when chip select is asserted and subsequently deasserted.



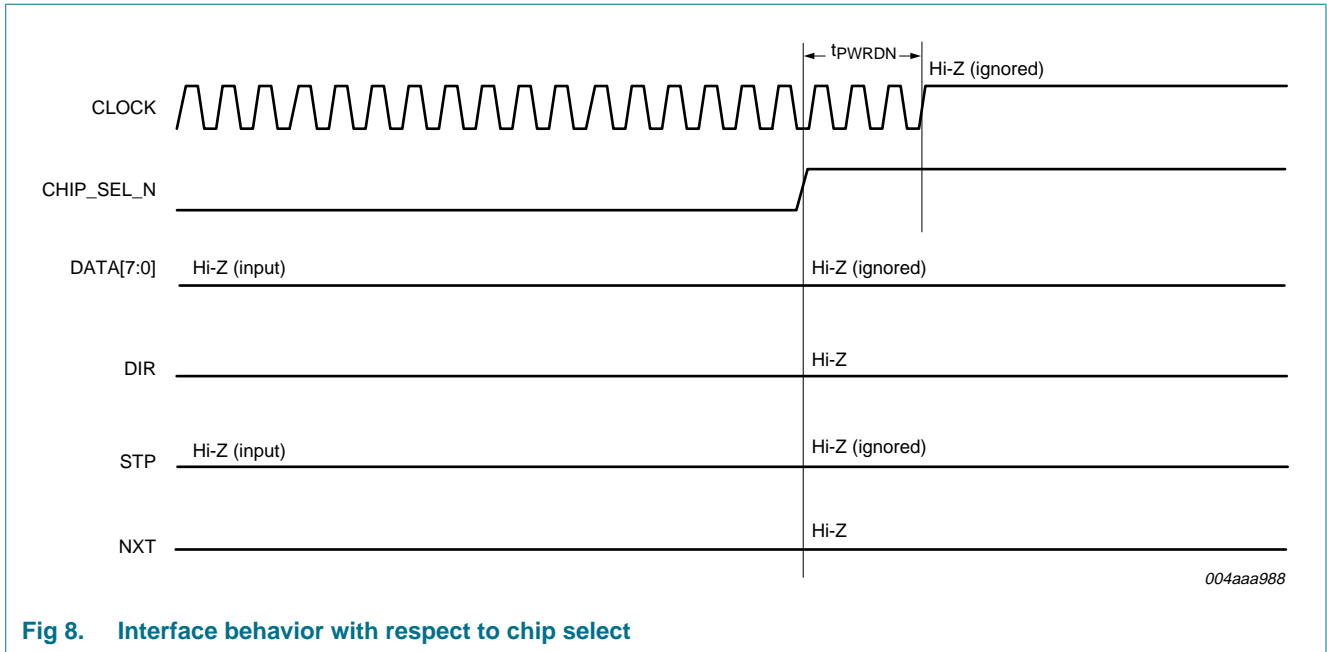

Fig 8. Interface behavior with respect to chip select

## 8.12 Detailed description of pins

### 8.12.1 DATA[7:0]

Bidirectional data bus pins. The USB link must drive DATA[7:0] to LOW when the ULPI bus is idle. When the link has data to transmit to the PHY, it drives a nonzero value. Weak pull-down resistors are incorporated into DATA[7:0] pins as part of the interface protect feature. For details, see [Section 8.11.1](#).

DATA[7:0] pins can also be 3-stated when chip select is deasserted.

These pins can be reconfigured to carry various data types when the chip is not in synchronous mode. For details, see [Section 9.2](#).

### 8.12.2 $V_{CC(I/O)}$

The input supply power pin that sets the I/O voltage level. A 0.1  $\mu$ F decoupling capacitor is recommended on each  $V_{CC(I/O)}$  pin.  $V_{CC(I/O)}$  powers the on-chip pads of the following pins:

- CFG1
- CFG2
- CHIP\_SEL
- CHIP\_SEL\_N
- CLOCK
- DATA[7:0]
- DIR
- NXT
- STP
- RESET\_N

### 8.12.3 RREF

Resistor reference analog I/O pin. A  $12\text{ k}\Omega \pm 1\%$  resistor must be connected between the RREF pin and GND. This provides an accurate voltage reference that biases internal analog circuitry. Less accurate resistors cannot be used. It will affect the biasing current for analog circuits, thus the USB signal quality.

### 8.12.4 DP and DM

When the ISP1705 is in USB mode, the DP pin functions as the USB data plus line, and the DM pin functions as the USB data minus line.

When the ISP1705 is in transparent UART mode, the DP pin functions as the UART RXD input pin, and the DM pin functions as the UART TXD output pin.

The DP and DM pins must be connected to the D+ and D- pins of the USB receptacle.

### 8.12.5 CFG0

This input pin is used to select the SDR or DDR interface. For the SDR interface, connect this pin to GND. For the DDR interface, connect this pin to REG3V3.

### 8.12.6 V<sub>CC</sub>

Main input supply voltage for the ISP1705. The ISP1705 operates correctly when V<sub>CC</sub> is between 3.0 V and 4.5 V. A 0.1  $\mu\text{F}$  decoupling capacitor is recommended.

### 8.12.7 ID

For OTG applications, the ID (identification) pin is connected to the ID pin of the micro-AB receptacle. As defined in *On-The-Go Supplement to the USB 2.0 Specification Rev. 1.3*, the ID pin dictates the initial role of the link. If ID is detected as HIGH, the link must assume the role of a peripheral. If ID is detected as LOW, the link must assume a host role. Roles can be swapped at a later time by using HNP.

The ISP1705 provides an internal pull-up resistor ( $R_{UP(ID)}$ ) to sense the state of the ID pin. The pull-up resistor must first be enabled by setting the ID\_PULLUP register bit to logic 1. If the state of ID has changed, the ISP1705 will send an RXCMD or interrupt to the link. If the link does not receive any RXCMD or interrupt by time  $t_{ID}$ , then the ID state has not changed.

The ISP1705 also provides an internal weak pull-up resistor ( $R_{weakPU(ID)}$ ). This weak pull-up resistor is always enabled to avoid a possible floating condition on the ID pin.

### 8.12.8 FAULT

This pin is used to detect the V<sub>BUS</sub> fault condition. If the function is not used, this pin must be connected to ground to avoid floating input.

If an external V<sub>BUS</sub> overcurrent or fault detection circuit is used, the output fault indicator of that circuit can be connected to the FAULT input pin. The USE\_EXT\_VBUS\_IND bit in the OTG\_CTRL register (see [Section 11.7](#)) and the IND\_PASSTHRU bit in the INTF\_CTRL register (see [Section 11.6](#)) must be set to logic 1. The ISP1705 will inform the link of V<sub>BUS</sub> fault events by sending RXCMDs on the ULPI bus.

The FAULT input pin is mapped to the A\_VBUS\_VLD bit in RXCMD. Any changes to the FAULT input will trigger RXCMD carrying the FAULT condition with A\_VBUS\_VLD.

For details, see [Section 10.3.2](#) and [Section 10.3.3](#).

### 8.12.9 REG3V3 and REG1V8

These are output voltage pins from the internal regulator. These supplies are used internally to power digital and analog circuits.

For proper operation of the regulator, pins REG3V3 and REG1V8 must each be connected to a 0.1  $\mu\text{F}$  capacitor in parallel with a 4.7  $\mu\text{F}$  low ESR capacitor.

REG3V3 powers on-chip pads of the following pins:

- CFG0
- DM
- DP
- FAULT
- ID
- PSW\_N
- RREF

### 8.12.10 $V_{\text{BUS}}$

This I/O pin acts as an input to  $V_{\text{BUS}}$  comparators, and also as a power supply pin for SRP charge and discharge resistors. For details, see [Figure 9](#).

The  $V_{\text{BUS}}$  pin requires a capacitive load. [Table 4](#) provides the recommended capacitor values for various applications.

**Table 4. Recommended  $V_{\text{BUS}}$  capacitor value**

Application	$V_{\text{BUS}}$ capacitor ( $C_{\text{VBUS}}$ )
OTG	1 $\mu\text{F}$ to 6.5 $\mu\text{F}$ , 10 V
Standard host	120 $\mu\text{F} \pm 20\%$ , 10 V
Standard peripheral	1 $\mu\text{F}$ to 10 $\mu\text{F}$ , 10 V

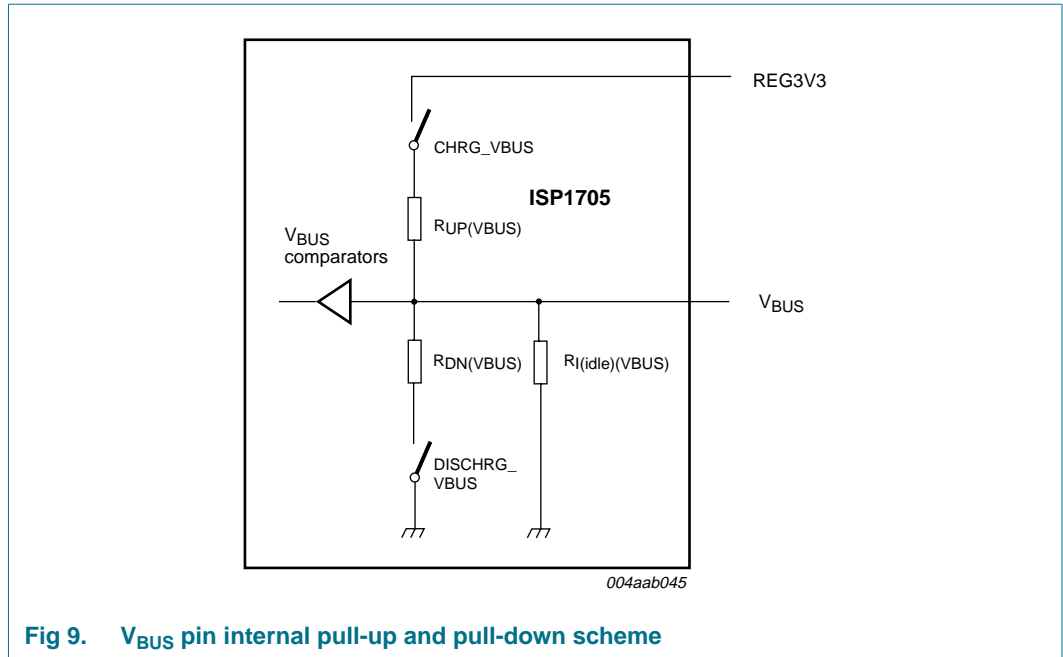

Fig 9. VBUS pin internal pull-up and pull-down scheme

### 8.12.11 PSW\_N

The PSW\_N pin is an active-LOW open-drain output pin. It is used to control external charge pumps or VBUS power switches to supply VBUS. When in use, an external pull-up resistor is required. This allows for per-port or ganged power control.

To enable the external power source by driving PSW\_N to LOW, the link must set the DRV\_VBUS\_EXT bit in the OTG\_CTRL register (see Section 11.7) to logic 1.

Table 5 summarizes settings to drive 5 V on VBUS.

Table 5. OTG\_CTRL register power control bits

DRV_VBUS_EXT	Power source used
0	external 5 V VBUS power source disabled (PSW_N = HIGH)
1	external 5 V VBUS power source enabled (PSW_N = LOW)

### 8.12.12 XTAL1 and XTAL2

XTAL1 is the crystal oscillator input, and XTAL2 is the crystal oscillator output. The allowed crystal or clock frequency on the XTAL1 pin is selectable by the CFG1 and CFG2 pins, as shown in Table 6.

Table 6. Allowed crystal or clock frequency on the XTAL1 pin

Pin CFG1	Pin CFG2	Allowed crystal or clock frequency on the XTAL1 pin
LOW	LOW	19.2 MHz
LOW	HIGH	26 MHz
HIGH	LOW	24 MHz
HIGH	HIGH	13 MHz

When a clock is driven into XTAL1, XTAL2 must be left open.

If a crystal is attached, it requires a capacitor on each terminal of the crystal to GND. The recommended crystal specification and required external capacitors are given in [Table 7](#) and [Table 8](#).

**Table 7. External capacitor values for 13 MHz or 19.2 MHz clock frequency**

Load capacitance $C_L$ of the crystal <sup>[1]</sup>	Maximum series resistance $R_S$ of the crystal <sup>[1]</sup>	External capacitor $C_{XTAL}$ value
10 pF	< 180 $\Omega$	18 pF
20 pF	< 100 $\Omega$	39 pF

[1] Specified by the crystal manufacturer.

**Table 8. External capacitor values for 24 MHz or 26 MHz clock frequency**

Load capacitance $C_L$ of the crystal <sup>[1]</sup>	Maximum series resistance $R_S$ of the crystal <sup>[1]</sup>	External capacitor $C_{XTAL}$ value
10 pF	< 140 $\Omega$	18 pF
20 pF	< 60 $\Omega$	39 pF

[1] Specified by the crystal manufacturer.

### 8.12.13 DIR

ULPI direction output pin. Synchronous to the rising edge of CLOCK. Controls the direction of the data bus. By default, the ISP1705 holds DIR at LOW, causing the data bus to be an input. When DIR is LOW, the ISP1705 listens for data from the link. The ISP1705 pulls DIR to HIGH only when it has data to send to the link, which is for one of two reasons:

- To send data (USB receive or register reads) and RXCMD status updates to the link.
- To block the link from driving the data bus during power-up, reset and low power (suspend) mode.

This pin can be 3-stated when chip select is deasserted.

### 8.12.14 RESET\_N

An active-LOW asynchronous reset pin that resets all circuits in the ISP1705. The ISP1705 contains an internal power-on reset circuit, and therefore using the RESET\_N pin is optional. If RESET\_N is not used, it must be connected to  $V_{CC(I/O)}$ .

For details on using RESET\_N, see [Section 8.11.2](#).

### 8.12.15 STP

ULPI stop input pin. Synchronous to the rising edge of CLOCK. The link must assert STP to signal the end of a USB transmit packet or a register write operation. When DIR is asserted, the link can optionally assert STP for one clock cycle to abort the ISP1705, causing it to deassert DIR in the next clock cycle.

### 8.12.16 NXT

ULPI next data output pin. Synchronous to the rising edge of CLOCK. The ISP1705 holds NXT at LOW, by default. When DIR is LOW and the link is sending data to the ISP1705, NXT will be asserted to notify the link to provide the next data byte. When DIR is HIGH

and the ISP1705 is sending data to the link, NXT will be asserted to notify the link that another valid byte is on the bus. NXT is not used for register read data or the RXCMD status update.

This pin can be 3-stated when chip select is deasserted.

#### 8.12.17 CLOCK

A 60 MHz interface clock to synchronize the ULPI bus. All ULPI pins are synchronous to the rising edge of CLOCK.

The ISP1705 provides two clocking options:

- A crystal is attached between the XTAL1 and XTAL2 pins.
- A clock is driven into the XTAL1 pin, with the XTAL2 pin left unconnected.

#### 8.12.18 CFG1, CFG2

These input pins are used to select the crystal or clock frequency. For details, see [Table 6](#).

#### 8.12.19 CHIP\_SEL, CHIP\_SEL\_N

When chip select is deasserted, ULPI pins DATA[7:0], CLOCK, DIR and NXT are 3-stated and the STP input is ignored; internal circuits are powered-down as well.

When chip select is asserted, the ISP1705 will operate normally.

Both the CHIP\_SEL and CHIP\_SEL\_N pins must be asserted for the chip select to function. If any of the two is deasserted, the chip will enter Power-down mode.

#### 8.12.20 GND

Global ground signal. To ensure the correct operation of the ISP1705, GND must be soldered to the cleanest available ground.

## 9. Modes of operation

### 9.1 Power modes

When both  $V_{CC(I/O)}$  and  $V_{CC}$  are not powered, there will be no leakage from the  $V_{BUS}$  pin to all the remaining pins, including  $V_{CC}$  and  $V_{CC(I/O)}$ . Applying  $V_{BUS}$  within the normal range will not damage the ISP1705 chip.

When both  $V_{CC}$  and  $V_{CC(I/O)}$  are powered and are within the operating voltage range, the ISP1705 will be fully functional as in normal mode.

When  $V_{CC(I/O)}$  is powered and the  $V_{CC}$  voltage is below the operating range of the ISP1705, the application system must detect the low voltage condition and set chip select to deassert (that is, put the ISP1705 in Power-down mode). This is to protect the ULPI and USB interfaces from driving wrong levels. Under this condition, the  $V_{CC(I/O)}$  voltage will not leak to USB pins ( $V_{BUS}$ , DP, DM and ID) and the  $V_{CC}$  pin. All the digital pins (see [Section 8.12.2](#)) powered by  $V_{CC(I/O)}$  are configured as high-impedance inputs. These pins must be driven to a defined state or terminated by using pull-up or pull-down resistors to avoid a floating input condition. Other pins (see [Section 8.12.9](#)) are not powered.

#### 9.1.1 Normal mode

In normal mode, both  $V_{CC}$  and  $V_{CC(I/O)}$  are powered. Chip select is asserted. The ISP1705 is fully functional.

#### 9.1.2 Power-down mode

When  $V_{CC(I/O)}$  is not present or when chip select is deasserted, the ISP1705 is put into Power-down mode. In this mode, internal regulators are powered down to keep the  $V_{CC}$  current to a minimum. The voltage on the  $V_{CC}$  pin will not leak to the  $V_{CC(I/O)}$  and/or  $V_{BUS}$  pins. In this mode, the ISP1705 pin states are given in [Table 9](#).

**Table 9. Pin states in Power-down mode**

Pin name <sup>[1]</sup>	Pin state when $V_{CC(I/O)}$ is not present	Pin state when $V_{CC(I/O)}$ is present and chip select is not active
$V_{CC}$	3.0 V to 4.5 V	3.0 V to 4.5 V
$V_{CC(I/O)}$	not powered <sup>[2]</sup>	3.0 V to 3.6 V
CHIP_SEL, CHIP_SEL_N	not powered <sup>[2]</sup>	HIGH
CFG1, CFG2, RESET_N, CLOCK, STP, NXT, DIR, DATA[7:0]	not powered <sup>[2]</sup>	3.0 V to 3.3 V
CFG0, DP, DM, $V_{BUS}$ , ID, REG1V8, REG3V3, XTAL1, XTAL2, RREF, PSW_N, FAULT	not powered <sup>[2]</sup>	not powered <sup>[2]</sup>

[1] When I/O pins are not powered, the input buffer is disabled and will ignore the external input level. The input pins, however, should not be driven by another voltage source to prevent leakage.

[2] These pins must not be externally driven to HIGH. Otherwise, the ISP1705 behavior is undefined and leakage current will occur.

When  $V_{CC(I/O)}$  is not present, all the digital pins (see [Section 8.12.2](#)) that are powered by  $V_{CC(I/O)}$  are not powered. Other pins (see [Section 8.12.9](#)) are also not powered.

When the ISP1705 is put into Power-down mode by disabling chip select, all the digital pins (see [Section 8.12.2](#)) that are powered by  $V_{CC(I/O)}$  are configured as high-impedance inputs. These pins must be driven to defined states or terminated by using pull-up or pull-down resistors to avoid a floating input condition. Other pins (see [Section 8.12.9](#)) are not powered. In this mode, minimum current will be drawn by  $V_{CC(I/O)}$  to detect the chip select status.

## 9.2 ULPI modes

The ISP1705 ULPI interface can be programmed to operate in five modes. In each mode, the signals on the data bus are reconfigured as described in the following subsections. Setting more than one mode will lead to undefined behavior.

### 9.2.1 Synchronous mode

This is default mode. On power-up, and when CLOCK is stable, the ISP1705 will enter synchronous mode.

In synchronous mode, the link must synchronize all ULPI signals to CLOCK, meeting the set-up and hold times as defined in [Section 15](#).

This mode is used by the link to perform the following tasks:

- High-speed detection handshake (chirp)
- Transmit and receive USB packets
- Read from and write to registers
- Receive USB status updates (RXCMDs) from the ISP1705

For more information on various synchronous mode protocols, see [Section 10](#).

**Table 10. ULPI signal description**

Signal name	Direction on the ISP1705 <sup>[1]</sup>	Signal description
CLOCK	O	<b>60 MHz interface clock:</b> When a crystal is attached or a clock is driven into the XTAL1 pin, the ISP1705 will drive a 60 MHz output clock. During low-power, serial and UART modes, the clock can be turned off to save power.
DATA[7:0]	I/O	<b>8-bit data bus:</b> In synchronous mode, the link drives DATA[7:0] to LOW by default. The link initiates transfers by sending a nonzero data pattern called a TXCMD (transmit command). In synchronous mode, the direction of DATA[7:0] is controlled by DIR. Contents of DATA[7:0] lines must be ignored for exactly one clock cycle whenever DIR changes state. This is called a turnaround cycle. Data lines have fixed directions and different meanings in low-power, 3-pin serial and UART modes.



Table 10. ULPI signal description ...continued

Signal name	Direction on the ISP1705 <sup>[1]</sup>	Signal description
DIR	O	<p><b>Direction:</b> Controls the direction of data bus DATA[7:0].</p> <p>In synchronous mode, the ISP1705 drives DIR to LOW by default, making the data bus an input so the ISP1705 can listen for TXCMD from the link. The ISP1705 drives DIR to HIGH only when it has data for the link. When DIR and NXT are HIGH, the byte on the data bus contains decoded USB data. When DIR is HIGH and NXT is LOW, the byte contains status information called an RXCMD (receive command). The only exception to this rule is when the PHY returns register read data, where NXT is also LOW, replacing the usual RXCMD byte. Every change in DIR causes a turnaround cycle on the data bus, during which DATA[7:0] is not valid and must be ignored by the link.</p> <p>DIR is always asserted during low-power, serial and UART modes.</p>
STP	I	<p><b>Stop:</b> In synchronous mode, the link drives STP to HIGH for one cycle after the last byte of data is sent to the ISP1705. The link can optionally assert STP to force DIR to be deasserted.</p> <p>In low-power, serial and UART modes, the link holds STP at HIGH to wake up the ISP1705, causing the ULPI bus to return to synchronous mode.</p>
NXT	O	<p><b>Next:</b> In synchronous mode, the ISP1705 drives NXT to HIGH to throttle data. If DIR is LOW, the ISP1705 asserts NXT to notify the link to place the next data byte on DATA[7:0] in the following clock cycle. If DIR is HIGH, the ISP1705 asserts NXT to notify the link that a valid USB data byte is on DATA[7:0] in the current cycle. The ISP1705 always drives an RXCMD when DIR is HIGH and NXT is LOW, unless register read data is to be returned to the link in the current cycle.</p> <p>NXT is not used in low-power, serial and UART modes.</p>

[1] I = input; O = output.

### 9.2.2 Low-power mode

When the USB bus is idle, the link can place the ISP1705 into low-power mode (also called suspend mode). In low-power mode, the data bus definition changes to that shown in [Table 11](#). To enter low-power mode, the link sets the SUSPENDM bit in the FUNC\_CTRL register (see [Section 11.5](#)) to logic 0. To exit low-power mode, the link asserts the STP signal. After exiting low-power mode, the ISP1705 will send an RXCMD to the link if a change was detected in any interrupt source, and the change still exists. An RXCMD may not be sent if the interrupt condition is removed before exiting.

The ISP1705 will draw only suspend current from the V<sub>CC</sub> supply; see [Table 53](#).

During low-power mode, the clock on XTAL1 may be stopped. The clock must be started again before asserting STP to exit low-power mode.

For more information on low-power mode enter and exit protocols, refer to *UTMI+ Low Pin Interface (ULPI) Specification Rev. 1.1*.

Table 11. Signal mapping during low-power mode

Signal	Maps to	Direction <sup>[1]</sup>	Description
LINESTATE0	DATA0	O	combinatorial LINESTATE0 directly driven by the analog receiver
LINESTATE1	DATA1	O	combinatorial LINESTATE1 directly driven by the analog receiver

**Table 11. Signal mapping during low-power mode ...continued**

Signal	Maps to	Direction <sup>[1]</sup>	Description
Reserved	DATA2	O	reserved; the ISP1705 will drive this pin to LOW
INT	DATA3	O	active-HIGH interrupt indication; will be asserted and latched whenever any unmasked interrupt occurs
Reserved	DATA[7:4]	O	reserved; the ISP1705 will drive these pins to LOW

[1] I = input; O = output.

### 9.2.3 6-pin full-speed or low-speed serial mode

If the link requires a 6-pin serial interface to transmit and receive full-speed or low-speed USB data, it can set the ISP1705 to 6-pin serial mode. In 6-pin serial mode, the data bus definition changes to that shown in [Table 12](#). To enter 6-pin serial mode, the link sets the 6PIN\_FSL\_SERIAL bit in the INTF\_CTRL register (see [Section 11.6](#)) to logic 1. To exit 6-pin serial mode, the link asserts the STP signal. This is provided primarily for links that contain legacy full-speed or low-speed functionality, providing a more cost-effective upgrade path to high-speed functionality. An interrupt pin is also provided to inform the link of USB events. If the link requires CLOCK to be running during 6-pin serial mode, the CLOCK\_SUSPENDM register bit must be set to logic 1 before entering 6-pin serial mode.

For more information on 6-pin serial mode enter and exit protocols, refer to *UTMI+ Low Pin Interface (ULPI) Specification Rev. 1.1*.

**Table 12. Signal mapping for 6-pin serial mode**

Signal	Maps to	Direction <sup>[1]</sup>	Description
TX_ENABLE	DATA0	I	active-HIGH transmit enable
TX_DAT	DATA1	I	transmit differential data on DP and DM
TX_SE0	DATA2	I	transmit single-ended zero on DP and DM
INT	DATA3	O	active-HIGH interrupt indication; will be asserted and latched whenever any unmasked interrupt occurs
RX_DP	DATA4	O	single-ended receive data from DP
RX_DM	DATA5	O	single-ended receive data from DM
RX_RCV	DATA6	O	differential receive data from DP and DM
Reserved	DATA7	O	reserved; the ISP1705 will drive this pin to LOW

[1] I = input; O = output.

### 9.2.4 3-pin full-speed or low-speed serial mode

If the link requires a 3-pin serial interface to transmit and receive full-speed or low-speed USB data, it can set the ISP1705 to 3-pin serial mode. In 3-pin serial mode, the data bus definition changes to that shown in [Table 13](#). To enter 3-pin serial mode, the link sets the 3PIN\_FSL\_SERIAL bit in the INTF\_CTRL register (see [Section 11.6](#)) to logic 1. To exit 3-pin serial mode, the link asserts the STP signal. This is provided primarily for links that contain legacy full-speed or low-speed functionality, providing a more cost-effective upgrade path to high-speed functionality. An interrupt pin is also provided to inform the link of USB events. If the link requires CLOCK to be running during 3-pin serial mode, the CLOCK\_SUSPENDM register bit must be set to logic 1 before entering 3-pin serial mode.

For more information on 3-pin serial mode enter and exit protocols, refer to *UTMI+ Low Pin Interface (ULPI) Specification Rev. 1.1*.

**Table 13. Signal mapping for 3-pin serial mode**

Signal	Maps to	Direction <sup>[1]</sup>	Description
TX_ENABLE	DATA0	I	active-HIGH transmit enable
DAT	DATA1	I/O	transmit differential data on DP and DM when TX_ENABLE is HIGH receive differential data from DP and DM when TX_ENABLE is LOW
SE0	DATA2	I/O	transmit single-ended zero on DP and DM when TX_ENABLE is HIGH receive single-ended zero from DP and DM when TX_ENABLE is LOW
INT	DATA3	O	active-HIGH interrupt indication; will be asserted and latched whenever any unmasked interrupt occurs
Reserved	DATA[7:4]	O	reserved; the ISP1705 will drive these pins to LOW

[1] I = input; O = output.

### 9.2.5 Transparent UART mode

In transparent UART mode, the ISP1705 functions as a voltage level shifter between following pins:

- From pin DATA0 ( $V_{CC(I/O)}$  level) to pin DM (2.7 V level).
- From pin DP (2.7 V level) to pin DATA1 ( $V_{CC(I/O)}$  level).

The USB transceiver is used to drive the UART transmitting signal on the DM line. The rise time and the fall time of the transmitting signal is determined by whether a full-speed or low-speed transceiver is in use. It is recommended to use a low-speed transceiver if the UART bit rate is below 921 kbit/s for better EMI performance. If the UART bit rate is equal to or above 921 kbit/s, a full-speed transceiver can be used.

In transparent UART mode, data bus definitions change to that shown in [Table 14](#).

**Table 14. UART signal mapping**

Signal	Maps to	Direction <sup>[1]</sup>	Description
TXD	DATA0	I	UART TXD signal that is routed to the DM pin
RXD	DATA1	O	UART RXD signal that is routed from the DP pin
Reserved	DATA2	O	reserved; the ISP1705 will drive this pin to LOW in UART mode
INT	DATA3	O	active-HIGH interrupt indication; will be asserted and latched whenever any unmasked interrupt occurs
Reserved	DATA[7:4]	O	reserved; the ISP1705 will drive these pins to LOW in UART mode

[1] I = input; O = output.

Transparent UART mode is entered by setting some register bits in ULPI registers. The recommended sequence is:

1. Set the XCVRSELECT[1:0] bits in the FUNC\_CTRL register (see [Section 11.5](#)) to 10b (low speed) or 01b (full speed). This setting affects the rise time and the fall time of the UART transmitting signal on the DM line.
2. Set the DP\_PULLDOWN and DM\_PULLDOWN bits in the OTG\_CTRL register (see [Section 11.7](#)) to logic 0.
3. Set the TERMSELECT bit in the FUNC\_CTRL register (see [Section 11.5](#)) to logic 0 (power-on default value).  
**Remark:** Mandatory when a full-speed driver is used and optional for a low-speed driver.
4. Set the TXD\_EN and RXD\_EN bits in the CARKIT\_CTRL register (see [Section 11.14](#)) to logic 1. These two bits must be set together in one TXCMD.
5. Set the CARKIT\_MODE bit in the INTF\_CTRL register (see [Section 11.6](#)) to logic 1.  
**Remark:** The CARKIT\_MODE, TXD\_EN and RXD\_EN bits must be set to logic 1. The sequence of setting these register bits is ignored.

After the register configuration is complete:

1. A weak pull-up resistor will be enabled on the DP and DATA0 pins. This is to avoid the possible floating condition on these input pins when UART mode is enabled.
2. The 39  $\Omega$  serial termination resistors on the DP and DM pins will be enabled.
3. One clock cycle after DIR goes from LOW to HIGH, the ISP1705 will drive the data bus for five clock cycles. This is to charge the DATA0 pin to a HIGH level for a slow link. However, the link can start driving DATA0 to HIGH immediately after the turnaround cycle.
4. UART buffers between DATA0 or DATA1 and DM or DP are enabled. Transparent UART mode is entered.  
**Remark:** The DP pin will be slowly charged up to HIGH by the weak pull-up resistor. The time needed depends on the capacitive loading on DP.

By default, the clock is powered down when the ISP1705 enters UART mode. If the link requires CLOCK to be running in UART mode, it can set the CLOCK\_SUSPENDM bit in the INTF\_CTRL register (see [Section 11.6](#)) to logic 1 before entering UART mode.

Transparent UART mode is exited by asserting the STP pin to HIGH or by toggling chip select.

The INT pin (DATA3) is asserted and latched whenever an unmasked interrupt event occurs. When the link detects INT as HIGH, it must wake up the PHY from transparent UART mode by asserting STP. When the PHY is in synchronous mode, the link can read the USB\_INTR\_L register (see [Section 11.11](#)) to determine the source of the interrupt. Note that the ISP1705 does not implement the optional Carkit Interrupt registers.

An alternative way to exit UART mode is to set chip select to non-active for more than  $t_{PWRDN}$  and then set it to active. A power-on reset will be generated and the ULPI bus will be put in default synchronous mode.

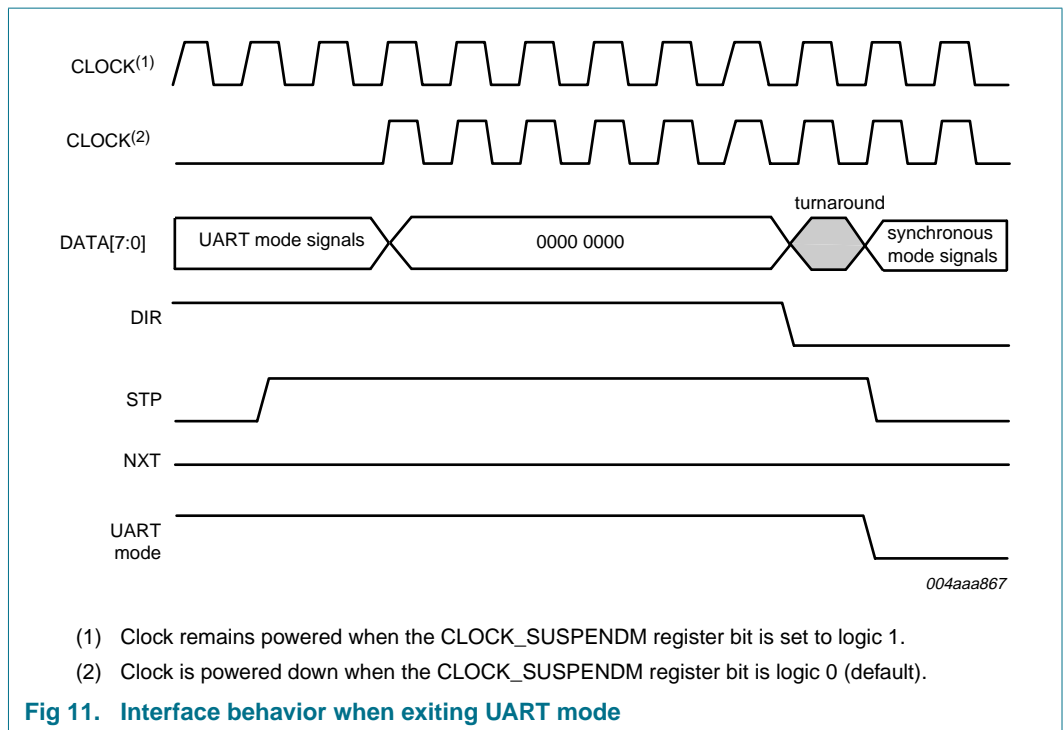
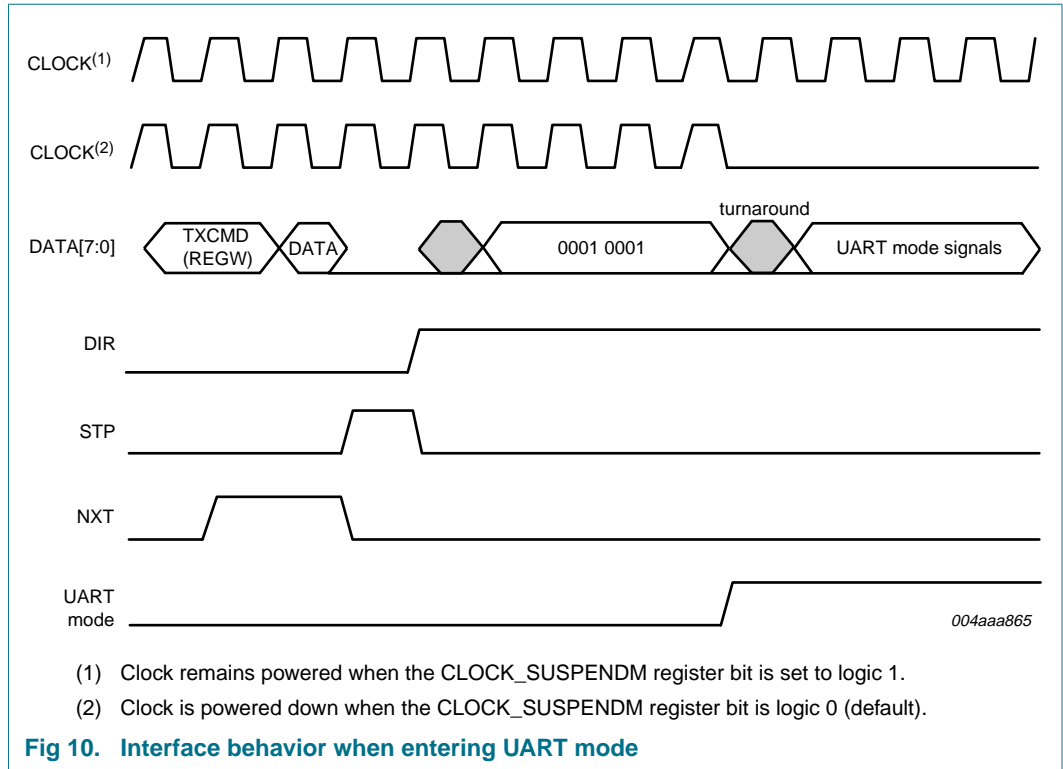

### 9.3 USB state transitions

A Hi-Speed USB peripheral, host or OTG device handles more than one electrical state as defined in *Universal Serial Bus Specification Rev. 2.0* and *On-The-Go Supplement to the USB 2.0 Specification Rev. 1.3*. The ISP1705 accommodates various states through register settings of the XCVRSELECT[1:0], TERMSELECT, OPMODE[1:0], DP\_PULLDOWN and DM\_PULLDOWN bits.

[Table 15](#) summarizes operating states. The values of register settings in [Table 15](#) will force resistor settings as also given in [Table 15](#). Resistor setting signals are defined as follows:

- RPU\_DP\_EN enables the 1.5 kΩ pull-up resistor on DP
- RPD\_DP\_EN enables the 15 kΩ pull-down resistor on DP
- RPD\_DM\_EN enables the 15 kΩ pull-down resistor on DM
- HSTERM\_EN enables the 45 Ω termination resistors on DP and DM

It is up to the link to set the desired register settings.

**Table 15. Operating states and their corresponding resistor settings**

Signaling mode	Register settings					Internal resistor settings			
	XCVR SELECT [1:0]	TERM SELECT	OPMODE [1:0]	DP_PULL DOWN	DM_PULL DOWN	RPU_DP_EN	RPD_DP_EN	RPD_DM_EN	HSTERM_EN
<b>General settings</b>									
3-state drivers	XXb	Xb	01b	Xb	Xb	0b	0b	0b	0b
Power up or V <sub>BUS</sub> < V <sub>B_SESS_END</sub>	01b	0b	00b	1b	1b	0b	1b	1b	0b
<b>Host settings</b>									
Host chirp	00b	0b	10b	1b	1b	0b	1b	1b	1b
Host high-speed	00b	0b	00b	1b	1b	0b	1b	1b	1b
Host full-speed	X1b	1b	00b	1b	1b	0b	1b	1b	0b
Host high-speed or full-speed suspend	01b	1b	00b	1b	1b	0b	1b	1b	0b
Host high-speed or full-speed resume	01b	1b	10b	1b	1b	0b	1b	1b	0b
Host low-speed	10b	1b	00b	1b	1b	0b	1b	1b	0b
Host low-speed suspend	10b	1b	00b	1b	1b	0b	1b	1b	0b
Host low-speed resume	10b	1b	10b	1b	1b	0b	1b	1b	0b
Host Test J or Test K	00b	0b	10b	1b	1b	0b	1b	1b	1b
<b>Peripheral settings</b>									
Peripheral chirp	00b	1b	10b	0b	0b	1b	0b	0b	0b
Peripheral high speed	00b	0b	00b	0b	0b	0b	0b	0b	1b
Peripheral full speed	01b	1b	00b	0b	0b	1b	0b	0b	0b

Table 15. Operating states and their corresponding resistor settings ...continued

Signaling mode	Register settings					Internal resistor settings			
	XCVR SELECT [1:0]	TERM SELECT	OPMODE [1:0]	DP_ PULL DOWN	DM_ PULL DOWN	RPU_ DP_EN	RPD_ DP_EN	RPD_ DM_EN	HSTERM_ EN
Peripheral high speed or full speed suspend	01b	1b	00b	0b	0b	1b	0b	0b	0b
Peripheral high speed or full speed resume	01b	1b	10b	0b	0b	1b	0b	0b	0b
Peripheral Test J or Test K	00b	0b	10b	0b	0b	0b	0b	0b	1b
<b>OTG settings</b>									
OTG device peripheral chirp	00b	1b	10b	0b	1b	1b	0b	1b	0b
OTG device peripheral high speed	00b	0b	00b	0b	1b	0b	0b	1b	1b
OTG device peripheral full speed	01b	1b	00b	0b	1b	1b	0b	1b	0b
OTG device peripheral high speed and full speed suspend	01b	1b	00b	0b	1b	1b	0b	1b	0b
OTG device peripheral high speed and full speed resume	01b	1b	10b	0b	1b	1b	0b	1b	0b
OTG device peripheral Test J or Test K	00b	0b	10b	0b	1b	0b	0b	1b	1b

## 10. Protocol description

### 10.1 ULPI references

The ISP1705 provides a 12-pin ULPI interface to communicate with the link. It is highly recommended that users of the ISP1705 read *UTMI+ Specification Rev. 1.0* and *UTMI+ Low Pin Interface (ULPI) Specification Rev. 1.1*.

Commands between the ISP1705 and the link are described in the following subsections.

### 10.2 TXCMD

By default, the link must drive the ULPI bus to its idle state of 00h. To send commands and USB packets, the link drives a nonzero value on DATA[7:0] to the ISP1705 by sending a byte called TXCMD. Commands include USB packet transmissions, and register reads and writes. Once the TXCMD is interpreted and accepted by the ISP1705, the NXT signal is asserted and the link can follow up with the required number of data bytes. The TXCMD byte format is given in [Table 16](#). Any values other than those in [Table 16](#) are illegal and will result in undefined behavior.

Various TXCMD packet and register sequences are given in later sections.

**Table 16. TXCMD byte format**

Command type name	Command code DATA[7:6]	Command payload DATA[5:0]	Command name	Command description
Idle	00b	00 0000b	NOOP	No operation. 00h is the idle value of the data bus. The link must drive NOOP by default.
Packet transmit	01b	00 0000b	NOPID	Transmit USB data that does not have a PID, such as chirp and resume signaling. The ISP1705 starts transmitting only after accepting the next data byte.
		00 XXXXb	PID	Transmit USB packet. DATA[3:0] indicates USB packet identifier PID[3:0].
Register write	10b	10 1111b	EXTW	Extended register write command (optional). The 8-bit address must be provided after the command is accepted.
		XX XXXXb	REGW	Register write command with 6-bit immediate address.
Register read	11b	10 1111b	EXTR	Extended register read command (optional). The 8-bit address must be provided after the command is accepted.
		XX XXXXb	REGR	Register read command with 6-bit immediate address.

### 10.3 RXCMD

The ISP1705 communicates status information to the link by asserting DIR and sending an RXCMD byte on the data bus. The RXCMD data byte format follows *UTMI+ Low Pin Interface (ULPI) Specification Rev. 1.1* and is given in [Table 17](#).



The ISP1705 will automatically send an RXCMD whenever there is a change in any of the RXCMD data fields. The link must be able to accept an RXCMD at any time; including single RXCMDs, back-to-back RXCMDs, and RXCMDs at any time during USB receive packets when NXT is LOW. An example is shown in [Figure 12](#). For details and diagrams, refer to *UTMI+ Low Pin Interface (ULPI) Specification Rev. 1.1*.

**Table 17. RXCMD byte format**

DATA	Name	Description and value
1 to 0	LINESTATE	<b>LINESTATE signals:</b> For a definition of LINESTATE, see <a href="#">Section 10.3.1</a> . <b>DATA0</b> — LINESTATE0 <b>DATA1</b> — LINESTATE1
3 to 2	V <sub>BUS</sub> state	<b>Encoded V<sub>BUS</sub> voltage state:</b> For an explanation of the V <sub>BUS</sub> state, see <a href="#">Section 10.3.2</a> .
5 to 4	RxEvent	<b>Encoded USB event signals:</b> For an explanation of RxEvent, see <a href="#">Section 10.3.4</a> .
6	ID	Reflects the state of the ID pin. Valid 50 ms after ID_PULLUP is set to logic 1.
7	ALT_INT	By default, this signal is not used and is not needed in typical designs. Optionally, the link can enable the BVALID_RISE and/or BVALID_FALL bits in the PWR_CTRL register (see <a href="#">Section 11.15</a> ). Corresponding changes in BVALID will cause an RXCMD to be sent to the link with the ALT_INT bit asserted.

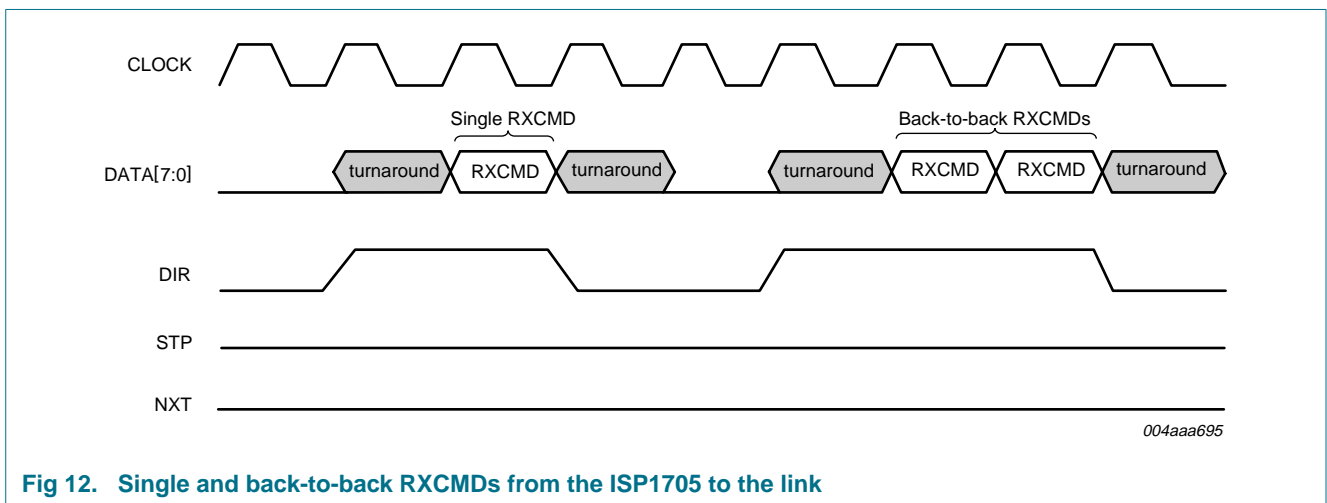

**Fig 12. Single and back-to-back RXCMDs from the ISP1705 to the link**

### 10.3.1 Linestate encoding

LINESTATE[1:0] reflects the current state of DP and DM. Whenever the ISP1705 detects a change in DP or DM, an RXCMD will be sent to the link with the new LINESTATE[1:0] value. The value given on LINESTATE[1:0] depends on the setting of various registers.

[Table 18](#) shows the LINESTATE[1:0] encoding for upstream facing ports, which applies to peripherals. [Table 19](#) shows the LINESTATE[1:0] encoding for downstream facing ports, which applies to host controllers. Dual-role devices must choose the correct table, depending on whether it is in peripheral or host mode.

**Table 18. LINESTATE[1:0] encoding for upstream facing ports: peripheral**  
*DP\_PULLDOWN = 0.*<sup>[1]</sup>

Mode	Value	Full speed	High speed	Chirp
XCVRSELECT[1:0]		01, 11	00	00
TERMSELECT		1	0	1
LINESTATE[1:0]	00	SE0	squelch	squelch
	01	FS-J	!squelch	!squelch and HS_Differential_Receiver_Output
	10	FS-K	invalid	!squelch and !HS_Differential_Receiver_Output
	11	SE1	invalid	invalid

[1] !squelch indicates inactive squelch. !HS\_Differential\_Receiver\_Output indicates inactive HS\_Differential\_Receiver\_Output.

**Table 19. LINESTATE[1:0] encoding for downstream facing ports: host**  
*DP\_PULLDOWN and DM\_PULLDOWN = 1.*<sup>[1]</sup>

Mode	Value	Low speed	Full speed	High speed	Chirp
XCVRSELECT[1:0]		10	01, 11	00	00
TERMSELECT		1	1	0	0
OPMODE[1:0]		X	X	00, 01 or 11	10
LINESTATE[1:0]	00	SE0	SE0	squelch	squelch
	01	LS-K	FS-J	!squelch	!squelch and HS_Differential_Receiver_Output
	10	LS-J	FS-K	invalid	!squelch and !HS_Differential_Receiver_Output
	11	SE1	SE1	invalid	invalid

[1] !squelch indicates inactive squelch. !HS\_Differential\_Receiver\_Output indicates inactive HS\_Differential\_Receiver\_Output.

### 10.3.2 V<sub>BUS</sub> state encoding

USB devices must monitor the V<sub>BUS</sub> voltage for purposes such as overcurrent detection, starting a session and SRP. The V<sub>BUS</sub> state field in the RXCMD is an encoding of the voltage level on V<sub>BUS</sub>.

The SESS\_END and SESS\_VLD indicators in the V<sub>BUS</sub> state are directly taken from the internal comparators built-in to the ISP1705, and encoded as shown in [Table 17](#) and [Table 20](#).

**Table 20. Encoded V<sub>BUS</sub> voltage state**

Value	V <sub>BUS</sub> voltage	SESS_END	SESS_VLD	A_VBUS_VLD
00	V <sub>BUS</sub> < V <sub>B_SESS_END</sub>	1	0	0
01	V <sub>B_SESS_END</sub> ≤ V <sub>BUS</sub> < V <sub>A_SESS_VLD</sub>	0	0	0
10	V <sub>A_SESS_VLD</sub> ≤ V <sub>BUS</sub> < V <sub>A_VBUS_VLD</sub>	X	1	0
11	V <sub>BUS</sub> ≥ V <sub>A_VBUS_VLD</sub>	X	X	1

The A\_VBUS\_VLD indicator in the V<sub>BUS</sub> state provides several options and must be configured based on current draw requirements. A\_VBUS\_VLD can input from one or more V<sub>BUS</sub> voltage indicators, as shown in [Figure 13](#).

A description on how to use and select the V<sub>BUS</sub> state encoding is given in [Section 10.3.3](#).

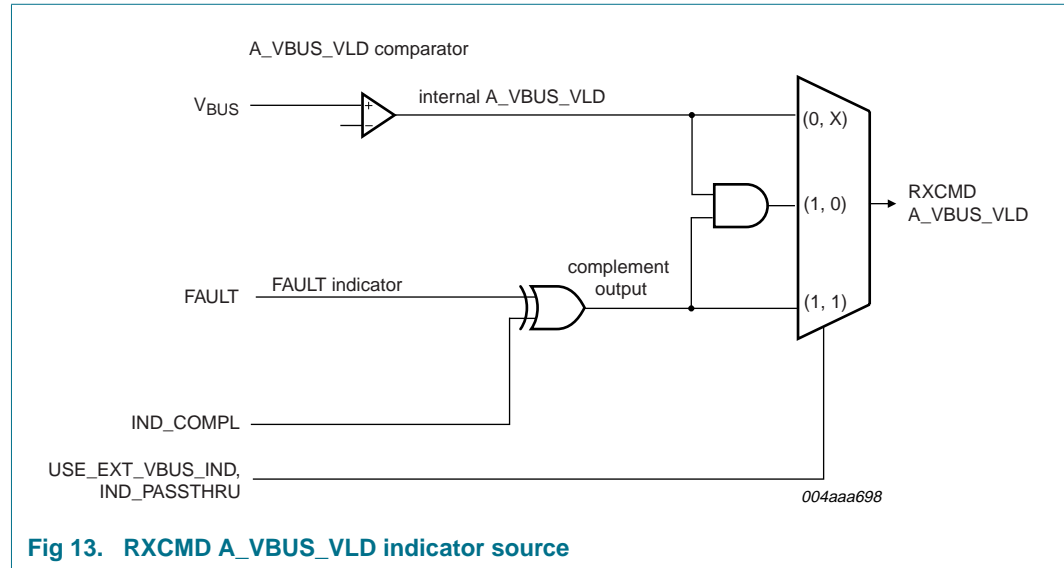

Fig 13. RXCMD A\_VBUS\_VLD indicator source

### 10.3.3 Using and selecting the V<sub>BUS</sub> state encoding

The V<sub>BUS</sub> state encoding is shown in [Table 20](#). The ISP1705 will send an RXCMD to the link whenever there is a change in the V<sub>BUS</sub> state. To receive V<sub>BUS</sub> state updates, the link must first enable the corresponding interrupts in the USB\_INTR\_EN\_R and USB\_INTR\_EN\_F registers.

The link can use the V<sub>BUS</sub> state to monitor V<sub>BUS</sub> and take appropriate actions. [Table 21](#) shows the recommended usage for typical applications.

Table 21. V<sub>BUS</sub> indicators in RXCMD required for typical applications

Application	A_VBUS_VLD	SESS_VLD	SESS_END
Standard host	yes	no	no
Standard peripheral	no	yes	no
OTG A-device	yes	yes	no
OTG B-device	no	yes	yes

#### 10.3.3.1 Standard USB host controllers

For standard hosts, the system must be able to provide 500 mA on V<sub>BUS</sub> in the range of 4.75 V to 5.25 V. An external circuit must be used to detect overcurrent conditions. If the external overcurrent detector provides a digital fault signal, then the fault signal must be connected to the ISP1705 FAULT input pin, and the link must do the following:

1. Set the IND\_COMPL bit in the INTF\_CTRL register (see [Section 11.6](#)) to logic 0 or logic 1, depending on the polarity of the external fault signal.
2. Set the USE\_EXT\_VBUS\_IND bit in the OTG\_CTRL register (see [Section 11.7](#)) to logic 1.

3. If it is not necessary to qualify the fault indicator with the internal A\_VBUS\_VLD comparator, set the IND\_PASSTHRU bit in the INTF\_CTRL register (see [Section 11.6](#)) to logic 1.

**10.3.3.2 Standard USB peripheral controllers**

Standard peripherals must be able to detect when V<sub>BUS</sub> is at a sufficient level for operation. SESS\_VLD must be enabled to detect the start and end of USB peripheral operations. Detection of A\_VBUS\_VLD and SESS\_END thresholds is not needed for standard peripherals.

**10.3.3.3 OTG devices**

When an OTG device is configured as an OTG A-device, it must be able to provide a minimum of 8 mA on V<sub>BUS</sub>. If the OTG A-device provides less than 100 mA, then there is no need for an overcurrent detection circuit because the internal A\_VBUS\_VLD comparator is sufficient. If the OTG A-device provides more than 100 mA on V<sub>BUS</sub>, an overcurrent detector must be used and [Section 10.3.3.1](#) applies. The OTG A-device also uses SESS\_VLD to detect when an OTG B-device is initiating V<sub>BUS</sub> pulsing SRP.

When an OTG device is configured as an OTG B-device, SESS\_VLD must be used to detect when V<sub>BUS</sub> is at a sufficient level for operation. SESS\_END must be used to detect when V<sub>BUS</sub> has dropped to a LOW level, allowing the B-device to safely initiate V<sub>BUS</sub> pulsing SRP.

**10.3.4 RxEvent encoding**

The RxEvent field (see [Table 22](#)) of the RXCMD informs the link of information related packets received on the USB bus. RxActive and RxError are defined in *USB 2.0 Transceiver Macrocell Interface (UTMI) Specification Ver. 1.05*. HostDisconnect is defined in *UTMI+ Specification Rev. 1.0*. A short definition is also given in the following subsections.

**Table 22. Encoded USB event signals**

Value	RxActive	RxError	HostDisconnect
00	0	0	0
01	1	0	0
11	1	1	0
10	X	X	1

**10.3.4.1 RxActive**

When the ISP1705 has detected a SYNC pattern on the USB bus, it signals an RxActive event to the link. An RxActive event can be communicated using two methods. The first method is for the ISP1705 to simultaneously assert DIR and NXT. The second method is for the ISP1705 to send an RXCMD to the link with the RxActive field in the RxEvent bits set to logic 1. The link must be capable of detecting both methods. RxActive frames the receive packet from the first byte to the last byte.

The link must assume that RxActive is set to logic 0 when indicated in an RXCMD or when DIR is deasserted, whichever occurs first.

The link uses RxActive to time high-speed packets and ensure that bus turnaround times are met. For more information on the USB packet timing, see [Section 10.6.1](#).

10.3.4.2 RxError

When the ISP1705 has detected an error while receiving a USB packet, it deasserts NXT and sends an RXCMD with the RxError field set to logic 1. The received packet is no longer valid and must be dropped by the link.

10.3.4.3 HostDisconnect

HostDisconnect is encoded into the RxEvent field of the RXCMD. HostDisconnect is valid only when the ISP1705 is configured as a host (both DP\_PULLDOWN and DM\_PULLDOWN are set to logic 1), and indicates to the host controller when a peripheral is connected (0b) or disconnected (1b). The host controller must enable HostDisconnect by setting the HOST\_DISCON\_R and HOST\_DISCON\_F bits in the USB\_INTR\_EN\_R and USB\_INTR\_EN\_F registers, respectively. Changes in HostDisconnect will cause the PHY to send an RXCMD to the link with the updated value.

10.4 Register read and write operations

Figure 14 shows register read and write sequences. The ISP1705 supports immediate addressing and extended addressing register operations. Extended register addressing is optional for links. Note that register operations will be aborted if the ISP1705 asserts DIR during the operation. When a register operation is aborted, the link must retry until successful. For more information on register operations, refer to *UTMI+ Low Pin Interface (ULPI) Specification Rev. 1.1*.

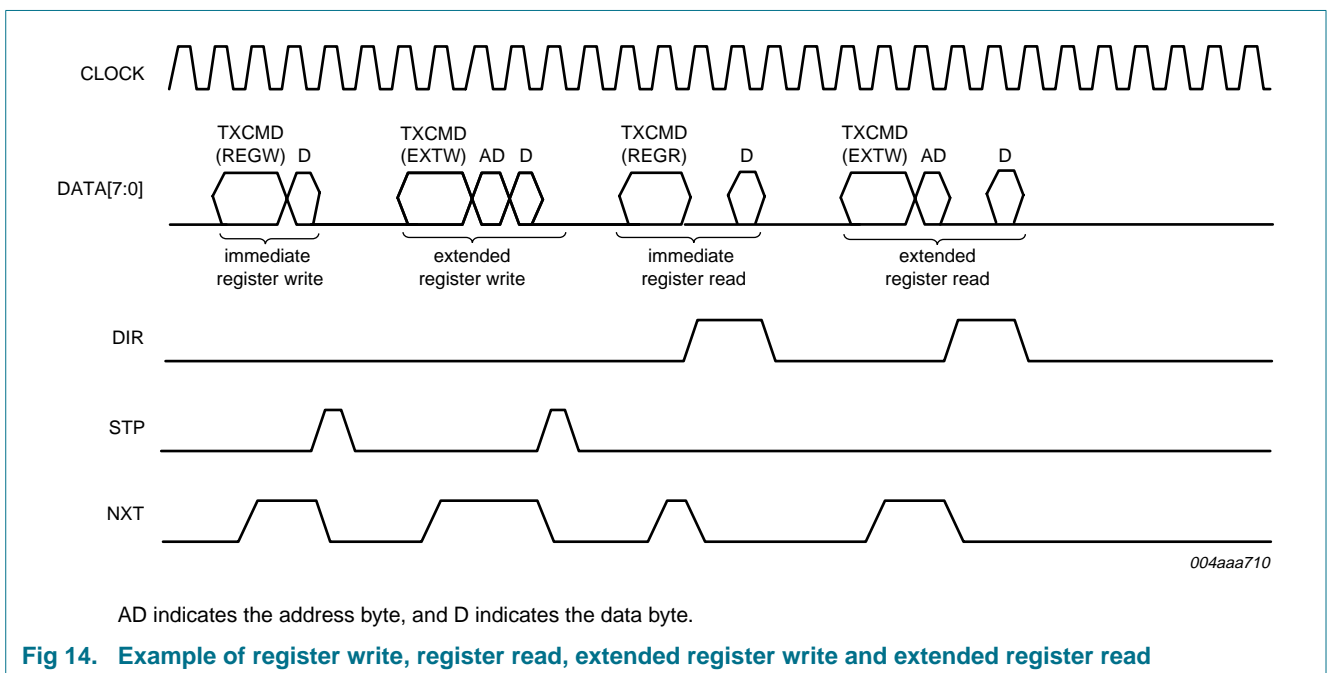

Fig 14. Example of register write, register read, extended register write and extended register read

10.5 USB reset and high-speed detection handshake (chirp)

Figure 15 shows the sequence of events for USB reset and high-speed detection handshake (chirp). The sequence is shown for hosts and peripherals. Figure 15 does not show all RXCMD updates, and timing is not to scale. The sequence is as follows:

1. USB reset: The host detects a peripheral attachment as low-speed if DM is HIGH and as full-speed if DP is HIGH. If a host detects a low-speed peripheral, it does not follow the remainder of this protocol. If a host detects a full-speed peripheral, it resets the peripheral by writing to the FUNC\_CTRL register (see [Section 11.5](#)) and setting XCVRSELECT[1:0] = 00b (high speed) and TERMSELECT = 0b that drives SE0 on the bus (DP and DM connected to ground through 45  $\Omega$ ). The host also sets OPMODE[1:0] = 10b for correct chirp transmit and receive. The start of SE0 is labeled t0.

**Remark:** To receive chirp signaling, the host must also consider the high-speed differential receiver output. The host controller must interpret LINESTATE as shown in [Table 19](#).

2. High-speed detection handshake (chirp)
  - a. Peripheral chirp: After detecting SE0 for no less than 2.5  $\mu$ s, if the peripheral is capable of high speed, it sets XCVRSELECT[1:0] to 00b (high speed) and OPMODE[1:0] to 10b (chirp). The peripheral immediately follows this with a TXCMD (NOPID), transmitting a Chirp K for no less than 1 ms and ending no more than 7 ms after reset time t0. If the peripheral is in low-power mode, it must wake up its clock within 5.6 ms, leaving 200  $\mu$ s for the link to start transmitting the Chirp K, and 1.2 ms for the Chirp K to complete (worst case with 10 % slow clock).
  - b. Host chirp: If the host does not detect the peripheral chirp, it must continue asserting SE0 until the end of reset. If the host detects the peripheral Chirp K for no less than 2.5  $\mu$ s, then no more than 100  $\mu$ s after the bus leaves the Chirp K state, the host sends a TXCMD (NOPID) with an alternating sequence of Chirp Ks and Js. Each Chirp K or Chirp J must last no less than 40  $\mu$ s and no longer than 60  $\mu$ s.
  - c. High speed idle: The peripheral must detect a minimum of Chirp K-J-K-J-K-J. Each Chirp K and Chirp J must be detected for at least 2.5  $\mu$ s. The peripheral sets TERMSELECT = 0b and OPMODE[1:0] = 00b after seeing the minimum chirp sequence. The peripheral is now in high-speed mode and sees !squelch (01b on LINESTATE). When the peripheral sees squelch (10b on LINESTATE), it knows that the host has completed chirp and waits for Hi-Speed USB traffic to begin. After transmitting the chirp sequence, the host changes OPMODE[1:0] to 00b and begins sending USB packets.

For more information, refer to *UTMI+ Low Pin Interface (ULPI) Specification Rev. 1.1*.

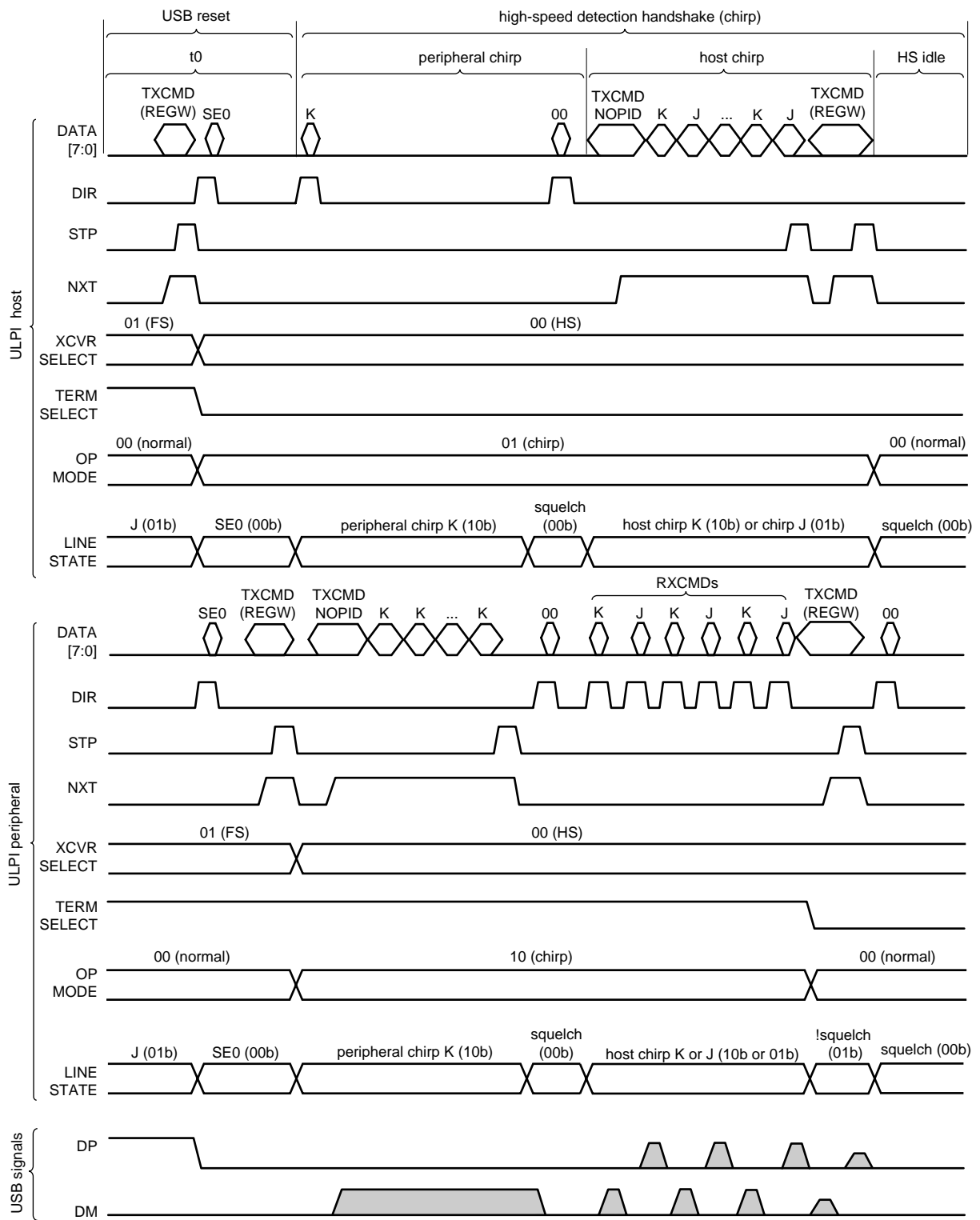

Fig 15. USB reset and high-speed detection handshake (chirp) sequence

### 10.6 USB packet transmit and receive

An example of a packet transmit and receive is shown in [Figure 16](#). For details on USB packets, refer to *UTMI+ Low Pin Interface (ULPI) Specification Rev. 1.1*.

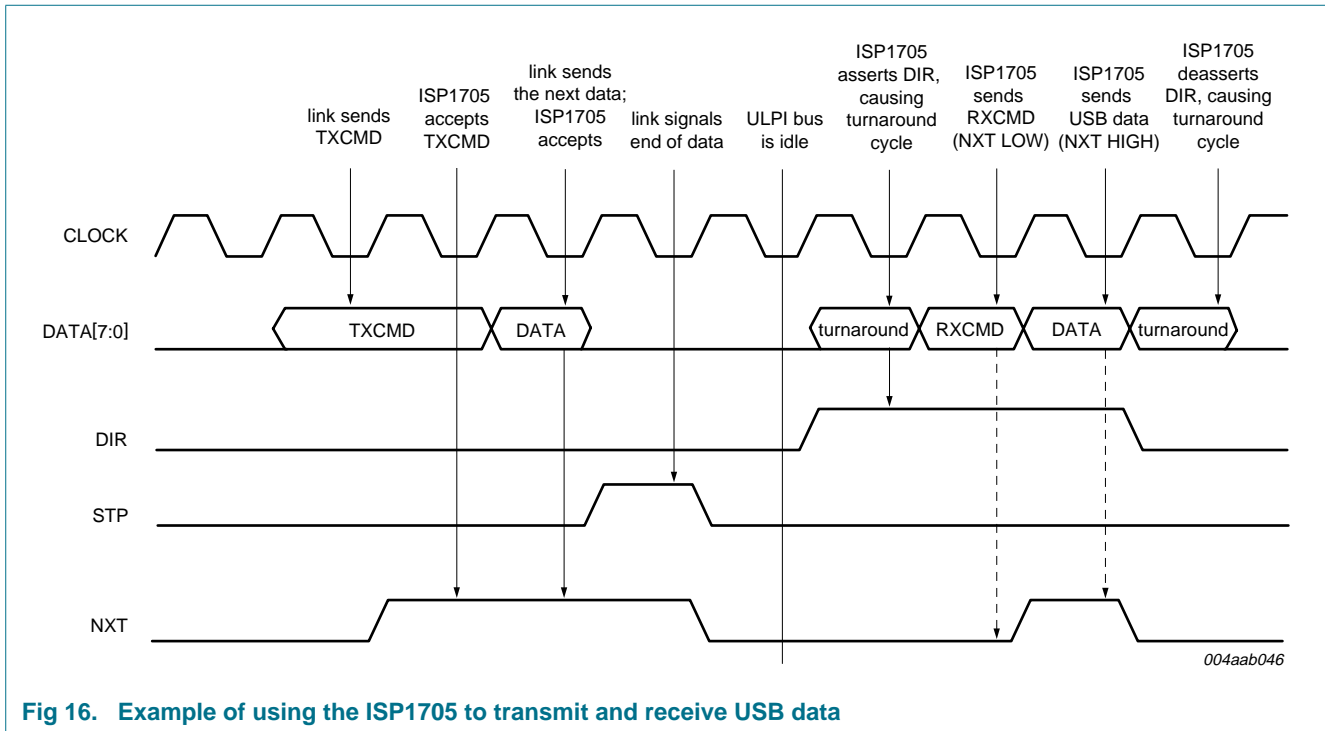

Fig 16. Example of using the ISP1705 to transmit and receive USB data

#### 10.6.1 USB packet timing

##### 10.6.1.1 ISP1705 pipeline delays

The ISP1705 delays (in clock cycles) are shown in [Table 23](#). For detailed description, refer to *UTMI+ Low Pin Interface (ULPI) Specification Rev. 1.1, Section 3.8.2.6.2*.

Table 23. PHY pipeline delays

Parameter name	High-speed PHY delay	Full-speed PHY delay	Low-speed PHY delay
RXCMD delay (J and K)	4	4	4
RXCMD delay (SE0)	4	4 to 6	16 to 18
TX start delay	1 to 2	6 to 10	74 to 75
TX end delay (packets)	3 to 4	not applicable	not applicable
TX end delay (SOF)	6 to 9	not applicable	not applicable
RX start delay	5 to 6	not applicable	not applicable
RX end delay	5 to 6	17 to 18	122 to 123

##### 10.6.1.2 Allowed link decision time

The amount of clock cycles allocated to the link to respond to a received packet and correctly receive back-to-back packets is given in [Table 24](#). Link designs must follow the values given in [Table 24](#) for correct USB system operation. Examples of high-speed packet sequences and timing are shown in [Figure 17](#) and [Figure 18](#). For details, refer to *UTMI+ Low Pin Interface (ULPI) Specification Rev. 1.1, Section 3.8.2.6.3*.



**Table 24. Link decision times**

Packet sequence	High-speed link delay	Full-speed link delay	Low-speed link delay	Definition
Transmit-Transmit (host only)	15 to 24	7 to 18	77 to 247	<p>Number of clock cycles a host link must wait before driving the TXCMD for the second packet.</p> <p>In high speed, the link starts counting from the assertion of STP for the first packet.</p> <p>In full speed, the link starts counting from the RXCMD, indicating LINESTATE has changed from SE0 to J for the first packet. The timing given ensures inter-packet delays of 2 bit times to 6.5 bit times.</p>
Receive-Transmit (host or peripheral)	1 to 14	7 to 18	77 to 247	<p>Number of clock cycles the link must wait before driving the TXCMD for the transmit packet.</p> <p>In high speed, the link starts counting from the end of the receive packet; deassertion of DIR or an RXCMD indicating RxActive is LOW.</p> <p>In full speed or low speed, the link starts counting from the RXCMD, indicating LINESTATE has changed from SE0 to J for the receive packet. The timing given ensures inter-packet delays of 2 bit times to 6.5 bit times.</p>
Receive-Receive (peripheral only)	1	1	1	Minimum number of clock cycles between consecutive receive packets. The link must be capable of receiving both packets.
Transmit-Receive (host or peripheral)	92	80	718	Host or peripheral transmits a packet and will time-out after this number of clock cycles if a response is not received. Any subsequent transmission can occur after this time.

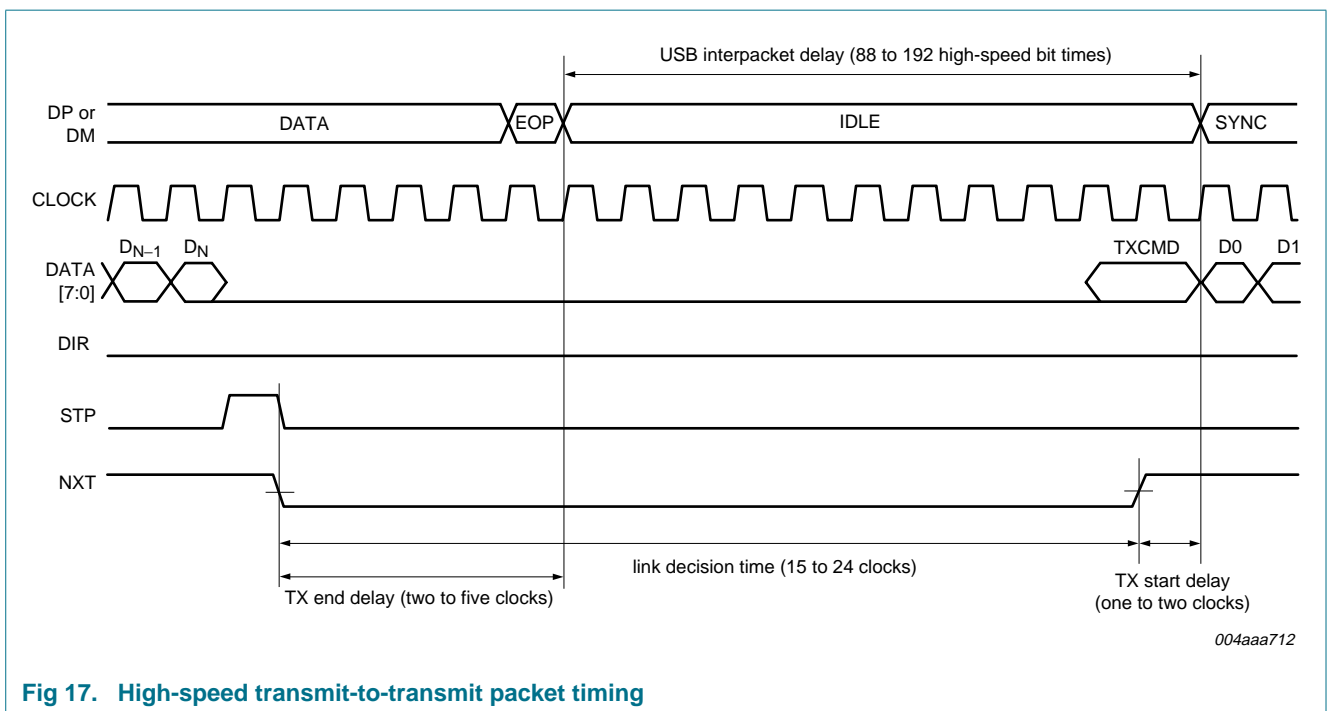

**Fig 17. High-speed transmit-to-transmit packet timing**

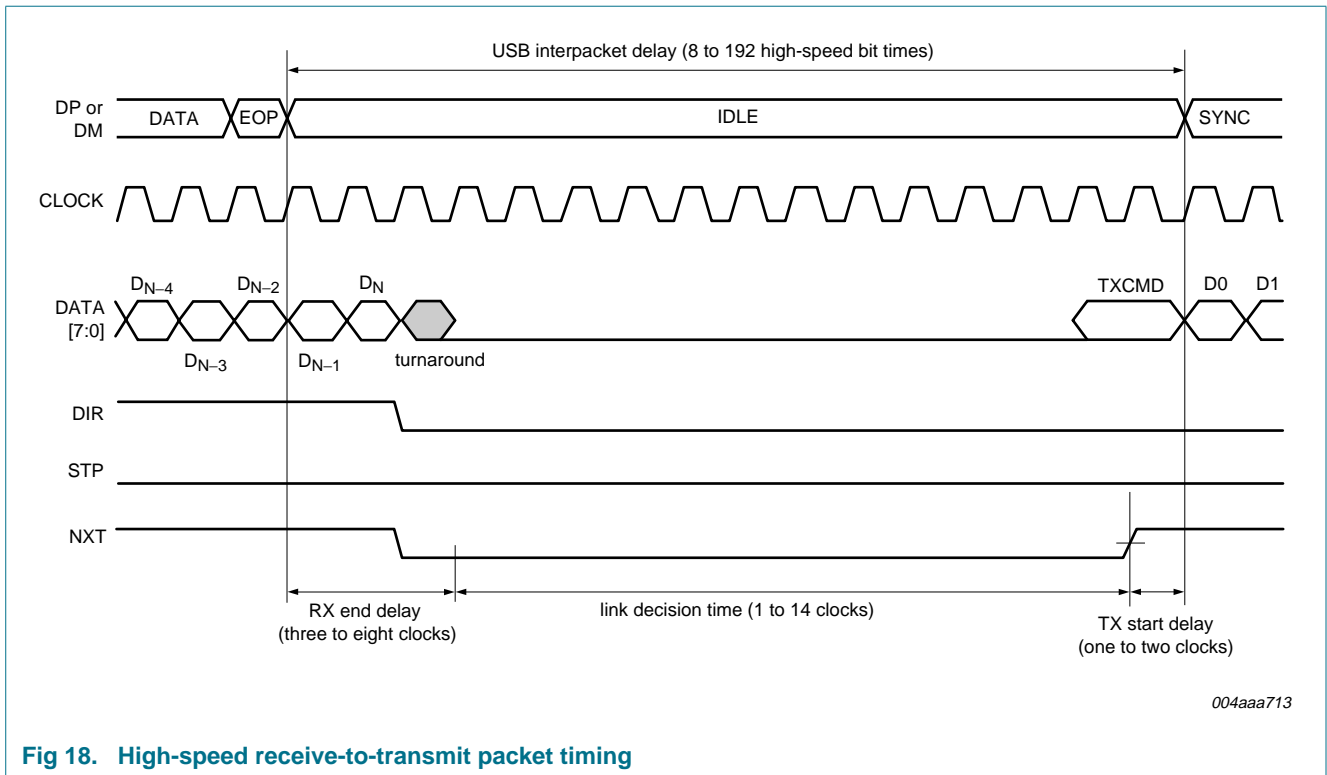
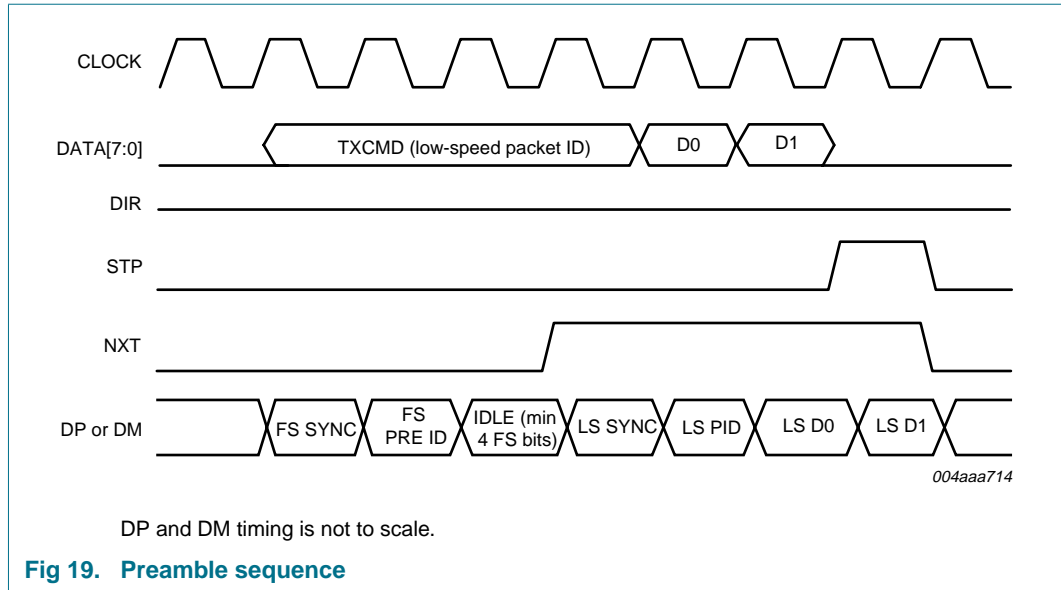

Fig 18. High-speed receive-to-transmit packet timing

### 10.7 Preamble

Preamble packets are headers to low-speed packets that must travel over a full-speed bus, between a host and a hub. To enter preamble mode, the link sets  $XCVRSELECT[1:0] = 11b$  in the `FUNC_CTRL` register (see [Section 11.5](#)). When in preamble mode, the ISP1705 operates just as in full-speed mode, and sends all data with the full-speed rise time and fall time. Whenever the link transmits a USB packet in preamble mode, the ISP1705 will automatically send a preamble header at full-speed bit rate before sending the link packet at low-speed bit rate. The ISP1705 will ensure a minimum gap of four full-speed bit times between the last bit of the full-speed PRE PID and the first bit of the low-speed packet SYNC. The ISP1705 will drive a J for at least one full-speed bit time after sending the PRE PID, after which the pull-up resistor can hold the J state on the bus. An example transmit packet is shown in [Figure 19](#).

In preamble mode, the ISP1705 can also receive low-speed packets from the full-speed bus.



## 10.8 USB suspend and resume

### 10.8.1 Full-speed or low-speed host-initiated suspend and resume

[Figure 20](#) illustrates how a host or a hub places a full-speed or low-speed peripheral into suspend and sometime later initiates resume signaling to wake-up the downstream peripheral. Note that [Figure 20](#) timing is not to scale, and does not show all RXCMD LINESTATE updates.

The sequence of events for a host and a peripheral, both with ISP1705, is as follows:

1. Idle: Initially, the host and the peripheral are idle. The host has its 15 kΩ pull-down resistors enabled (DP\_PULLDOWN and DM\_PULLDOWN are set to 1b) and 45 Ω terminations are disabled (TERMSELECT is set to 1b). The peripheral has the 1.5 kΩ pull-up resistor connected to DP for full speed or DM for low speed (TERMSELECT is set to 1b).
2. Suspend: When the peripheral sees no bus activity for 3 ms, it enters the suspend state. The peripheral link places the PHY into low-power mode by clearing the SUSPENDM bit in the FUNC\_CTRL register (see [Section 11.5](#)), causing the PHY to draw only suspend current. The host may or may not be powered down.
3. Resume K: When the host wants to wake up the peripheral, it sets OPMODE[1:0] to 10b and transmits a K for at least 20 ms. The peripheral link sees the resume K on LINESTATE, and asserts STP to wake up the PHY.
4. EOP: When STP is asserted, the ISP1705 on the host side automatically appends an EOP of two bits of SE0 at low-speed bit rate, followed by one bit of J. The ISP1705 on the host side knows to add the EOP because DP\_PULLDOWN and DM\_PULLDOWN are set to 1b for a host. After the EOP is completed, the host link sets OPMODE[1:0] to 00b for normal operation. The peripheral link sees the EOP and also resumes normal operation.

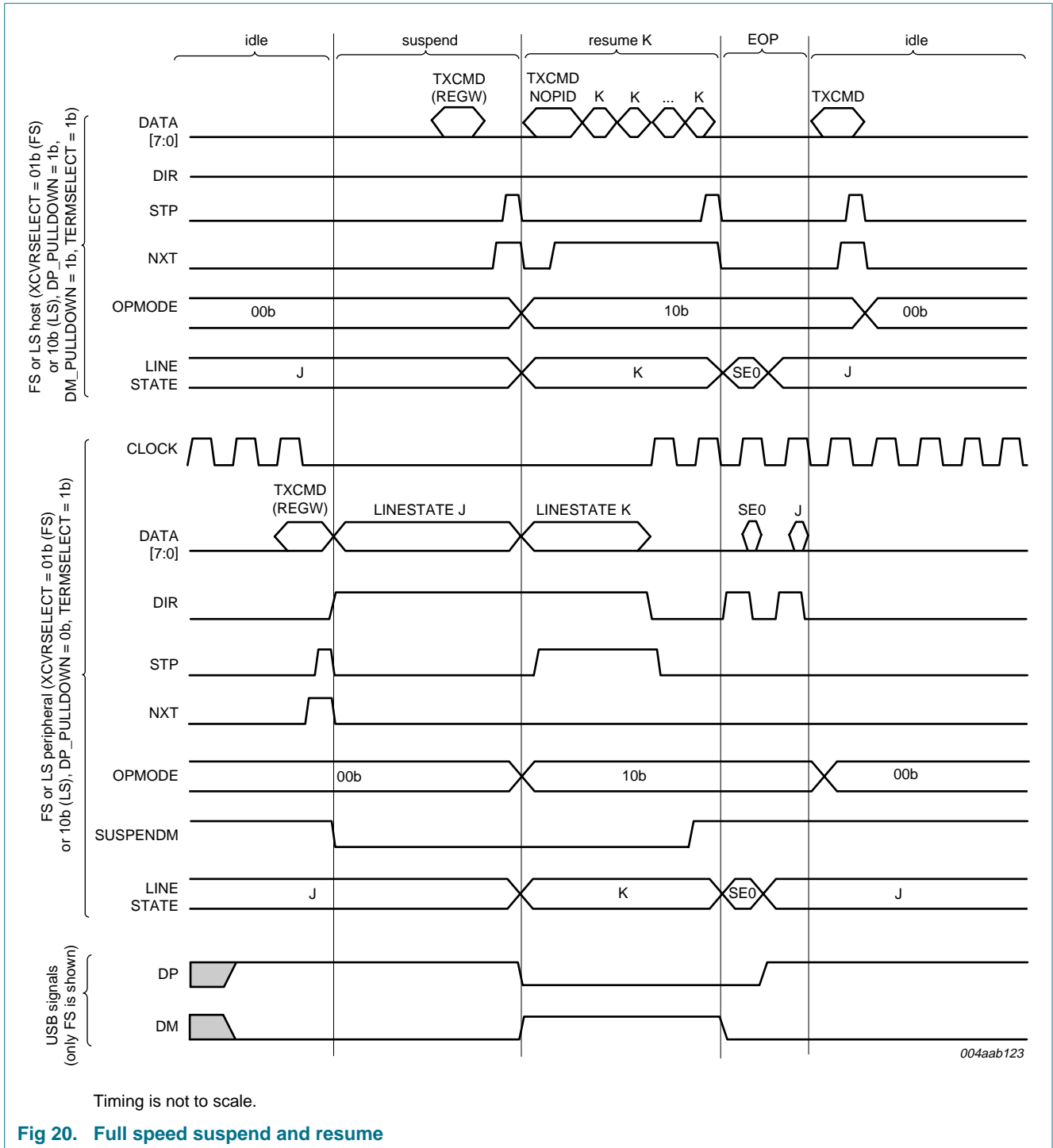

Fig 20. Full speed suspend and resume

### 10.8.2 High speed suspend and resume

Figure 21 illustrates how a host or a hub places a high-speed enabled peripheral into suspend and then initiates resume signaling. The high-speed peripheral will wake up and return to high-speed operations. Note that Figure 21 timing is not to scale, and does not show all RXCMD LINESTATE updates.

The sequence of events related to a host and a peripheral, both with ISP1705, is as follows:

1. High speed idle: Initially, the host and the peripheral are idle. The host has its 15 k $\Omega$  pull-down resistors enabled (DP\_PULLDOWN and DM\_PULLDOWN are set to 1b) and 45  $\Omega$  terminations enabled (TERMSELECT is set to 0b). The peripheral has its 45  $\Omega$  terminations enabled (TERMSELECT is set to 0b).
2. Full speed suspend: When the peripheral sees no bus activity for 3 ms, it enters the suspend state. The peripheral link places the ISP1705 into full-speed mode (XCVRSELECT is set to 01b), removes 45  $\Omega$  terminations, and enables the 1.5 k $\Omega$  pull-up resistor on DP (TERMSELECT is set to 1b). The peripheral link then places the ISP1705 into low-power mode by clearing SUSPENDM, causing the ISP1705 to draw only suspend current. The host also changes the ISP1705 to full speed, (XCVRSELECT is set to 01b), removes 45  $\Omega$  terminations (TERMSELECT is set to 1b), and then may or may not be powered down.
3. Resume K: When the host wants to wake up the peripheral, it sets OPMODE to 10b and transmits a full-speed K for at least 20 ms. The peripheral link sees the resume K (10b) on LINESTATE, and asserts STP to wake up the ISP1705.
4. High-speed traffic: The host link sets high speed (XCVRSELECT is set to 00b), and enables its 45  $\Omega$  terminations (TERMSELECT is set to 0b). The peripheral link sees SE0 on LINESTATE and also sets high speed (XCVRSELECT is set to 00b), and enables its 45  $\Omega$  terminations (TERMSELECT is set to 0b). The host link sets OPMODE to 00b for normal high-speed operation.

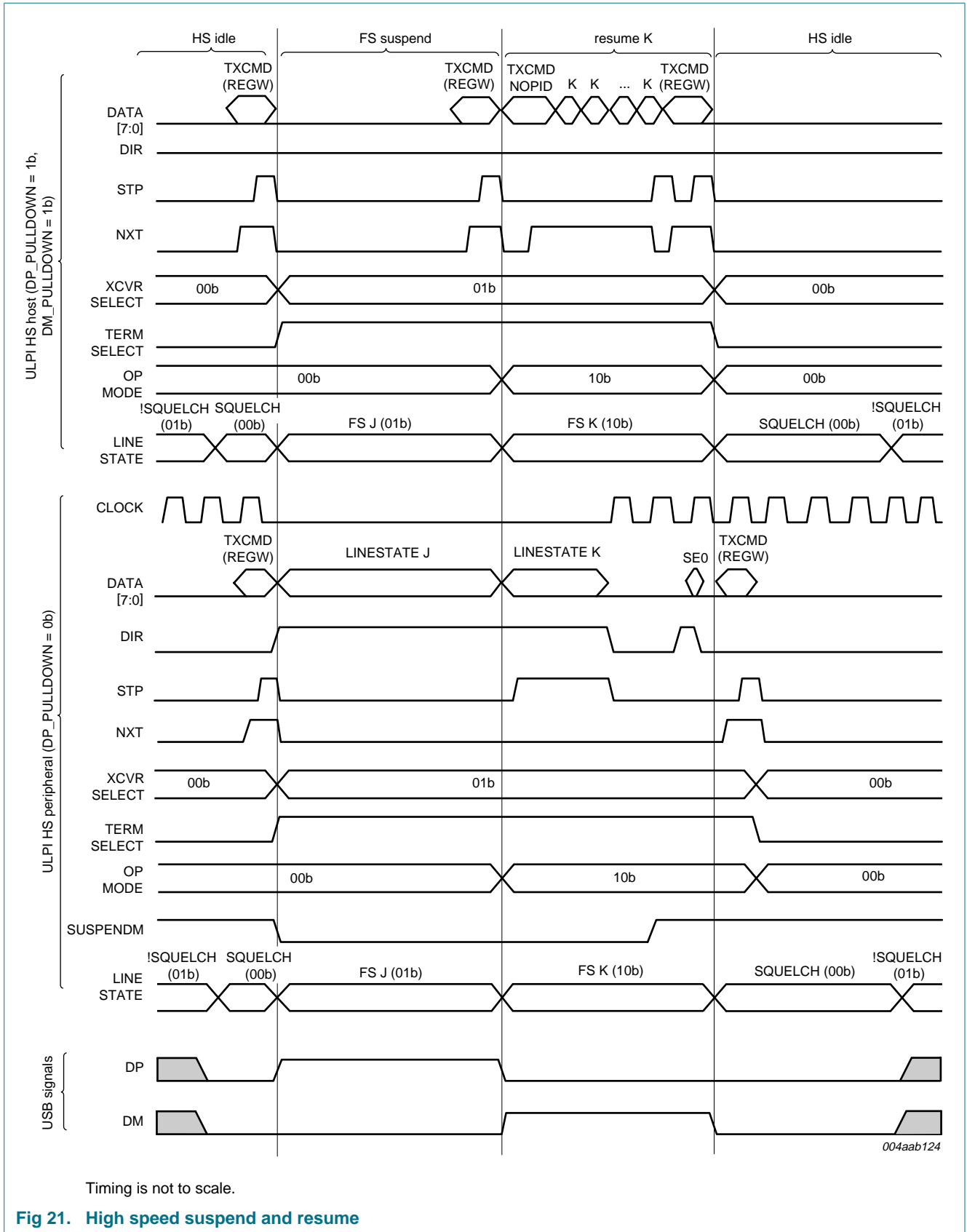

Fig 21. High speed suspend and resume

### 10.8.3 Remote wake-up

The ISP1705 supports peripherals that initiate remote wake-up resume. When placed into USB suspend, the peripheral link remembers at what speed it was originally operating. Depending on the original speed, the link follows one of the protocols detailed here. In [Figure 22](#), timing is not to scale, and not all RXCMD LINESTATE updates are shown.

The sequence of events related to a host and a peripheral, both with ISP1705, is as follows:

1. Both the host and the peripheral are assumed to be in low-power mode.
2. The peripheral begins remote wake-up by re-enabling its clock and setting its SUSPENDM bit to 1b.
3. The peripheral begins driving K on the bus to signal resume. Note that the peripheral link must assume that LINESTATE is K (01b) while transmitting because it will not receive any RXCMDs.
4. The host recognizes the resume, re-enables its clock and sets its SUSPENDM bit.
5. The host takes over resume driving within 1 ms of detecting the remote wake-up.
6. The peripheral stops driving resume.
7. The peripheral sees the host continuing to drive the resume.
8. The host stops driving resume and the ISP1705 automatically adds the EOP to the end of the resume. The peripheral recognizes the EOP as the end of resume.
9. Both the host and the peripheral revert to normal operation by writing 00b to OPMODE. If the host or the peripheral was previously in high-speed mode, it must revert to high speed before the SE0 of the EOP is completed. This can be achieved by writing XCVRSELECT[1:0] = 00b and TERMSELECT = 0b after LINESTATE indicates SE0.

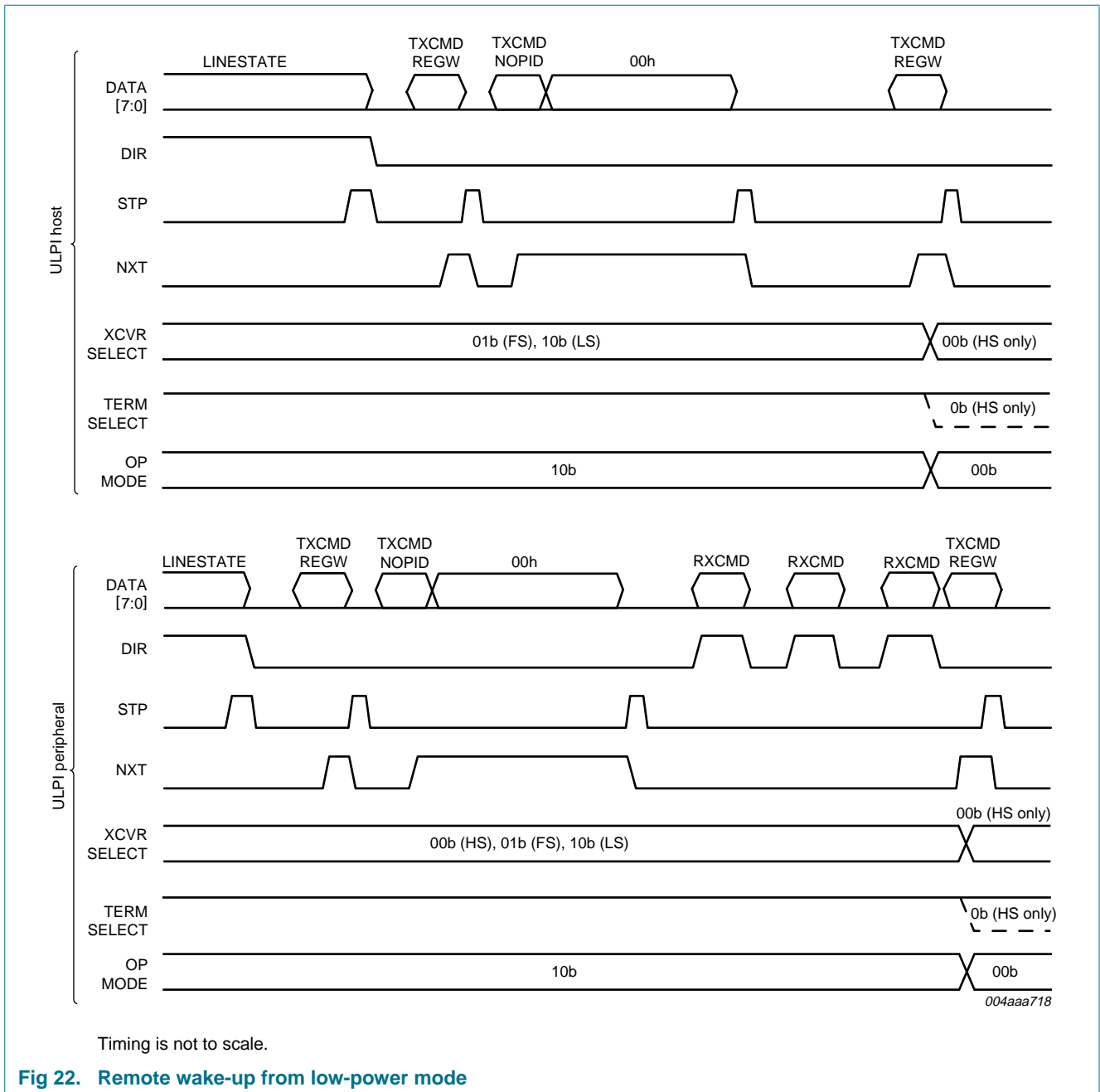

### 10.9 No automatic SYNC and EOP generation (optional)

This setting allows the link to turn off the automatic SYNC and EOP generation, and must be used for high-speed packets only. It is provided for backwards compatibility with legacy controllers that include SYNC and EOP bytes in the data payload when transmitting packets. The ISP1705 will not automatically generate SYNC and EOP patterns when OPMODE[1:0] is set to 11b. The ISP1705 will still NRZI encode data and perform bit stuffing. An example of a sequence is shown in Figure 23. The link must always send packets using the TXCMD (NOPID) type. The ISP1705 does not provide a mechanism to control bit stuffing in individual bytes, but will automatically turn off bit stuffing for EOP when STP is asserted with data set to FEh. If data is set to 00h when STP is asserted, the



PHY will not transmit any EOP. The ISP1705 will also detect if the PID byte is A5h, indicating an SOF packet, and automatically send a long EOP when STP is asserted. To transmit chirp and resume signaling, the link must set OPMODE to 10b.

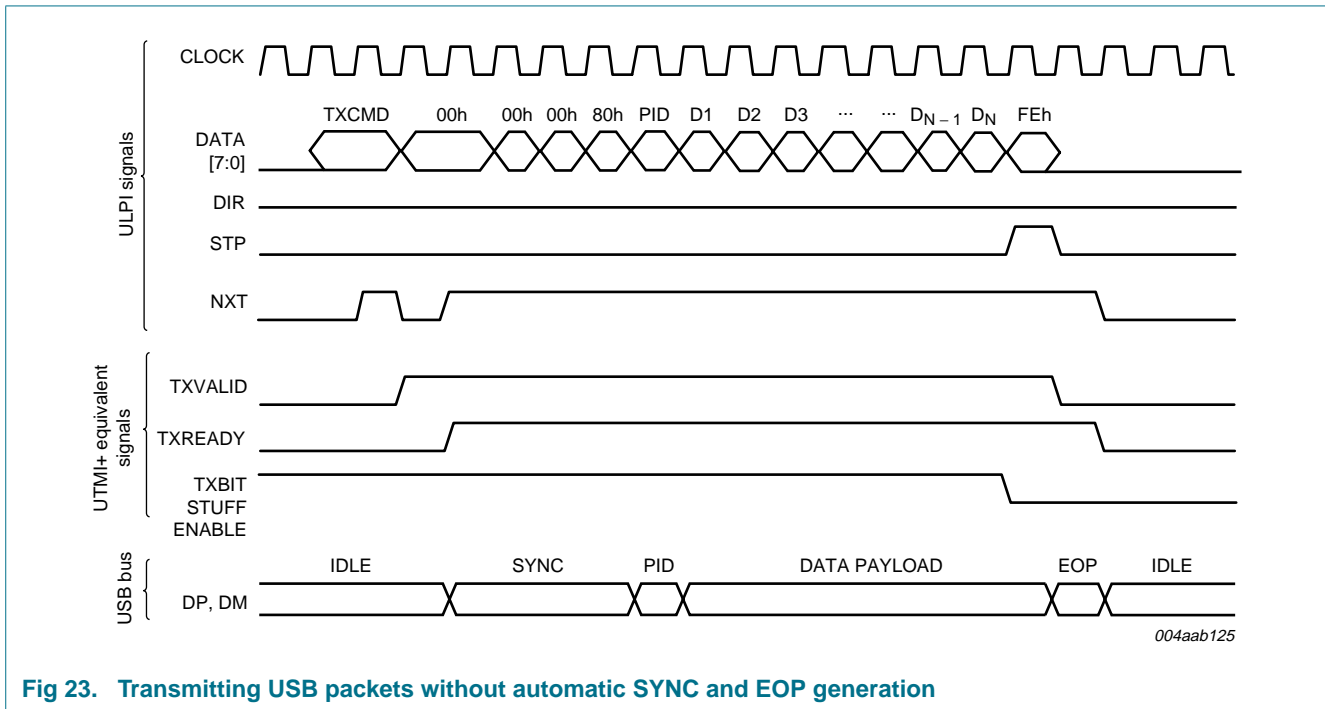

Fig 23. Transmitting USB packets without automatic SYNC and EOP generation

### 10.10 On-The-Go operations

On-The-Go (OTG) is a supplement to *Universal Serial Bus Specification Rev. 2.0* that allows a portable USB device to assume the role of a limited USB host by defining improvements, such as a small connector and low power. Non-portable devices, such as standard hosts and embedded hosts, can also benefit from OTG features.

The ISP1705 OTG PHY is designed to support all the tasks specified in the OTG supplement. The ISP1705 provides the front end analog support for Host Negotiation Protocol (HNP) and Session Request Protocol (SRP) for dual-role devices. The supporting components include:

- Voltage comparators
  - A\_VBUS\_VLD
  - SESS\_VLD (session valid, can be used for both A-session and B-session valid)
  - SESS\_END (session end)
- Pull-up and pull-down resistors on DP and DM
- ID detector indicates if micro-A or micro-B plug is inserted
- Charge and discharge resistors on V<sub>BUS</sub>

The following subsections describe how to use the ISP1705 OTG components.

### 10.10.1 OTG comparators

The ISP1705 provides comparators that conform to *On-The-Go Supplement to the USB 2.0 Specification Rev. 1.3* requirements of  $V_{A\_VBUS\_VLD}$ ,  $V_{A\_SESS\_VLD}$ ,  $V_{B\_SESS\_VLD}$  and  $V_{B\_SESS\_END}$ . In this data sheet,  $V_{A\_SESS\_VLD}$  and  $V_{B\_SESS\_VLD}$  are combined into  $V_{A\_SESS\_VLD}$ . Comparators are described in [Section 8.7.2](#). Changes in comparator values are communicated to the link by RXCMDs as described in [Section 10.3.2](#). Control over comparators is described in [Section 11.8](#) to [Section 11.11](#).

### 10.10.2 Pull-up and pull-down resistors

The USB resistors on DP and DM can be used to initiate data-line pulsing SRP. The link must set the required bus state using the mode settings in [Table 15](#).

### 10.10.3 ID detection

The ISP1705 provides an internal pull-up resistor to sense the state of the ID pin. The pull-up resistor must first be enabled by setting the ID\_PULLUP register bit to logic 1. If the state of pin ID has changed, the ISP1705 will send an RXCMD or interrupt to the link by time  $t_{ID}$ . If the link does not receive any RXCMD or interrupt by  $t_{ID}$ , then the ID state has not changed.

### 10.10.4 $V_{BUS}$ charge and discharge resistors

A pull-up resistor,  $R_{UP(VBUS)}$ , is provided to perform  $V_{BUS}$  pulsing SRP. A B-device is allowed to charge  $V_{BUS}$  above the session valid threshold to request the host to turn on the  $V_{BUS}$  voltage.

A pull-down resistor,  $R_{DN(VBUS)}$ , is provided for a B-device to discharge  $V_{BUS}$ . This is done whenever the A-device turns off the  $V_{BUS}$  voltage; the B-device can use the pull-down resistor to ensure  $V_{BUS}$  is below  $V_{B\_SESS\_END}$  before starting a session.

For details, refer to *On-The-Go Supplement to the USB 2.0 Specification Rev. 1.3*.

## 10.11 Serial modes

The ISP1705 supports both 6-pin serial mode and 3-pin serial mode, controlled by bits 6PIN\_FSLs\_SERIAL and 3PIN\_FSLs\_SERIAL of the INTF\_CTRL register (see [Section 11.6](#)). For details, refer to *UTMI+ Low Pin Interface (ULPI) Specification Rev. 1.1, Section 3.10*.

[Figure 24](#) and [Figure 25](#) provide examples of 6-pin serial mode and 3-pin serial mode, respectively.

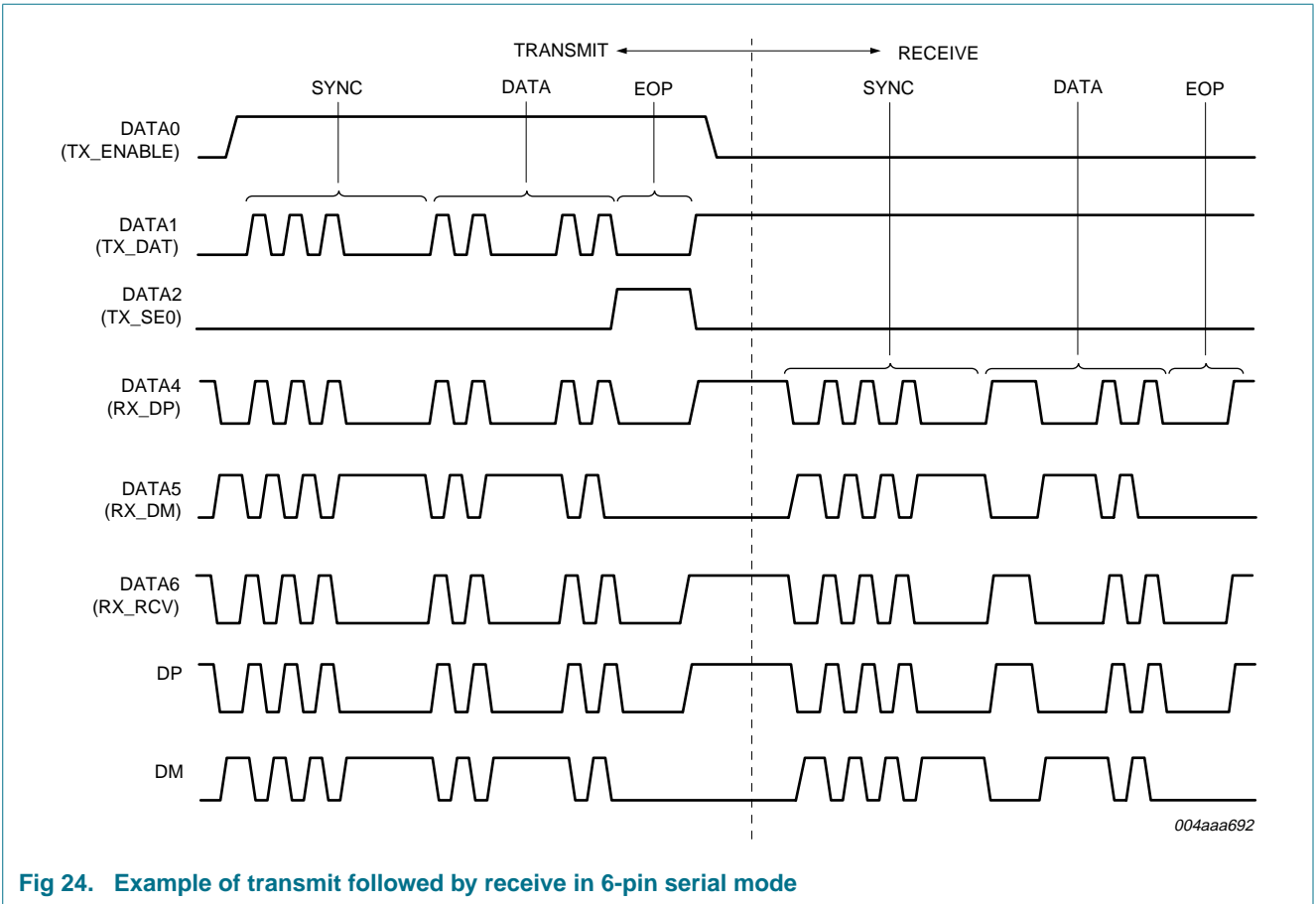

Fig 24. Example of transmit followed by receive in 6-pin serial mode

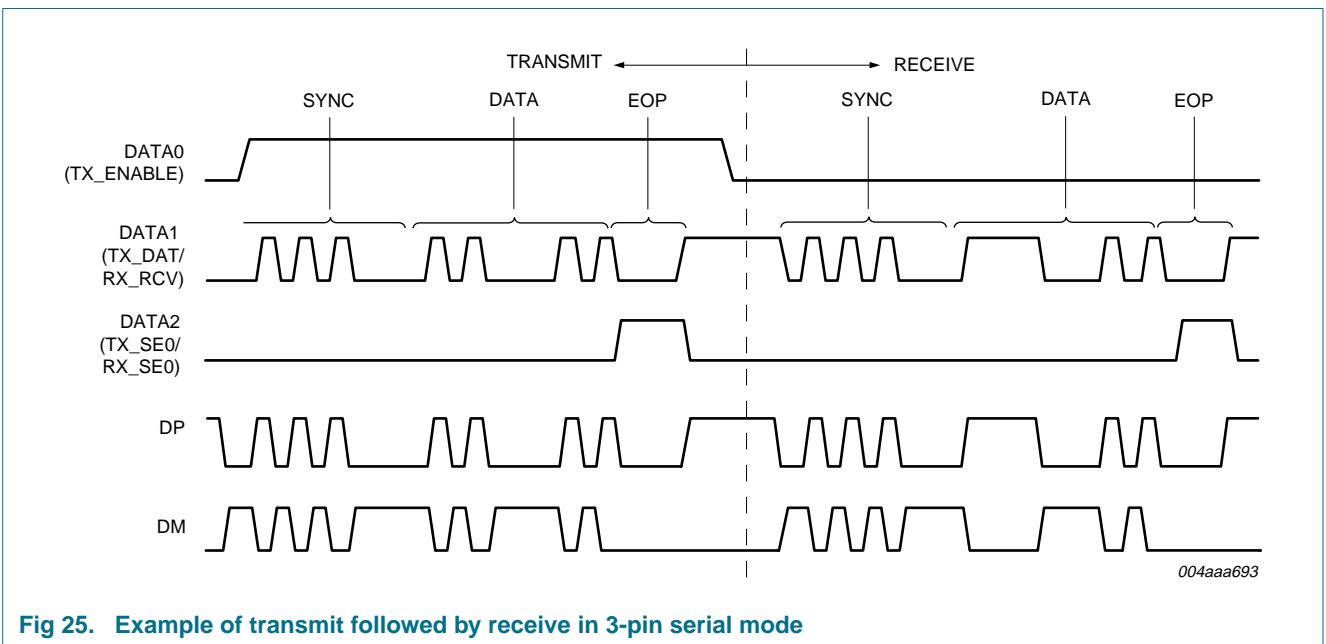

Fig 25. Example of transmit followed by receive in 3-pin serial mode

## 10.12 Aborting transfers

The ISP1705 supports aborting transfers on the ULPI bus. For details, refer to *UTMI+ Low Pin Interface (ULPI) Specification Rev. 1.1, Section 3.8.4*.

## 10.13 Avoiding contention on the ULPI data bus

Because the ULPI data bus is bidirectional, avoid situations in which both the link and the PHY simultaneously drive the data bus.

The following points must be considered while implementing the data bus drive control on the link.

After power-up and clock stabilization, default states are as follows:

- The ISP1705 drives DIR to LOW.
- The data bus is input to the ISP1705.
- The ULPI link data bus is output, with all data bus lines driven to LOW.

When the ISP1705 wants to take control of the data bus to initiate a data transfer, it changes the DIR state from LOW to HIGH.

At this point, the link must disable its output buffers. This must be as fast as possible so the link must use a combinational path from DIR.

The ISP1705 will not immediately enable its output buffers, but will delay the enabling of its buffers until the next clock edge, avoiding bus contention.

When the data transfer is no longer required by the ISP1705, it changes DIR from HIGH to LOW and starts to immediately turn off its output drivers. The link senses the change of DIR from HIGH to LOW, but delays enabling its output buffers for one CLOCK cycle, avoiding data bus contention.

## 11. Register map

Table 25. Register map

Field name	Size (bit)	Address (6 bit)				References
		R <sup>[1]</sup>	W <sup>[2]</sup>	S <sup>[3]</sup>	C <sup>[4]</sup>	
VENDOR_ID_LOW	8	00h	-	-	-	<a href="#">Section 11.1 on page 52</a>
VENDOR_ID_HIGH	8	01h	-	-	-	<a href="#">Section 11.2 on page 52</a>
PRODUCT_ID_LOW	8	02h	-	-	-	<a href="#">Section 11.3 on page 53</a>
PRODUCT_ID_HIGH	8	03h	-	-	-	<a href="#">Section 11.4 on page 53</a>
FUNC_CTRL	8	04h to 06h	04h	05h	06h	<a href="#">Section 11.5 on page 53</a>
INTF_CTRL	8	07h to 09h	07h	08h	09h	<a href="#">Section 11.6 on page 55</a>
OTG_CTRL	8	0Ah to 0Ch	0Ah	0Bh	0Ch	<a href="#">Section 11.7 on page 56</a>
USB_INTR_EN_R	8	0Dh to 0Fh	0Dh	0Eh	0Fh	<a href="#">Section 11.8 on page 58</a>
USB_INTR_EN_F	8	10h to 12h	10h	11h	12h	<a href="#">Section 11.9 on page 58</a>
USB_INTR_STAT	8	13h	-	-	-	<a href="#">Section 11.10 on page 59</a>
USB_INTR_L	8	14h	-	-	-	<a href="#">Section 11.11 on page 59</a>
DEBUG	8	15h	-	-	-	<a href="#">Section 11.12 on page 60</a>
SCRATCH	8	16h to 18h	16h	17h	18h	<a href="#">Section 11.13 on page 61</a>
CARKIT_CTRL	8	19h to 1Bh	19h	1Ah	1Bh	<a href="#">Section 11.14 on page 61</a>
Reserved	8	1Ch to 3Ch	-	-	-	-
PWR_CTRL	8	3Dh to 3Fh	3Dh	3Eh	3Fh	<a href="#">Section 11.15 on page 62</a>

- [1] Read (R): A register can be read. Read-only if this is the only mode given.
- [2] Write (W): The pattern on the data bus will be written over all bits of a register.
- [3] Set (S): The pattern on the data bus is OR-ed with and written to a register.
- [4] Clear (C): The pattern on the data bus is a mask. If a bit in the mask is set, then the corresponding register bit will be set to zero (cleared).

### 11.1 VENDOR\_ID\_LOW register

[Table 26](#) shows the bit description of the register.

Table 26. VENDOR\_ID\_LOW - Vendor ID low register (address R = 00h) bit description

Legend: \* reset value

Bit	Symbol	Access	Value	Description
7 to 0	VENDOR_ID_LOW[7:0]	R	CCh*	<b>Vendor ID low:</b> Lower byte of the NXP vendor ID supplied by USB-IF; fixed value of CCh

### 11.2 VENDOR\_ID\_HIGH register

[Table 27](#) shows the bit description of the register.

Table 27. VENDOR\_ID\_HIGH - Vendor ID high register (address R = 01h) bit description

Legend: \* reset value

Bit	Symbol	Access	Value	Description
7 to 0	VENDOR_ID_HIGH[7:0]	R	04h*	<b>Vendor ID high:</b> Upper byte of the NXP vendor ID supplied by USB-IF; fixed value of 04h

### 11.3 PRODUCT\_ID\_LOW register

The bit description of the register is given in [Table 28](#).

**Table 28. PRODUCT\_ID\_LOW - Product ID low register (address R = 02h) bit description**  
 Legend: \* reset value

Bit	Symbol	Access	Value	Description
7 to 0	PRODUCT_ID_LOW[7:0]	R	05h*	<b>Product ID low:</b> Lower byte of the NXP product ID number; fixed value of 05h

### 11.4 PRODUCT\_ID\_HIGH register

The bit description of the register is given in [Table 29](#).

**Table 29. PRODUCT\_ID\_HIGH - Product ID high register (address R = 03h) bit description**  
 Legend: \* reset value

Bit	Symbol	Access	Value	Description
7 to 0	PRODUCT_ID_HIGH[7:0]	R	17h*	<b>Product ID high:</b> Upper byte of the NXP product ID number; fixed value of 17h

### 11.5 FUNC\_CTRL register

This register controls UTMI function settings of the PHY. The bit allocation of the register is given in [Table 30](#).

**Table 30. FUNC\_CTRL - Function control register (address R = 04h to 06h, W = 04h, S = 05h, C = 06h) bit allocation**

Bit	7	6	5	4	3	2	1	0
<b>Symbol</b>	reserved	SUSPENDM	RESET	OPMODE[1:0]		TERM SELECT	XCVRSELECT[1:0]	
<b>Reset</b>	0	1	0	0	0	0	0	1
<b>Access</b>	R/W/S/C	R/W/S/C	R/W/S/C	R/W/S/C	R/W/S/C	R/W/S/C	R/W/S/C	R/W/S/C

**Table 31. FUNC\_CTRL - Function control register (address R = 04h to 06h, W = 04h, S = 05h, C = 06h) bit description**

Bit	Symbol	Description
7	-	reserved
6	SUSPENDM	<b>Suspend:</b> Active-LOW PHY suspend. Places the PHY into low-power mode. The PHY will power down all blocks, except the full-speed receiver, OTG comparators and ULPI interface pins. To come out of low-power mode, the link must assert STP. The PHY will automatically clear this bit when it exits low-power mode. <b>0b</b> — Low-power mode <b>1b</b> — Powered
5	RESET	<b>Reset:</b> Active-HIGH transceiver reset. After the link sets this bit, the PHY will assert DIR and reset the digital core. This does not reset the ULPI interface or the ULPI register set. When the reset is completed, the PHY will deassert DIR and automatically clear this bit, followed by an RXCMD update to the link. The link must wait for DIR to be deasserted before using the ULPI bus. <b>0b</b> — Do not reset <b>1b</b> — Reset

**Table 31. FUNC\_CTRL - Function control register (address R = 04h to 06h, W = 04h, S = 05h, C = 06h) bit description ...continued**

Bit	Symbol	Description
4 to 3	OPMODE[1:0]	<p><b>Operation mode:</b> Selects the required bit-encoding style during transmit.</p> <p><b>00b</b> — Normal operation</p> <p><b>01b</b> — Non-driving</p> <p><b>10b</b> — Disable bit-stuffing and NRZI encoding</p> <p><b>11b</b> — Do not automatically add SYNC and EOP when transmitting; must be used only for high-speed packets</p>
2	TERMSELECT	<p><b>Termination select:</b> Controls the internal 1.5 k<math>\Omega</math> full-speed pull-up resistor and 45 <math>\Omega</math> high-speed terminations. Control over bus resistors changes, depending on XCVRSELECT[1:0], OPMODE[1:0], DP_PULLDOWN and DM_PULLDOWN, as shown in <a href="#">Table 15</a>.</p>
1 to 0	XCVRSELECT[1:0]	<p><b>Transceiver select:</b> Selects the required transceiver speed.</p> <p><b>00b</b> — Enable the high-speed transceiver</p> <p><b>01b</b> — Enable the full-speed transceiver</p> <p><b>10b</b> — Enable the low-speed transceiver</p> <p><b>11b</b> — Enable the full-speed transceiver for low-speed packets (full-speed preamble is automatically prefixed)</p>

### 11.6 INTF\_CTRL register

The INTF\_CTRL register enables alternative interfaces. All of these modes are optional features provided for legacy link cores. Setting more than one of these fields results in undefined behavior. [Table 32](#) provides the bit allocation of the register.

**Table 32. INTF\_CTRL - Interface control register (address R = 07h to 09h, W = 07h, S = 08h, C = 09h) bit allocation**

Bit	7	6	5	4	3	2	1	0
Symbol	INTF_PROT_DIS	IND_PASS_THRU	IND_COMPL	reserved	CLOCK_SUSPENDM	CARKIT_MODE	3PIN_FSL_SERIAL	6PIN_FSL_SERIAL
Reset	0	0	0	0	0	0	0	0
Access	R/W/S/C	R/W/S/C	R/W/S/C	R/W/S/C	R/W/S/C	R/W/S/C	R/W/S/C	R/W/S/C

**Table 33. INTF\_CTRL - Interface control register (address R = 07h to 09h, W = 07h, S = 08h, C = 09h) bit description**

Bit	Symbol	Description
7	INTF_PROT_DIS	<p><b>Interface protect disable:</b> Controls circuitry built into the ISP1705 to protect the ULPI interface when the link 3-states STP and DATA[7:0]. When this bit is enabled, the ISP1705 will automatically detect when the link stops driving STP.</p> <p><b>0b</b> — Enables the interface protect circuit. The ISP1705 attaches a weak pull-up resistor on STP. If STP is unexpectedly HIGH, the ISP1705 attaches weak pull-down resistors on DATA[7:0], protecting data inputs</p> <p><b>1b</b> — Disables the interface protect circuit, detaches weak pull-down resistors on DATA[7:0], and a weak pull-up resistor on STP</p>
6	IND_PASSTHRU	<p><b>Indicator pass-through:</b> Controls whether the complement output is qualified with the internal A_VBUS_VLD comparator before being used in the V<sub>BUS</sub> state in RXCMD.</p> <p><b>0b</b> — The complement output signal is qualified with the internal A_VBUS_VLD comparator</p> <p><b>1b</b> — The complement output signal is not qualified with the internal A_VBUS_VLD comparator</p>
5	IND_COMPL	<p><b>Indicator complement:</b> Informs the PHY to invert the FAULT input signal, generating the complement output.</p> <p><b>0b</b> — The ISP1705 will not invert the FAULT signal</p> <p><b>1b</b> — The ISP1705 will invert the FAULT signal</p>
4	-	reserved
3	CLOCK_SUSPENDM	<p><b>Clock suspend:</b> Active-LOW clock suspend.</p> <p>Powers down the internal clock circuitry only. By default, the clock will not be powered in 6-pin serial mode or 3-pin serial mode.</p> <p>Valid only in 6-pin serial mode and 3-pin serial mode. Valid only when SUSPENDM is set to logic 1, otherwise this bit is ignored.</p> <p><b>0b</b> — Clock will not be powered in 3-pin or 6-pin serial mode or UART mode</p> <p><b>1b</b> — Clock will be powered in 3-pin and 6-pin serial mode or UART mode</p>



**Table 33. INTF\_CTRL - Interface control register (address R = 07h to 09h, W = 07h, S = 08h, C = 09h) bit description ...continued**

Bit	Symbol	Description
2	CARKIT_MODE	<p><b>Carkit mode:</b> Changes the ULPI interface to the carkit interface (UART mode). Bits TXD_EN and RXD_EN in the CARKIT_CTRL register (see <a href="#">Section 11.14</a>) must change as well. The PHY must automatically clear this bit when carkit mode is exited.</p> <p><b>0b</b> — Disable carkit mode  <b>1b</b> — Enable carkit mode</p>
1	3PIN_FSLT_SERIAL	<p><b>3-pin full-speed low-speed serial mode:</b> Changes the ULPI interface to a 3-bit serial interface. The ISP1705 will automatically clear this bit when 3-pin serial mode is exited.</p> <p><b>0b</b> — Full-speed or low-speed packets are sent using the parallel interface  <b>1b</b> — Full-speed or low-speed packets are sent using the 3-pin serial interface</p>
0	6PIN_FSLT_SERIAL	<p><b>6-pin full-speed low-speed serial mode:</b> Changes the ULPI interface to a 6-bit serial interface. The ISP1705 will automatically clear this bit when 6-pin serial mode is exited.</p> <p><b>0b</b> — Full-speed or low-speed packets are sent using the parallel interface  <b>1b</b> — Full-speed or low-speed packets are sent using the 6-pin serial interface</p>

### 11.7 OTG\_CTRL register

This register controls various OTG functions of the ISP1705. The bit allocation of the OTG\_CTRL register is given in [Table 34](#).

**Table 34. OTG\_CTRL - OTG control register (address R = 0Ah to 0Ch, W = 0Ah, S = 0Bh, C = 0Ch) bit allocation**

Bit	7	6	5	4	3	2	1	0
<b>Symbol</b>	USE_EXT_VBUS_IND	DRV_VBUS_EXT	reserved	CHRG_VBUS	DISCHRG_VBUS	DM_PULL_DOWN	DP_PULL_DOWN	ID_PULL_UP <sup>[1]</sup>
<b>Reset</b>	0	0	0	0	0	1	1	0
<b>Access</b>	R/W/S/C	R/W/S/C	R/W/S/C	R/W/S/C	R/W/S/C	R/W/S/C	R/W/S/C	R/W/S/C

[1] A weak pull-up, which can detect ID correctly, is present when the ID\_PULLUP bit is disabled. It is, however, mandatory that the link enables ID\_PULLUP.

**Table 35. OTG\_CTRL - OTG control register (address R = 0Ah to 0Ch, W = 0Ah, S = 0Bh, C = 0Ch) bit description**

Bit	Symbol	Description
7	USE_EXT_VBUS_IND	<p><b>Use external V<sub>BUS</sub> indicator:</b> Informs the PHY to use an external V<sub>BUS</sub> overcurrent indicator.</p> <p><b>0b</b> — Use the internal OTG comparator</p> <p><b>1b</b> — Use the external V<sub>BUS</sub> valid indicator signal input from the FAULT pin</p>
6	DRV_VBUS_EXT	<p><b>Drive V<sub>BUS</sub> external:</b> Controls the external charge pump or 5 V supply by the PSW_N pin.</p> <p><b>0b</b> — PSW_N is HIGH</p> <p><b>1b</b> — PSW_N to LOW</p>
5	reserved	-
4	CHRG_VBUS	<p><b>Charge V<sub>BUS</sub>:</b> Charges V<sub>BUS</sub> through a resistor. Used for the V<sub>BUS</sub> pulsing of SRP. The link must first check that V<sub>BUS</sub> is discharged (see bit DISCHRG_VBUS), and that both the DP and DM data lines have been LOW (SE0) for 2 ms.</p> <p><b>0b</b> — Do not charge V<sub>BUS</sub></p> <p><b>1b</b> — Charge V<sub>BUS</sub></p>
3	DISCHRG_VBUS	<p><b>Discharge V<sub>BUS</sub>:</b> Discharges V<sub>BUS</sub> through a resistor. If the link sets this bit to logic 1, it waits for an RXCMD indicating that SESS_END has changed from logic 0 to logic 1, and then resets this bit to logic 0 to stop the discharge.</p> <p><b>0b</b> — Do not discharge V<sub>BUS</sub></p> <p><b>1b</b> — Discharge V<sub>BUS</sub></p>
2	DM_PULLDOWN	<p><b>DM pull down:</b> Enables the 15 kΩ pull-down resistor on DM.</p> <p><b>0b</b> — pull-down resistor is not connected to DM</p> <p><b>1b</b> — pull-down resistor is connected to DM</p>
1	DP_PULLDOWN	<p><b>DP pull down:</b> Enables the 15 kΩ pull-down resistor on DP.</p> <p><b>0b</b> — Pull-down resistor is not connected to DP</p> <p><b>1b</b> — Pull-down resistor is connected to DP</p>
0	ID_PULLUP	<p><b>ID pull up:</b> Connects a pull-up to the ID line and enables sampling of the ID level. Disabling the ID line sampler will reduce the PHY power consumption.</p> <p><b>0b</b> — Disable sampling of the ID line</p> <p><b>1b</b> — Enable sampling of the ID line</p>

### 11.8 USB\_INTR\_EN\_R register

The bits in this register enable interrupts and RXCMDs to be sent when the corresponding bits in the USB\_INTR\_STAT register change from logic 0 to logic 1. By default, all transitions are enabled. [Table 36](#) shows the bit allocation of the register.

**Table 36. USB\_INTR\_EN\_R - USB interrupt enable rising register (address R = 0Dh to 0Fh, W = 0Dh, S = 0Eh, C = 0Fh) bit allocation**

Bit	7	6	5	4	3	2	1	0
Symbol	reserved			ID_GND_R	SESS_END_R	SESS_VALID_R	VBUS_VALID_R	HOST_DISCON_R
Reset	0	0	0	1	1	1	1	1
Access	R/W/S/C	R/W/S/C	R/W/S/C	R/W/S/C	R/W/S/C	R/W/S/C	R/W/S/C	R/W/S/C

**Table 37. USB\_INTR\_EN\_R - USB interrupt enable rising register (address R = 0Dh to 0Fh, W = 0Dh, S = 0Eh, C = 0Fh) bit description**

Bit	Symbol	Description
7 to 5	-	reserved
4	ID_GND_R	<b>ID ground rise:</b> Enables interrupts and RXCMDs for logic 0 to logic 1 transitions on ID_GND
3	SESS_END_R	<b>Session end rise:</b> Enables interrupts and RXCMDs for logic 0 to logic 1 transitions on SESS_END
2	SESS_VALID_R	<b>Session valid rise:</b> Enables interrupts and RXCMDs for logic 0 to logic 1 transitions on SESS_VLD
1	VBUS_VALID_R	<b>V<sub>BUS</sub> valid rise:</b> Enables interrupts and RXCMDs for logic 0 to logic 1 transitions on A_VBUS_VLD
0	HOST_DISCON_R	<b>Host disconnect rise:</b> Enables interrupts and RXCMDs for logic 0 to logic 1 transitions on HOST_DISCON

### 11.9 USB\_INTR\_EN\_F register

The bits in this register enable interrupts and RXCMDs to be sent when the corresponding bits in the USB\_INTR\_STAT register change from logic 1 to logic 0. By default, all transitions are enabled. See [Table 38](#).

**Table 38. USB\_INTR\_EN\_F - USB interrupt enable falling register (address R = 10h to 12h, W = 10h, S = 11h, C = 12h) bit allocation**

Bit	7	6	5	4	3	2	1	0
Symbol	reserved			ID_GND_F	SESS_END_F	SESS_VALID_F	VBUS_VALID_F	HOST_DISCON_F
Reset	0	0	0	1	1	1	1	1
Access	R/W/S/C	R/W/S/C	R/W/S/C	R/W/S/C	R/W/S/C	R/W/S/C	R/W/S/C	R/W/S/C

**Table 39. USB\_INTR\_EN\_F - USB interrupt enable falling register (address R = 10h to 12h, W = 10h, S = 11h, C = 12h) bit description**

Bit	Symbol	Description
7 to 5	-	reserved
4	ID_GND_F	<b>ID ground fall:</b> Enables interrupts and RXCMDs for logic 1 to logic 0 transitions on ID_GND.
3	SESS_END_F	<b>Session end fall:</b> Enables interrupts and RXCMDs for logic 1 to logic 0 transitions on SESS_END.
2	SESS_VALID_F	<b>Session valid fall:</b> Enables interrupts and RXCMDs for logic 1 to logic 0 transitions on SESS_VLD.
1	VBUS_VALID_F	<b>V<sub>BUS</sub> valid fall:</b> Enables interrupts and RXCMDs for logic 1 to logic 0 transitions on A_VBUS_VLD.
0	HOST_DISCON_F	<b>Host disconnect fall:</b> Enables interrupts and RXCMDs for logic 1 to logic 0 transitions on HOST_DISCON.

### 11.10 USB\_INTR\_STAT register

This register (see [Table 40](#)) indicates the current value of the interrupt source signal.

**Table 40. USB\_INTR\_STAT - USB interrupt status register (address R = 13h) bit allocation**

Bit	7	6	5	4	3	2	1	0
<b>Symbol</b>	reserved			ID_GND	SESS_END	SESS_VALID	VBUS_VALID	HOST_DISCON
<b>Reset</b>	X	X	X	0	0	0	0	0
<b>Access</b>	R	R	R	R	R	R	R	R

**Table 41. USB\_INTR\_STAT - USB interrupt status register (address R = 13h) bit description**

Bit	Symbol	Description
7 to 5	-	reserved
4	ID_GND	<b>ID ground:</b> Reflects the current state of the ID detector circuit.
3	SESS_END	<b>Session end:</b> Reflects the current value of the session end voltage comparator.
2	SESS_VALID	<b>Session valid:</b> Reflects the current value of the session valid voltage comparator.
1	VBUS_VALID	<b>V<sub>BUS</sub> valid:</b> Reflects the current value of the V <sub>BUS</sub> valid voltage comparator.
0	HOST_DISCON	<b>Host disconnect:</b> Reflects the current value of the host disconnect detector.

### 11.11 USB\_INTR\_L register

The bits of the USB\_INTR\_L register are automatically set by the ISP1705 when an unmasked change occurs on the corresponding interrupt source signal. The ISP1705 will automatically clear all bits when the link reads this register, or when the PHY enters low-power mode.

**Remark:** It is optional for the link to read this register when the clock is running because all signal information will automatically be sent to the link through the RXCMD byte.

The bit allocation of this register is given in [Table 42](#).

**Table 42. USB\_INTR\_L - USB interrupt latch register (address R = 14h) bit allocation**

Bit	7	6	5	4	3	2	1	0
Symbol	reserved			ID_GND_L	SESS_END_L	SESS_VALID_L	VBUS_VALID_L	HOST_DISCON_L
Reset	0	0	0	0	0	0	0	0
Access	R	R	R	R	R	R	R	R

**Table 43. USB\_INTR\_L - USB interrupt latch register (address R = 14h) bit description**

Bit	Symbol	Description
7 to 5	reserved	-
4	ID_GND_L	<b>ID ground latch:</b> Automatically set when an unmasked event occurs on ID_GND. Cleared when this register is read.
3	SESS_END_L	<b>Session end latch:</b> Automatically set when an unmasked event occurs on SESS_END. Cleared when this register is read.
2	SESS_VALID_L	<b>Session valid latch:</b> Automatically set when an unmasked event occurs on SESS_VLD. Cleared when this register is read.
1	VBUS_VALID_L	<b>V<sub>BUS</sub> valid latch:</b> Automatically set when an unmasked event occurs on A_VBUS_VLD. Cleared when this register is read.
0	HOST_DISCON_L	<b>Host disconnect latch:</b> Automatically set when an unmasked event occurs on HOST_DISCON. Cleared when this register is read.

### 11.12 DEBUG register

The bit allocation of the DEBUG register is given in [Table 44](#). This register indicates the current value of signals useful for debugging.

**Table 44. DEBUG - Debug register (address R = 15h) bit allocation**

Bit	7	6	5	4	3	2	1	0
Symbol	reserved						LINE STATE1	LINE STATE0
Reset	0	0	0	0	0	0	0	0
Access	R	R	R	R	R	R	R	R

**Table 45. DEBUG - Debug register (address R = 15h) bit description**

Bit	Symbol	Description
7 to 2	-	reserved
1	LINESTATE1	<b>Line state 1:</b> Contains the current value of LINESTATE 1
0	LINESTATE0	<b>Line state 0:</b> Contains the current value of LINESTATE 0

### 11.13 SCRATCH register

This is a 1-byte empty register for testing purposes, see [Table 46](#).

**Table 46. SCRATCH - Scratch register (address R = 16h to 18h, W = 16h, S = 17h, C = 18h) bit description**

Bit	Symbol	Access	Value	Description
7 to 0	SCRATCH[7:0]	R/W/S/C	00h	<b>Scratch:</b> This is an empty register byte for testing purposes. Software can read, write, set and clear this register. The functionality of the PHY will not be affected.

### 11.14 CARKIT\_CTRL register

This register controls transparent UART mode. This register is only valid when the CARKIT\_MODE bit in the INTF\_CTRL register (see [Section 11.6](#)) is set. When entering UART mode, set the CARKIT\_MODE bit, and then set the TXD\_EN and RXD\_EN bits. After entering UART mode, the ULPI interface is not available. When exiting UART mode, assert the STP pin or perform a hardware reset using chip select.

For bit allocation, see [Table 47](#).

**Table 47. CARKIT\_CTRL - Carkit control register (address R = 19h to 1Bh, W = 19h, S = 1Ah, C = 1Bh) bit allocation**

Bit	7	6	5	4	3	2	1	0
<b>Symbol</b>	reserved				RXD_EN	TXD_EN	reserved	
<b>Reset</b>	0	0	0	0	0	0	0	0
<b>Access</b>	R/W/S/C	R/W/S/C	R/W/S/C	R/W/S/C	R/W/S/C	R/W/S/C	R/W/S/C	R/W/S/C

**Table 48. CARKIT\_CTRL - Carkit control register (address R = 19h to 1Bh, W = 19h, S = 1Ah, C = 1Bh) bit description**

Bit	Symbol	Description
7 to 4	-	reserved; the link must never write logic 1 to these bits
3	RXD_EN	<b>RXD enable:</b> Routes the UART RXD signal from the DP pin to the DATA1 pin. This bit will automatically be cleared when UART mode is exited.
2	TXD_EN	<b>TXD enable:</b> Routes the UART TXD signal from the DATA0 pin to the DM pin. This bit will automatically be cleared when UART mode is exited.
1 to 0	-	reserved; the link must never write logic 1 to these bits

### 11.15 PWR\_CTRL register

This vendor-specific register controls the power feature of the ISP1705. The bit allocation of the register is given in [Table 49](#).

**Table 49. PWR\_CTRL - Power control register (address R = 3Dh to 3Fh, W = 3Dh, S = 3Eh, C = 3Fh) bit allocation**

Bit	7	6	5	4	3	2	1	0
Symbol	reserved			DP_WKPU_EN	BVALID_FALL	BVALID_RISE	reserved	
Reset	0	0	0	0	0	0	0	0
Access	R/W/S/C	R/W/S/C	R/W/S/C	R/W/S/C	R/W/S/C	R/W/S/C	R/W/S/C	R/W/S/C

**Table 50. PWR\_CTRL - Power control register (address R = 3Dh to 3Fh, W = 3Dh, S = 3Eh, C = 3Fh) bit description**

Bit	Symbol	Description
7 to 5	-	reserved; the link must never write logic 1 to these bits
4	DP_WKPU_EN	<b>DP weak pull-up enable:</b> Enable the weak pull-up resistor on the DP pin ( $R_{weakUP(DP)}$ ) in synchronous mode when $V_{BUS}$ is above the $V_{A\_SESS\_VLD}$ threshold. Note that when the ISP1705 is in UART mode, the DP weak pull-up will be enabled, regardless of the value of this register bit. <b>0</b> — DP weak pull-up is disabled. <b>1</b> — DP weak pull-up is enabled when $V_{BUS} > V_{A\_SESS\_VLD}$ .
3	BVALID_FALL	<b>BVALID fall:</b> Enables RXCMDs for HIGH-to-LOW transitions on BVALID. When BVALID changes from HIGH to LOW, the ISP1705 will send an RXCMD to the link with the ALT_INT bit set to logic 1. This bit is optional and is not necessary for OTG devices. This bit is provided for debugging purposes. Disabled by default.
2	BVALID_RISE	<b>BVALID rise:</b> Enables RXCMDs for LOW-to-HIGH transitions on BVALID. When BVALID changes from LOW to HIGH, the ISP1705 will send an RXCMD to the link with the ALT_INT bit set to logic 1. This bit is optional and is not necessary for OTG devices. This bit is provided for debugging purposes. Disabled by default.
1 to 0	-	reserved; the link must never write logic 1 to these bits

## 12. Limiting values

**Table 51. Limiting values**

In accordance with the Absolute Maximum Rating System (IEC 60134).

Symbol	Parameter	Conditions	Min	Max	Unit
V <sub>CC</sub>	supply voltage		-0.5	+5.5	V
V <sub>CC(I/O)</sub>	input/output supply voltage		-0.5	+4.6	V
V <sub>I</sub>	input voltage	on pins PSW_N and FAULT	-0.5	+5.5	V
		on pins CLOCK, STP, DATA[7:0], CFG1, CFG2, RESET_N, CHIP_SEL and CHIP_SEL_N	-0.5	V <sub>CC(I/O)</sub> + 0.5	V
		on pins ID and CFG0	-0.5	+4.6	V
		on pin XTAL1	-0.5	+2.5	V
		on pins DP and DM	[1] -0.5	+4.6	V
		on pin V <sub>BUS</sub>	[2] -0.5	+5.5	V
V <sub>ESD</sub>	electrostatic discharge voltage	human body model (JESD22-A114D)	-2	+2	kV
		machine model (JESD22-A115-A)	-200	+200	V
		charged device model (JESD22-C101-C)	-500	+500	V
		IEC 61000-4-2 contact on pins DP and DM	[3] -8	+8	kV
I <sub>lu</sub>	latch-up current		-	100	mA
T <sub>stg</sub>	storage temperature		-60	+125	°C

- [1] The ISP1705 has been tested according to the additional requirements listed in *Universal Serial Bus Specification Rev. 2.0, Section 7.1.1*. The short circuit withstand test and the AC stress test were performed for 24 hours, and the ISP1705 was found to be fully operational after the test completed.
- [2] When an external series resistor is added to the V<sub>BUS</sub> pin, it can withstand higher voltages for longer periods of time because the resistor limits the current flowing into the V<sub>BUS</sub> pad. For example, with an external 1 kΩ resistor, V<sub>BUS</sub> can tolerate 10 V for at least 5 seconds. Actual performance may vary depending on the resistor used and whether other components are connected to V<sub>BUS</sub>.
- [3] The ISP1705 has been tested in-house according to the IEC 61000-4-2 standard on the DP and DM pins. It is recommended that customers perform their own ESD tests, depending on application requirements.

## 13. Recommended operating conditions

**Table 52. Recommended operating conditions**

Symbol	Parameter	Conditions	Min	Typ	Max	Unit
V <sub>CC</sub>	supply voltage		3.0	3.6	4.5	V
V <sub>CC(I/O)</sub>	input/output supply voltage		3.0	3.3	3.6	V
V <sub>I</sub>	input voltage	on pins PSW_N, FAULT and V <sub>BUS</sub>	0	-	5.25	V
		on pins CLOCK, STP, DATA[7:0], CFG1, CFG2, RESET_N, CHIP_SEL and CHIP_SEL_N	0	-	V <sub>CC(I/O)</sub>	V
		on pins DP, DM, ID and CFG0	0	-	3.6	V
		on pin XTAL1	0	-	1.95	V
T <sub>j</sub>	junction temperature		-40	-	+125	°C
T <sub>amb</sub>	ambient temperature		-40	+25	+85	°C



## 14. Static characteristics

**Table 53. Static characteristics: supply pins**

$V_{CC} = 3.0\text{ V to }4.5\text{ V}$ ;  $V_{CC(I/O)} = 3.0\text{ V to }3.6\text{ V}$ ;  $T_{amb} = -40\text{ }^{\circ}\text{C to }+85\text{ }^{\circ}\text{C}$ ; unless otherwise specified.  
 Typical values refer to  $V_{CC} = 3.6\text{ V}$ ;  $V_{CC(I/O)} = 3.3\text{ V}$ ;  $T_{amb} = +25\text{ }^{\circ}\text{C}$ ; unless otherwise specified.

Symbol	Parameter	Conditions	Min	Typ	Max	Unit	
$V_{POR(trip)}$	power-on reset trip voltage	on REG1V8 pin	0.95	-	1.5	V	
$I_{CC}$	supply current	Power-down mode ( $V_{CC(I/O)}$ is lost or chip select is non-active)	-	0.5	10	$\mu\text{A}$	
		full-speed transceiver; bus idle; no USB activity	-	13	-	mA	
		full-speed transceiver; 100 % transmission; no inter-packet delay	-	25.65	-	mA	
		high-speed transceiver; 100 % transmission; no inter-packet delay	-	55.30	-	mA	
		low-power mode (bit SUSPENDM is logic 0); $V_{BUS}$ valid detector disabled (bits VBUS_VALID_R and VBUS_VALID_F are cleared)					
		for host	-	70	100	$\mu\text{A}$	
		for peripheral	-	240	330	$\mu\text{A}$	
		UART mode; low-speed transceiver; idle	-	750	-	$\mu\text{A}$	
$I_{CC(I/O)(stat)}$	static supply current on pin $V_{CC(I/O)}$	Power-down mode (chip select is non-active)	-	-	10	$\mu\text{A}$	
		ULPI bus idle; 15 pF load on pin CLOCK	[1]	-	2	-	mA

[1] The actual value of  $I_{CC(I/O)}$  varies depending on the capacitance loading, interface voltage and bus activity. Use the value provided here only as a reference.

**Table 54. Static characteristics: digital pins**

Digital pins: CLOCK, DIR, STP, NXT, DATA[7:0], CHIP\_SEL\_N, CHIP\_SEL, CFG1, CFG2 and RESET\_N; unless otherwise specified.

$V_{CC} = 3.0\text{ V to }4.5\text{ V}$ ;  $V_{CC(I/O)} = 3.0\text{ V to }3.6\text{ V}$ ;  $T_{amb} = -40\text{ }^{\circ}\text{C to }+85\text{ }^{\circ}\text{C}$ ; unless otherwise specified.  
 Typical values refer to  $V_{CC} = 3.6\text{ V}$ ;  $V_{CC(I/O)} = 3.3\text{ V}$ ;  $T_{amb} = +25\text{ }^{\circ}\text{C}$ ; unless otherwise specified.

Symbol	Parameter	Conditions	Min	Typ	Max	Unit
<b>Input levels</b>						
$V_{IH}$	HIGH-level input voltage		$0.7V_{CC(I/O)}$	-	-	V
$V_{IL}$	LOW-level input voltage		-	-	$0.3V_{CC(I/O)}$	V
$I_{LI}$	input leakage current		-1	-	+1	$\mu\text{A}$
<b>Output levels</b>						
$V_{OH}$	HIGH-level output voltage	$I_{OL} = +2\text{ mA}$	$V_{CC(I/O)} - 0.4$	-	-	V

**Table 54. Static characteristics: digital pins ...continued**

Digital pins: CLOCK, DIR, STP, NXT, DATA[7:0], CHIP\_SEL\_N, CHIP\_SEL, CFG1, CFG2 and RESET\_N; unless otherwise specified.

$V_{CC} = 3.0\text{ V to }4.5\text{ V}$ ;  $V_{CC(I/O)} = 3.0\text{ V to }3.6\text{ V}$ ;  $T_{amb} = -40\text{ }^{\circ}\text{C to }+85\text{ }^{\circ}\text{C}$ ; unless otherwise specified.

Typical values refer to  $V_{CC} = 3.6\text{ V}$ ;  $V_{CC(I/O)} = 3.3\text{ V}$ ;  $T_{amb} = +25\text{ }^{\circ}\text{C}$ ; unless otherwise specified.

Symbol	Parameter	Conditions	Min	Typ	Max	Unit
$V_{OL}$	LOW-level output voltage	$I_{OH} = -2\text{ mA}$	-	-	0.4	V
$I_{OH}$	HIGH-level output current	$V_{OH} = V_{CC(I/O)} - 0.4\text{ V}$	8	-	-	mA
$I_{OL}$	LOW-level output current	$V_{OL} = 0.4\text{ V}$	8	-	-	mA
<b>Impedance</b>						
$Z_L$	load impedance		45	-	65	$\Omega$
<b>Pull-up and pull-down</b>						
$I_{pu}$	pull-up current	interface protect enabled; STP pin only; $V_I = 0\text{ V}$	-30	-50	-80	$\mu\text{A}$
		UART mode; DATA0 pin only	-30	-50	-80	$\mu\text{A}$
$I_{pd}$	pull-down current	interface protect enabled; DATA[7:0] pins only; $V_I = V_{CC(I/O)}$	25	50	95	$\mu\text{A}$
<b>Capacitance</b>						
$C_{in}$	input capacitance		-	-	2.9	pF

**Table 55. Static characteristics: digital input pin FAULT**

$V_{CC} = 3.0\text{ V to }4.5\text{ V}$ ;  $V_{CC(I/O)} = 3.0\text{ V to }3.6\text{ V}$ ;  $T_{amb} = -40\text{ }^{\circ}\text{C to }+85\text{ }^{\circ}\text{C}$ ; unless otherwise specified.

Symbol	Parameter	Conditions	Min	Typ	Max	Unit
$V_{IL}$	LOW-level input voltage		-	-	0.8	V
$V_{IH}$	HIGH-level input voltage		2.0	-	-	V
$I_{IL}$	LOW-level input current	$V_I = 0\text{ V}$	-1	-	-	$\mu\text{A}$
$I_{IH}$	HIGH-level input current	$V_I = 5.25\text{ V}$	-	-	1	$\mu\text{A}$

**Table 56. Static characteristics: digital output pin PSW\_N**

$V_{CC} = 3.0\text{ V to }4.5\text{ V}$ ;  $V_{CC(I/O)} = 3.0\text{ V to }3.6\text{ V}$ ;  $T_{amb} = -40\text{ }^{\circ}\text{C to }+85\text{ }^{\circ}\text{C}$ ; unless otherwise specified.

Symbol	Parameter	Conditions	Min	Typ	Max	Unit
$V_{OH}$	HIGH-level output voltage	external pull-up resistor connected	3.0 <sup>[1]</sup>	-	5.25	V
$V_{OL}$	LOW-level output voltage	$I_{OL} = -4\text{ mA}$	-	-	0.4	V
$I_{OH}$	HIGH-level output current	external pull-up resistor connected	-	-	1	$\mu\text{A}$
$I_{OL}$	LOW-level output current	$V_O = 0.4\text{ V}$	4.0	-	-	mA

[1] When  $V_{OH}$  is less than  $V_{O(REG3V3)}$ ,  $I_{CC}$  may increase because of the cross current.

**Table 57. Static characteristics: analog pins (DP, DM)**

$V_{CC} = 3.0\text{ V to }4.5\text{ V}$ ;  $V_{CC(I/O)} = 3.0\text{ V to }3.6\text{ V}$ ;  $T_{amb} = -40\text{ }^{\circ}\text{C to }+85\text{ }^{\circ}\text{C}$ ; unless otherwise specified.

Typical values refer to  $V_{CC} = 3.6\text{ V}$ ;  $V_{CC(I/O)} = 3.3\text{ V}$ ;  $T_{amb} = +25\text{ }^{\circ}\text{C}$ ; unless otherwise specified.

Symbol	Parameter	Conditions	Min	Typ	Max	Unit
<b>Original USB transceiver (full speed and low speed)</b>						
<b>Input levels (differential data receiver)</b>						
$V_{DI}$	differential input sensitivity voltage	$ V_{DP} - V_{DM} $	0.2	-	-	V

**Table 57. Static characteristics: analog pins (DP, DM) ...continued**

$V_{CC} = 3.0\text{ V to }4.5\text{ V}$ ;  $V_{CC(I/O)} = 3.0\text{ V to }3.6\text{ V}$ ;  $T_{amb} = -40\text{ }^{\circ}\text{C to }+85\text{ }^{\circ}\text{C}$ ; unless otherwise specified.

Typical values refer to  $V_{CC} = 3.6\text{ V}$ ;  $V_{CC(I/O)} = 3.3\text{ V}$ ;  $T_{amb} = +25\text{ }^{\circ}\text{C}$ ; unless otherwise specified.

Symbol	Parameter	Conditions	Min	Typ	Max	Unit
$V_{CM}$	differential common mode voltage range	includes $V_{DI}$ range	0.8	-	2.5	V
<b>Input levels (single-ended receivers)</b>						
$V_{IL}$	LOW-level input voltage		-	-	0.8	V
$V_{IH}$	HIGH-level input voltage		2.0	-	-	V
<b>Output levels</b>						
$V_{OL}$	LOW-level output voltage	pull-up on DP; $R_L = 1.5\text{ k}\Omega$ to 3.6 V	0.0	-	0.3	V
$V_{OH}$	HIGH-level output voltage	pull-down on pins DP and DM; $R_L = 15\text{ k}\Omega$ to GND	2.8	-	3.6	V
$V_{CRS}$	output signal crossover voltage	excluding the first transition from the idle state	1.3	-	2.0	V
<b>Termination</b>						
$V_{TERM}$	termination voltage for upstream facing port pull-up	for 1.5 k $\Omega$ pull-up resistor	3.0	-	3.6	V
<b>Resistance</b>						
$R_{UP(DP)}$	pull-up resistance on pin DP		1425	1500	1575	$\Omega$
$R_{weakUP(DP)}$	weak pull-up resistance on pin DP	bit DP_WKPU_EN = 1 and $V_{BUS} > V_{A\_SESS\_VLD}$	100	125	150	k $\Omega$
<b>Hi-Speed USB transceiver (HS)</b>						
<b>Input levels</b>						
$V_{HSSQ}$	high-speed squelch detection threshold voltage (differential signal amplitude)		100	-	150	mV
$V_{HSDSC}$	high-speed disconnect detection threshold voltage (differential signal amplitude)		525	-	625	mV
$V_{HSDI}$	high-speed differential input sensitivity	$ V_{DP} - V_{DM} $	300	-	-	mV
$V_{HSCM}$	high-speed data signaling common mode voltage range (guideline for receiver)	includes $V_{DI}$ range	-50	-	+500	mV
<b>Output levels</b>						
$V_{HSOI}$	high-speed idle level voltage		-10	-	+10	mV
$V_{HSOL}$	high-speed data signaling LOW-level voltage		-10	-	+10	mV
$V_{HSOH}$	high-speed data signaling HIGH-level voltage		360	-	440	mV
$V_{CHIRPJ}$	Chirp J level (differential voltage)		700	-	1100	mV
$V_{CHIRPK}$	Chirp K level (differential voltage)		-900	-	-500	mV
<b>Leakage current</b>						
$I_{LZ}$	off-state leakage current		-1.0	-	+1.0	$\mu\text{A}$
<b>Capacitance</b>						
$C_{in}$	input capacitance	pin to GND	-	-	5	pF

**Table 57. Static characteristics: analog pins (DP, DM) ...continued**

$V_{CC} = 3.0\text{ V to }4.5\text{ V}$ ;  $V_{CC(I/O)} = 3.0\text{ V to }3.6\text{ V}$ ;  $T_{amb} = -40\text{ }^{\circ}\text{C to }+85\text{ }^{\circ}\text{C}$ ; unless otherwise specified.  
 Typical values refer to  $V_{CC} = 3.6\text{ V}$ ;  $V_{CC(I/O)} = 3.3\text{ V}$ ;  $T_{amb} = +25\text{ }^{\circ}\text{C}$ ; unless otherwise specified.

Symbol	Parameter	Conditions	Min	Typ	Max	Unit
<b>Resistance</b>						
$R_{DN(DP)}$	pull-down resistance on pin DP		14.25	15	15.75	k $\Omega$
$R_{DN(DM)}$	pull-down resistance on pin DM		14.25	15	15.75	k $\Omega$
<b>Termination</b>						
$Z_{O(drv)(DP)}$	driver output impedance on pin DP	steady-state drive	40.5	45	49.5	$\Omega$
$Z_{O(drv)(DM)}$	driver output impedance on pin DM	steady-state drive	40.5	45	49.5	$\Omega$
$Z_{INP}$	input impedance exclusive of pull-up/pull-down (for low-/full-speed)		1	-	-	M $\Omega$
<b>UART mode</b>						
<b>Input levels</b>						
$V_{IL}$	LOW-level input voltage	pin DP	-	-	0.8	V
$V_{IH}$	HIGH-level input voltage	pin DP	2.35	-	-	V
<b>Output levels</b>						
$V_{OL}$	LOW-level output voltage	pin DM; $I_{OL} = -4\text{ mA}$	-	-	0.3	V
$V_{OH}$	HIGH-level output voltage	pin DM; $I_{OH} = +4\text{ mA}$	2.4	-	-	V

**Table 58. Static characteristics: analog pin  $V_{BUS}$**

$V_{CC} = 3.0\text{ V to }4.5\text{ V}$ ;  $V_{CC(I/O)} = 3.0\text{ V to }3.6\text{ V}$ ;  $T_{amb} = -40\text{ }^{\circ}\text{C to }+85\text{ }^{\circ}\text{C}$ ; unless otherwise specified.  
 Typical values refer to  $V_{CC} = 3.6\text{ V}$ ;  $V_{CC(I/O)} = 3.3\text{ V}$ ;  $T_{amb} = +25\text{ }^{\circ}\text{C}$ ; unless otherwise specified.

Symbol	Parameter	Conditions	Min	Typ	Max	Unit
<b>Comparators</b>						
$V_{A\_VBUS\_VLD}$	A-device $V_{BUS}$ valid voltage		4.4	-	4.75	V
$V_{A\_SESS\_VLD}$	A-device session valid voltage	for A-device and B-device	0.8	1.6	2.0	V
$V_{hys(A\_SESS\_VLD)}$	A-device session valid hysteresis voltage	for A-device and B-device	-	100	-	mV
$V_{B\_SESS\_END}$	B-device session end voltage		0.2	-	0.8	V
<b>Resistance</b>						
$R_{UP(VBUS)}$	pull-up resistance on pin $V_{BUS}$	connect to REG3V3 when $CHRG\_VBUS = 1$	281	680	-	$\Omega$
$R_{DN(VBUS)}$	pull-down resistance on pin $V_{BUS}$	connect to GND when $DISCHRG\_VBUS = 1$	656	1200	-	$\Omega$
$R_{I(idle)(VBUS)}$	idle input resistance on pin $V_{BUS}$	not in Power-down mode	75	90	100	k $\Omega$
		chip deasserted (Power-down mode)	40	-	100	k $\Omega$
		$V_{CC(I/O)}$ lost (Power-down mode)	140	-	220	k $\Omega$

**Table 59. Static characteristics: analog pin CFG0**

$V_{CC} = 3.0\text{ V to }4.5\text{ V}$ ;  $V_{CC(I/O)} = 3.0\text{ V to }3.6\text{ V}$ ;  $T_{amb} = -40\text{ }^{\circ}\text{C to }+85\text{ }^{\circ}\text{C}$ ; unless otherwise specified.

Symbol	Parameter	Conditions	Min	Typ	Max	Unit
<b>Input levels</b>						
$V_{IL}$	LOW-level input voltage		-	-	0.8	V
$V_{IH}$	HIGH-level input voltage		2.0	-	-	V
$I_{LI}$	input leakage current		-1	-	+1	$\mu\text{A}$

**Table 60. Static characteristics: ID detection circuit**

$V_{CC} = 3.0\text{ V to }4.5\text{ V}$ ;  $V_{CC(I/O)} = 3.0\text{ V to }3.6\text{ V}$ ;  $T_{amb} = -40\text{ }^{\circ}\text{C to }+85\text{ }^{\circ}\text{C}$ ; unless otherwise specified.

Typical values refer to  $V_{CC} = 3.6\text{ V}$ ;  $V_{CC(I/O)} = 3.3\text{ V}$ ;  $T_{amb} = +25\text{ }^{\circ}\text{C}$ ; unless otherwise specified.

Symbol	Parameter	Conditions	Min	Typ	Max	Unit
$t_{ID}$	ID detection time		50	-	-	ms
$V_{th(ID)}$	ID detector threshold voltage		1.0	-	2.0	V
$R_{UP(ID)}$	ID pull-up resistance	bit ID_PULLUP = 1	40	50	60	$\text{k}\Omega$
$R_{weakPU(ID)}$	weak pull-up resistance on pin ID	bit ID_PULLUP = 0	320	400	480	$\text{k}\Omega$
$V_{PU(ID)}$	pull-up voltage on pin ID		3.0	3.3	3.6	V

**Table 61. Static characteristics: resistor reference**

$V_{CC} = 3.0\text{ V to }4.5\text{ V}$ ;  $V_{CC(I/O)} = 3.0\text{ V to }3.6\text{ V}$ ;  $T_{amb} = -40\text{ }^{\circ}\text{C to }+85\text{ }^{\circ}\text{C}$ ; unless otherwise specified.

$SUSPENDM = HIGH$ .

Typical values refer to  $V_{CC} = 3.6\text{ V}$ ;  $V_{CC(I/O)} = 3.3\text{ V}$ ;  $T_{amb} = +25\text{ }^{\circ}\text{C}$ ; unless otherwise specified.

Symbol	Parameter	Conditions	Min	Typ	Max	Unit
$V_{O(RREF)}$	output voltage on pin RREF		-	1.22	-	V

**Table 62. Static characteristics: regulator**

$V_{CC} = 3.0\text{ V to }4.5\text{ V}$ ;  $V_{CC(I/O)} = 3.0\text{ V to }3.6\text{ V}$ ;  $T_{amb} = -40\text{ }^{\circ}\text{C to }+85\text{ }^{\circ}\text{C}$ ; unless otherwise specified.

$SUSPENDM = HIGH$ .

Typical values refer to  $V_{CC} = 3.6\text{ V}$ ;  $V_{CC(I/O)} = 3.3\text{ V}$ ;  $T_{amb} = +25\text{ }^{\circ}\text{C}$ ; unless otherwise specified.

Symbol	Parameter	Conditions	Min	Typ	Max	Unit
$V_{O(REG1V8)}$	output voltage from internal 1.8 V regulator		1.65	1.8	1.95	V
$V_{O(REG3V3)}$	output voltage from internal 3.3 V regulator	not in UART mode	3.0	3.3	3.6	V
		in UART mode	2.5	2.77	2.9	V

**Table 63. Static characteristics: pin XTAL1**

$V_{CC} = 3.0\text{ V to }4.5\text{ V}$ ;  $V_{CC(I/O)} = 3.0\text{ V to }3.6\text{ V}$ ;  $T_{amb} = -40\text{ }^{\circ}\text{C to }+85\text{ }^{\circ}\text{C}$ ; unless otherwise specified.

Symbol	Parameter	Conditions	Min	Typ	Max	Unit
$V_{IL}$	LOW-level input voltage		-	-	0.37	V
$V_{IH}$	HIGH-level input voltage		1.32	-	-	V

## 15. Dynamic characteristics

**Table 64. Dynamic characteristics: reset and power**

$V_{CC} = 3.0\text{ V to }4.5\text{ V}$ ;  $V_{CC(I/O)} = 3.0\text{ V to }3.6\text{ V}$ ;  $T_{amb} = -40\text{ }^{\circ}\text{C to }+85\text{ }^{\circ}\text{C}$ ; unless otherwise specified.

Symbol	Parameter	Conditions	Min	Typ	Max	Unit
$t_{W(POR)}$	internal power-on reset pulse width		0.2	-	-	$\mu\text{s}$
$t_{w(REG1V8\_H)}$	REG1V8 HIGH pulse width		-	-	2	$\mu\text{s}$
$t_{w(REG1V8\_L)}$	REG1V8 LOW pulse width		-	-	11	$\mu\text{s}$
$t_{W(RESET\_N)}$	external RESET_N pulse width		200	-	-	ns
$t_{startup(PLL)}$	PLL start-up time	measured after $t_{d(det)clk(osc)}$	-	-	640	$\mu\text{s}$
$t_{d(det)clk(osc)}$	oscillator clock detector delay	measured from regulator start-up time	-	-	640	$\mu\text{s}$
$t_{PWRUP}$	regulator start-up time	4.7 $\mu\text{F} \pm 20\%$ capacitor each on the REG1V8 and REG3V3 pins	-	-	1	ms
$t_{PWRDN}$	regulator power-down time	4.7 $\mu\text{F} \pm 20\%$ capacitor each on the REG1V8 and REG3V3 pins	-	-	100	ms

**Table 65. Dynamic characteristics: clock applied to XTAL1**

$V_{CC} = 3.0\text{ V to }4.5\text{ V}$ ;  $V_{CC(I/O)} = 3.0\text{ V to }3.6\text{ V}$ ;  $T_{amb} = -40\text{ }^{\circ}\text{C to }+85\text{ }^{\circ}\text{C}$ ; unless otherwise specified.

Typical values refer to  $V_{CC} = 3.6\text{ V}$ ;  $V_{CC(I/O)} = 3.3\text{ V}$ ;  $T_{amb} = +25\text{ }^{\circ}\text{C}$ ; unless otherwise specified.

Symbol	Parameter	Conditions	Min	Typ	Max	Unit
$f_i(XTAL1)$	input frequency on pin XTAL1	see <a href="#">Table 6</a>	-	26.000	-	MHz
		see <a href="#">Table 6</a>	-	24.000	-	MHz
		see <a href="#">Table 6</a>	-	19.300	-	MHz
		see <a href="#">Table 6</a>	-	13.000	-	MHz
$t_{jit(i)(XTAL1)RMS}$	RMS input jitter on pin XTAL1		-	-	200	ps
$\Delta f_i(XTAL1)$	input frequency tolerance on pin XTAL1		-	-	200	ppm
$\delta_i(XTAL1)$	input duty cycle on pin XTAL1	for the first transaction	[1]	50	-	%
$t_r(XTAL1)$	rise time on pin XTAL1	only for square wave input	-	-	5	ns
$t_f(XTAL1)$	fall time on pin XTAL1	only for square wave input	-	-	5	ns

[1] The internal PLL is triggered only on the positive edge from the crystal oscillator. Therefore, the duty cycle is not critical.

**Table 66. Dynamic characteristics: CLOCK output**

$V_{CC} = 3.0\text{ V to }4.5\text{ V}$ ;  $V_{CC(I/O)} = 3.0\text{ V to }3.6\text{ V}$ ;  $T_{amb} = -40\text{ }^{\circ}\text{C to }+85\text{ }^{\circ}\text{C}$ ; unless otherwise specified.

Typical values refer to  $V_{CC} = 3.6\text{ V}$ ;  $V_{CC(I/O)} = 3.3\text{ V}$ ;  $T_{amb} = +25\text{ }^{\circ}\text{C}$ ; unless otherwise specified.

Symbol	Parameter	Conditions	Min	Typ	Max	Unit
$f_{o(AV)(CLOCK)}$	average output frequency on pin CLOCK		59.970	60.000	60.030	MHz
$t_{jit(o)(CLOCK)RMS}$	RMS output jitter on pin CLOCK		-	-	500	ps
$\delta_o(CLOCK)$	output clock duty cycle on pin CLOCK		45	50	55	%

**Table 67. Dynamic characteristics: digital I/O pins (SDR)**

$V_{CC} = 3.0\text{ V to }4.5\text{ V}$ ;  $V_{CC(I/O)} = 3.0\text{ V to }3.6\text{ V}$ ;  $T_{amb} = -40\text{ }^{\circ}\text{C to }+85\text{ }^{\circ}\text{C}$ ; unless otherwise specified. See [Figure 30](#). Typical values refer to  $V_{CC} = 3.6\text{ V}$ ;  $V_{CC(I/O)} = 3.3\text{ V}$ ;  $T_{amb} = +25\text{ }^{\circ}\text{C}$ ; unless otherwise specified.

Symbol	Parameter	Conditions	Min	Typ	Max	Unit
$t_{su(STP)}$	STP set-up time with respect to the rising edge of pin CLOCK	input-only pin (STP)	6.0	-	-	ns
$t_{su(DATA)}$	DATA set-up time with respect to the rising edge of pin CLOCK	bidirectional pins (DATA[7:0]) as inputs	6.0	-	-	ns
$t_h(STP)$	STP hold time with respect to the rising edge of pin CLOCK	input-only pin (STP)	0.0	-	-	ns
$t_h(DATA)$	DATA hold time with respect to the rising edge of pin CLOCK	bidirectional pins (DATA[7:0]) as inputs	0.0	-	-	ns
$t_d(DIR)$	DIR output delay with respect to the rising edge of pin CLOCK	output-only pin DIR	-	-	9.0	ns
$t_d(NXT)$	NXT output delay with respect to the rising edge of pin CLOCK	output-only pin NXT	-	-	9.0	ns
$t_d(DATA)$	DATA output delay with respect to the rising edge of pin CLOCK	bidirectional pins as output (DATA[7:0])	-	-	9.0	ns
$C_L$	load capacitance	pins DATA[7:0], CLOCK, DIR, NXT, STP	[1]	-	-	20 pF

[1] Load capacitance on each ULPI pin.

**Table 68. Dynamic characteristics: digital I/O pins (DDR)**

$V_{CC} = 3.0\text{ V to }4.5\text{ V}$ ;  $V_{CC(I/O)} = 3.0\text{ V to }3.6\text{ V}$ ;  $T_{amb} = -40\text{ }^{\circ}\text{C to }+85\text{ }^{\circ}\text{C}$ ; unless otherwise specified. See [Figure 30](#).

Symbol	Parameter	Conditions	Min	Typ	Max	Unit
$t_{su(STP)}$	STP set-up time with respect to the rising edge of pin CLOCK	input-only pin (STP)	6.0	-	-	ns
$t_{su(DATA)}$	DATA set-up time with respect to the rising edge of pin CLOCK	bidirectional pins (DATA[3:0]) as inputs	[1][2]	4.0	-	ns
$t_h(STP)$	STP hold time with respect to the rising edge of pin CLOCK	input-only pin (STP)	0.0	-	-	ns
$t_h(DATA)$	DATA hold time with respect to the rising edge of pin CLOCK	bidirectional pins (DATA[7:0]) as inputs	[2]	0.0	-	ns
$t_d(DIR)$	DIR output delay with respect to the rising edge of pin CLOCK	output-only pin DIR	-	-	9.0	ns
$t_d(NXT)$	NXT output delay with respect to the rising edge of pin CLOCK	output-only pin NXT	-	-	9.0	ns
$t_d(DATA)$	DATA output delay with respect to the rising edge of pin CLOCK	bidirectional pins (DATA[3:0]) as output	[2]	-	4.4	ns
$C_L$	load capacitance	pins DATA[3:0], CLOCK, DIR, NXT, STP	[3]			
		$t_d = 4\text{ ns}$	-	-	10	pF
		$t_d = 4.4\text{ ns}$	-	-	15	pF

[1] Note that the value exceeds that specified in *UTMI+ Low Pin Interface (ULPI) Specification Rev. 1.1*.

[2] Also with respect to the falling edge of pin CLOCK.

[3] Load capacitance on each ULPI pin.

**Table 69. Dynamic characteristics: analog I/O pins (DP, DM) in USB mode**

$V_{CC} = 3.0\text{ V to }4.5\text{ V}$ ;  $V_{CC(I/O)} = 3.0\text{ V to }3.6\text{ V}$ ;  $T_{amb} = -40\text{ }^{\circ}\text{C to }+85\text{ }^{\circ}\text{C}$ ; unless otherwise specified.  
 Typical values refer to  $V_{CC} = 3.6\text{ V}$ ;  $V_{CC(I/O)} = 3.3\text{ V}$ ;  $T_{amb} = +25\text{ }^{\circ}\text{C}$ ; unless otherwise specified.

Symbol	Parameter	Conditions	Min	Typ	Max	Unit
<b>High-speed driver characteristics; see Figure 26</b>						
$t_{HSR}$	rise time (10 % to 90 %)	drive 45 $\Omega$ to GND on DP and DM	500	-	-	ps
$t_{HSF}$	fall time (10 % to 90 %)	drive 45 $\Omega$ to GND on DP and DM	500	-	-	ps
<b>Full-speed driver characteristics; see Figure 26</b>						
$t_{FR}$	rise time	$C_L = 50\text{ pF}$ ; 10 % to 90 % of $ V_{OH} - V_{OL} $	4	-	20	ns
$t_{FF}$	fall time	$C_L = 50\text{ pF}$ ; 10 % to 90 % of $ V_{OH} - V_{OL} $	4	-	20	ns
$t_{FRFM}$	differential rise and fall time matching	$t_{FR} / t_{FF}$ ; excluding the first transition from the idle state	90	-	111.1	%
<b>Low-speed driver characteristics; see Figure 26</b>						
$t_{LR}$	transition time: rise time	$C_L = 200\text{ pF to }600\text{ pF}$ ; 1.5 k $\Omega$ pull-up on DM enabled; 10 % to 90 % of $ V_{OH} - V_{OL} $	75	-	300	ns
$t_{LF}$	transition time: fall time	$C_L = 200\text{ pF to }600\text{ pF}$ ; 1.5 k $\Omega$ pull-up on DM enabled; 10 % to 90 % of $ V_{OH} - V_{OL} $	75	-	300	ns
$t_{LRFM}$	rise and fall time matching	$t_{LR} / t_{LF}$ ; excluding the first transition from the idle state	80	-	125	%

**Table 70. Dynamic characteristics: analog I/O pins (DP, DM) in transparent UART mode**

$V_{CC} = 3.0\text{ V to }4.5\text{ V}$ ;  $V_{CC(I/O)} = 3.0\text{ V to }3.6\text{ V}$ ;  $T_{amb} = -40\text{ }^{\circ}\text{C to }+85\text{ }^{\circ}\text{C}$ ; unless otherwise specified.

Symbol	Parameter	Conditions	Min	Typ	Max	Unit
<b>Full-speed driver characteristics (DM only)</b>						
$t_{r(UART)}$	rise time for UART TXD	$C_L = 185\text{ pF}$ ; 0.37 V to 2.16 V	25	-	75	ns
$t_{f(UART)}$	fall time for UART TXD	$C_L = 185\text{ pF}$ ; 2.16 V to 0.37 V	25	-	75	ns
$t_{PLH(drv)}$	driver propagation delay (LOW to HIGH)	$C_L = 185\text{ pF}$ ; DATA0 to DM	-	-	39	ns
$t_{PHL(drv)}$	driver propagation delay (HIGH to LOW)	$C_L = 185\text{ pF}$ ; DATA0 to DM	-	-	34	ns
<b>Low-speed driver characteristics (DM only)</b>						
$t_{r(UART)}$	rise time for UART TXD	$C_L = 185\text{ pF}$ ; 0.37 V to 2.16 V	100	-	400	ns
$t_{f(UART)}$	fall time for UART TXD	$C_L = 185\text{ pF}$ ; 2.16 V to 0.37 V	100	-	400	ns
$t_{PLH(drv)}$	driver propagation delay (LOW to HIGH)	$C_L = 185\text{ pF}$ ; DATA0 to DM	-	-	614	ns
$t_{PHL(drv)}$	driver propagation delay (HIGH to LOW)	$C_L = 185\text{ pF}$ ; DATA0 to DM	-	-	614	ns
<b>Full-speed receiver characteristics (DP only)</b>						
$t_{PLH(rcv)}$	receiver propagation delay (LOW to HIGH)	DP to DATA1	-	-	7	ns
$t_{PHL(rcv)}$	receiver propagation delay (HIGH to LOW)	DP to DATA1	-	-	7	ns
<b>Low-speed receiver characteristics (DP only)</b>						
$t_{PLH(rcv)}$	receiver propagation delay (LOW to HIGH)	DP to DATA1	-	-	7	ns
$t_{PHL(rcv)}$	receiver propagation delay (HIGH to LOW)	DP to DATA1	-	-	7	ns



**Table 71. Dynamic characteristics: analog I/O pins (DP, DM) in serial mode**

$V_{CC} = 3.0\text{ V to }4.5\text{ V}$ ;  $V_{CC(I/O)} = 3.0\text{ V to }3.6\text{ V}$ ;  $T_{amb} = -40\text{ }^{\circ}\text{C to }+85\text{ }^{\circ}\text{C}$ ; unless otherwise specified.

Symbol	Parameter	Conditions	Min	Typ	Max	Unit
<b>Driver timing (valid only for serial mode)</b>						
$t_{PLH(drv)}$	driver propagation delay (LOW to HIGH)	TX_DAT, TX_SE0 to DP, DM; see <a href="#">Figure 27</a>	-	-	11	ns
$t_{PHL(drv)}$	driver propagation delay (HIGH to LOW)	TX_DAT, TX_SE0 to DP, DM; see <a href="#">Figure 27</a>	-	-	11	ns
$t_{PHZ}$	driver disable delay from HIGH level	TX_ENABLE to DP, DM; see <a href="#">Figure 28</a>	-	-	12	ns
$t_{PLZ}$	driver disable delay from LOW level	TX_ENABLE to DP, DM; see <a href="#">Figure 28</a>	-	-	12	ns
$t_{PZH}$	driver enable delay to HIGH level	TX_ENABLE to DP, DM; see <a href="#">Figure 28</a>	-	-	20	ns
$t_{PZL}$	driver enable delay to LOW level	TX_ENABLE to DP, DM; see <a href="#">Figure 28</a>	-	-	20	ns
<b>Receiver timing (valid only for serial mode)</b>						
<b>Differential receiver</b>						
$t_{PLH(rcv)}$	receiver propagation delay (LOW to HIGH)	DP, DM to RX_RCV, RX_DP and RX_DM; see <a href="#">Figure 29</a>	-	-	17	ns
$t_{PHL(rcv)}$	receiver propagation delay (HIGH to LOW)	DP, DM to RX_RCV, RX_DP and RX_DM; see <a href="#">Figure 29</a>	-	-	17	ns
<b>Single-ended receiver</b>						
$t_{PLH(se)}$	single-ended propagation delay (LOW to HIGH)	DP, DM to RX_RCV, RX_DP and RX_DM; see <a href="#">Figure 29</a>	-	-	17	ns
$t_{PHL(se)}$	single-ended propagation delay (HIGH to LOW)	DP, DM to RX_RCV, RX_DP and RX_DM; see <a href="#">Figure 29</a>	-	-	17	ns

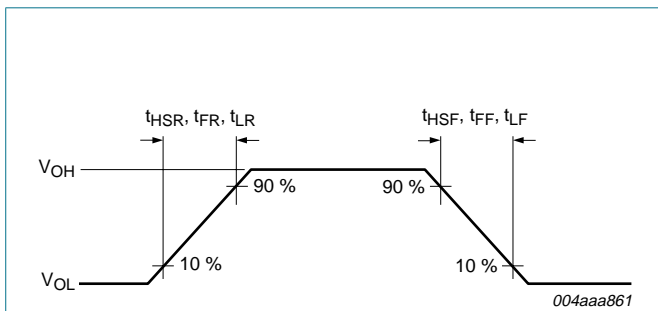

**Fig 26. Rise time and fall time**

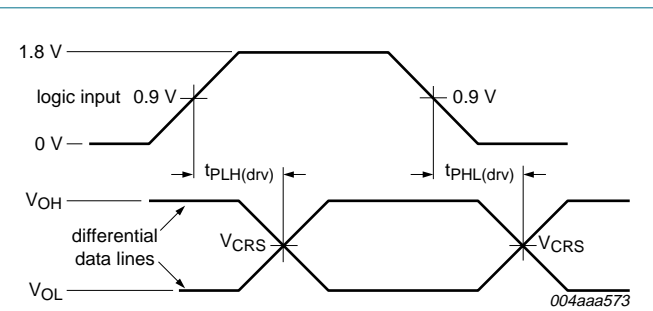

**Fig 27. Timing of TX\_DAT and TX\_SE0 to DP and DM**

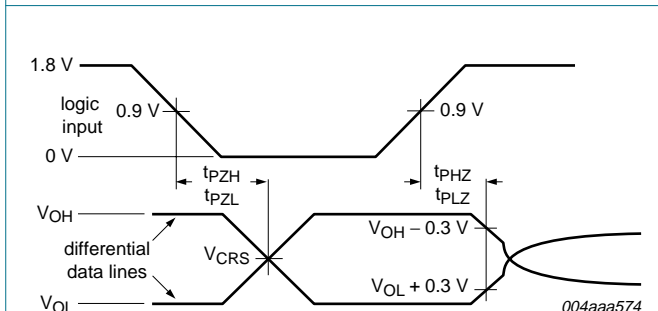

**Fig 28. Timing of TX\_ENABLE to DP and DM**

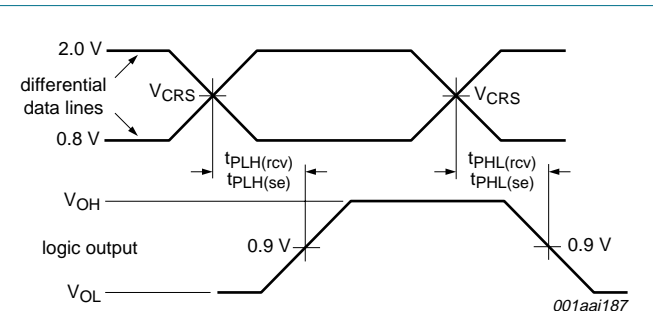

**Fig 29. Timing of DP and DM to RX\_RCV, RX\_DP and RX\_DM**

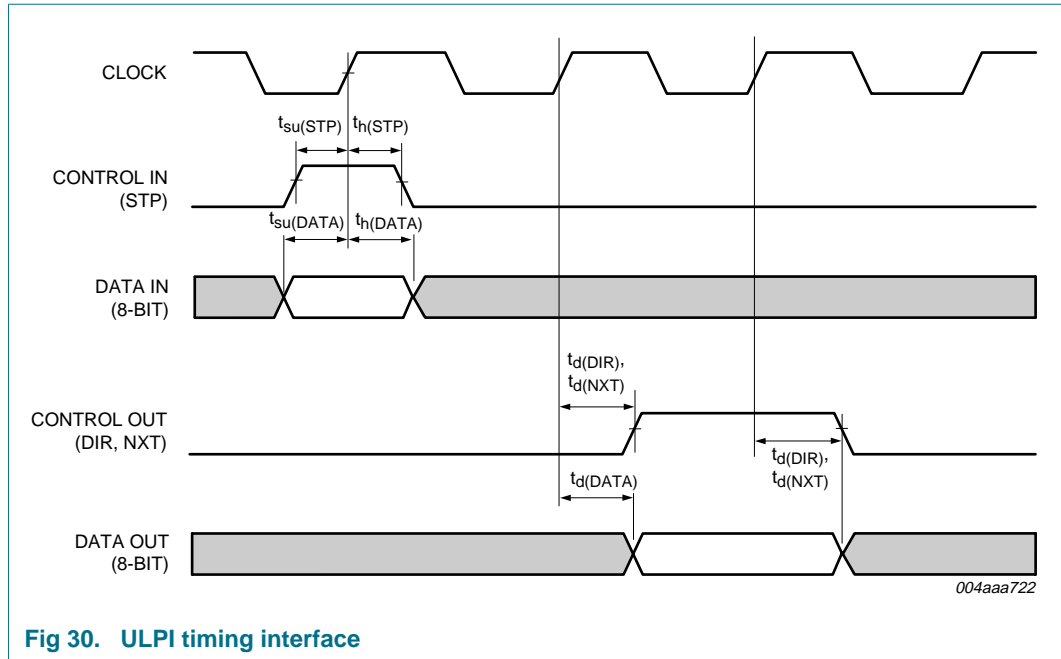
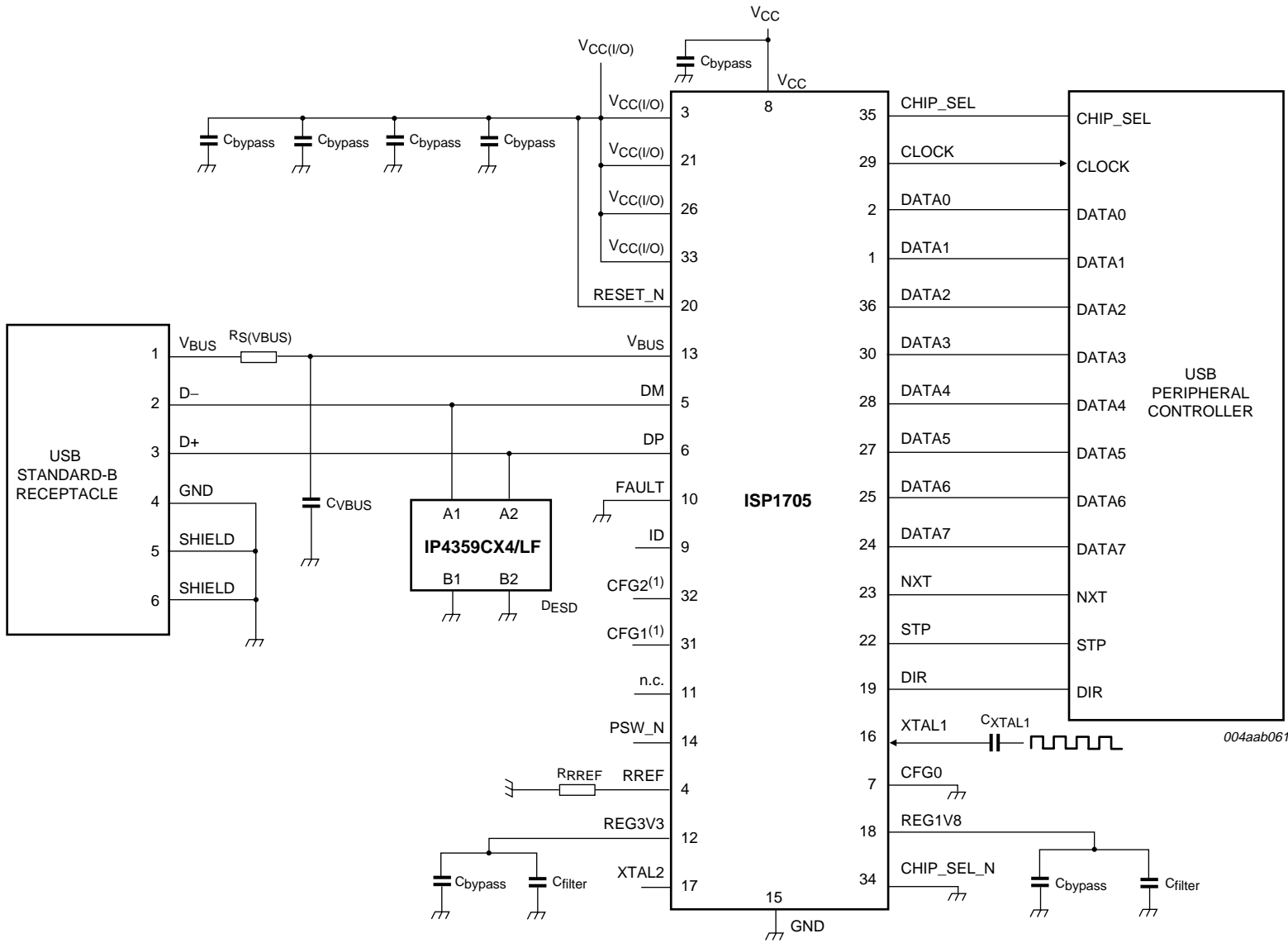

Fig 30. ULPI timing interface

## 16. Application information

Table 72. Recommended bill of materials

Designator	Application	Part type	Remark
$C_{bypass}$	highly recommended for all applications	0.1 $\mu F \pm 20\%$	-
$C_{filter}$	highly recommended for all applications	4.7 $\mu F \pm 20\%$	use a LOW ESR capacitor (0.2 $\Omega$ to 2 $\Omega$ ) for best performance
$C_{VBUS}$	mandatory for peripherals	1 $\mu F$ to 10 $\mu F$	use low ESR capacitor
	mandatory for host	120 $\mu F$ (min)	use low ESR capacitor
	mandatory for OTG	1 $\mu F$ to 6.5 $\mu F$	use low ESR capacitor
$C_{XTAL}$	in all applications	18 pF $\pm 20\%$	-
$D_{ESD}$	recommended to prevent damages from ESD	-	IP4359CX4/LF; Wafer-Level Chip-Scale Package (WLCSP); ESD IEC 61000-4-2 level 4; $\pm 15$ kV contact; $\pm 15$ kV air discharge compliant protection. Note: ISP1705 and IP4359CX4/LF together have an IEC 61000-4-2 contact discharge tolerance of $\pm 20$ kV.
$R_{RREF}$	mandatory in all applications	12 k $\Omega \pm 1\%$	-
$R_{S(VBUS)}$	recommended for peripherals or external 5 V applications	1 k $\Omega \pm 5\%$	-
$R_{pullup}$	recommended; for applications with an external $V_{BUS}$ supply controlled by PSW_N	10 k $\Omega$	-
xtal	mandatory in all applications	19.2 MHz	$C_L = 10$ pF; $R_S < 220 \Omega$ ; $C_{XTAL} = 18$ pF
		24 MHz	$C_L = 10$ pF; $R_S < 160 \Omega$ ; $C_{XTAL} = 18$ pF



This figure shows the HVQFN pinout. For the TFBGA ballout, see [Table 3](#).

(1) Connect to either GND or V<sub>CC(I/O)</sub>, depending on the clock frequency used. See [Table 6](#).

**Fig 31. ISP1705 in peripheral-only application**

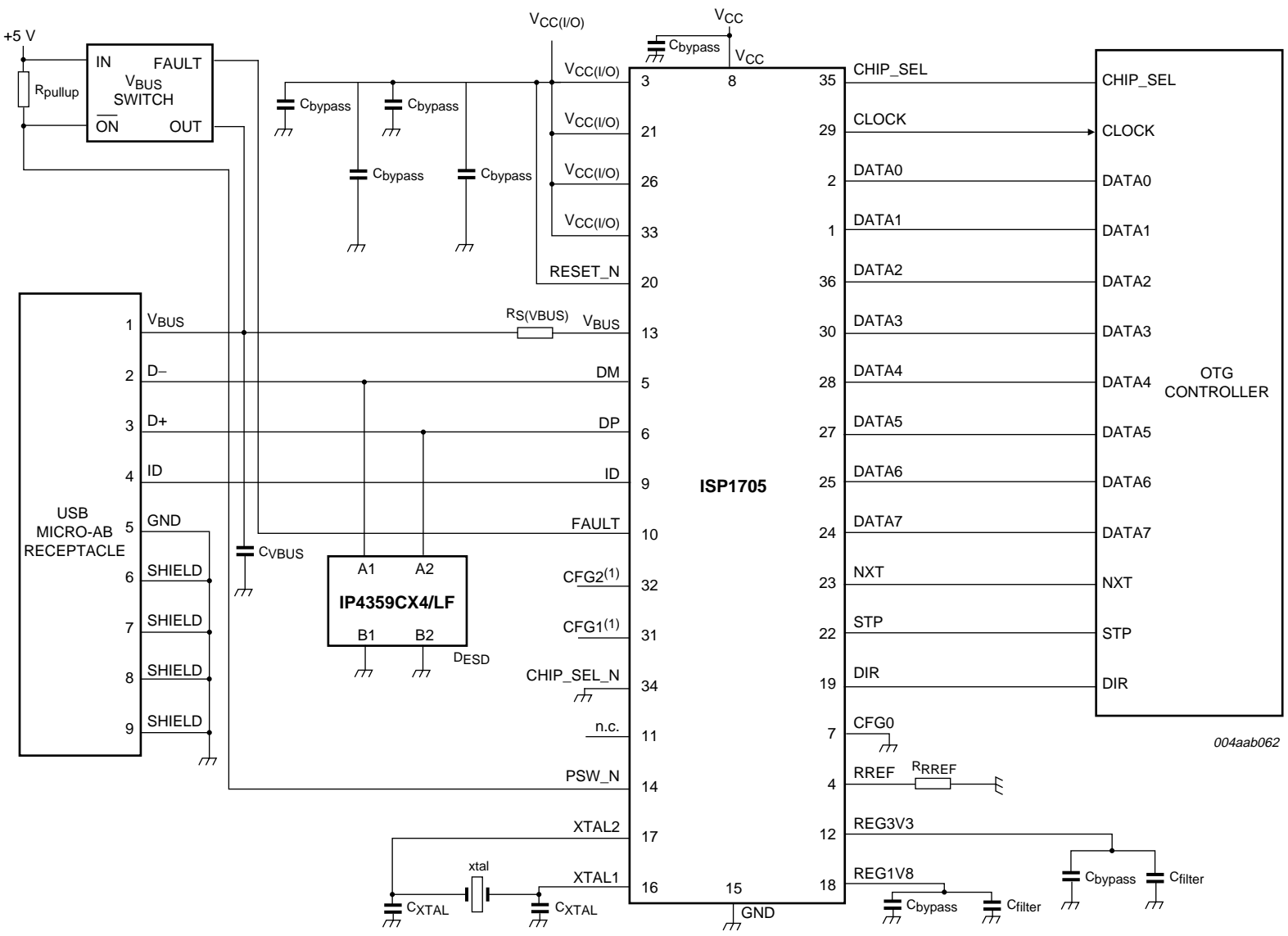

This figure shows the HVQFN pinout. For the TFBGA ballout, see [Table 3](#).  
 (1) Connect to either GND or  $V_{CC(I/O)}$ , depending on the crystal frequency used. See [Table 6](#).

**Fig 32. ISP1705 in OTG application**

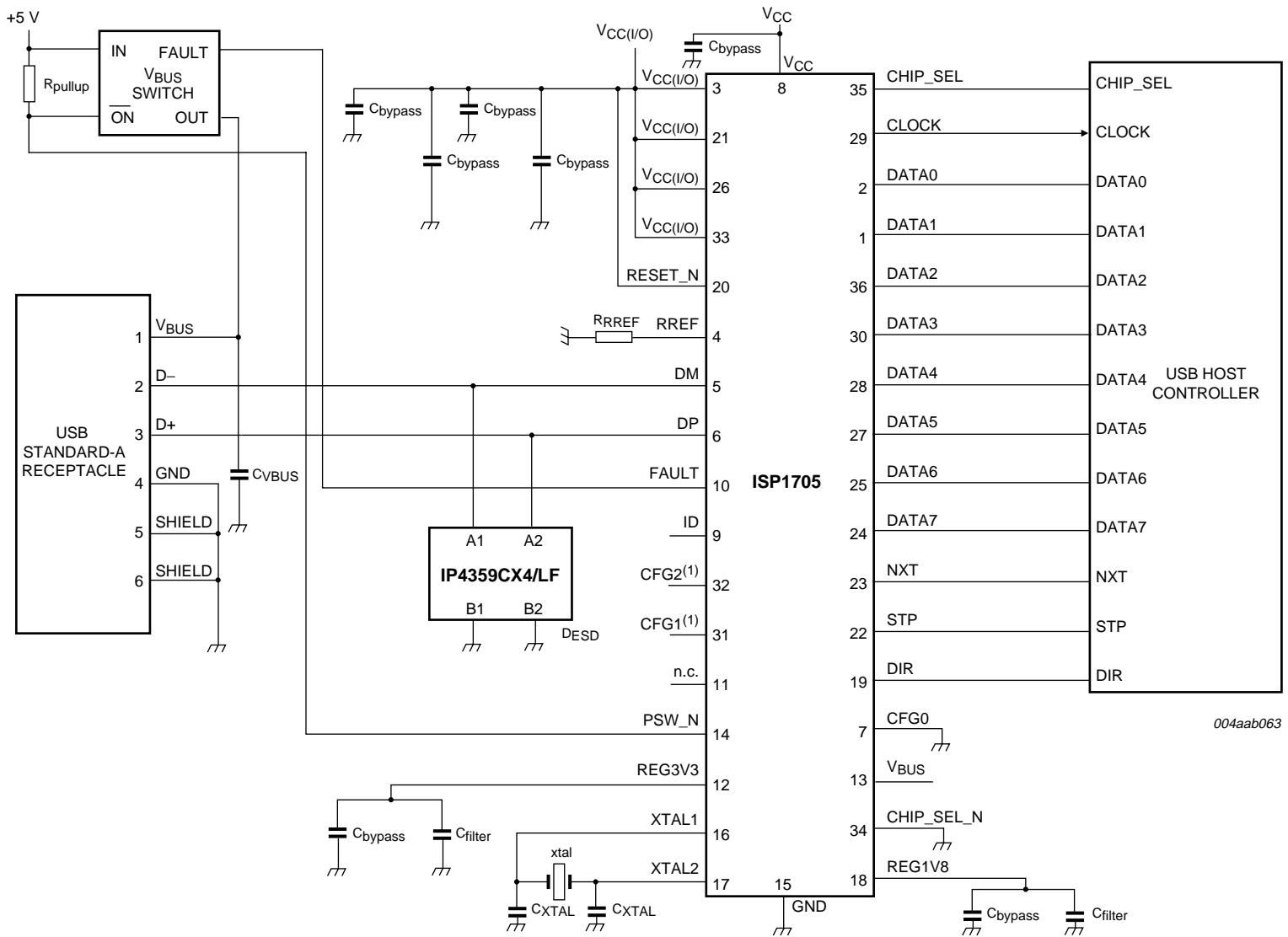

This figure shows the HVQFN pinout. For the TFBGA ballout, see [Table 3](#).  
 (1) Connect to either GND or V<sub>CC(I/O)</sub>, depending on the crystal frequency used. See [Table 6](#).

**Fig 33. ISP1705 in host application**

17. Package outline

HVQFN36: plastic thermal enhanced very thin quad flat package; no leads;  
36 terminals; body 5 x 5 x 0.85 mm

SOT818-1

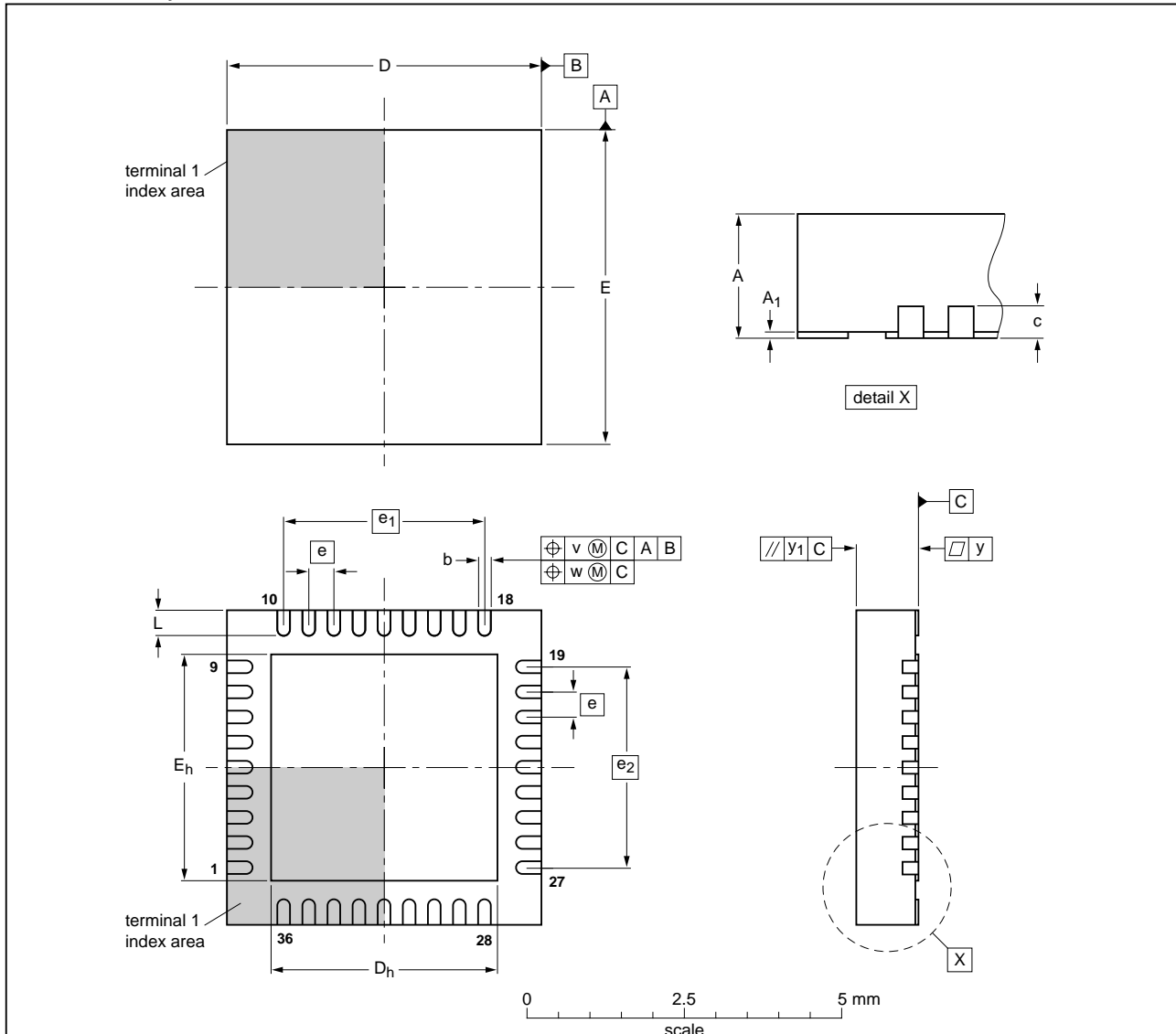

DIMENSIONS (mm are the original dimensions)

UNIT	A <sup>(1)</sup> max	A <sub>1</sub>	b	c	D <sup>(1)</sup>	D <sub>h</sub>	E <sup>(1)</sup>	E <sub>h</sub>	e	e <sub>1</sub>	e <sub>2</sub>	L	v	w	y	y <sub>1</sub>
mm	1	0.05 0.00	0.30 0.18	0.2	5.1 4.9	3.75 3.45	5.1 4.9	3.75 3.45	0.4	3.2	3.2	0.5 0.3	0.1	0.05	0.05	0.1

Note  
1. Plastic or metal protrusions of 0.075 mm maximum per side are not included.

OUTLINE VERSION	REFERENCES				EUROPEAN PROJECTION	ISSUE DATE
	IEC	JEDEC	JEITA			
SOT818-1	---	MO-220	---			03-06-13

Fig 34. Package outline SOT818-1 (HVQFN36)

TFBGA36: plastic thin fine-pitch ball grid array package; 36 balls; body 3.5 x 3.5 x 0.8 mm

SOT912-1

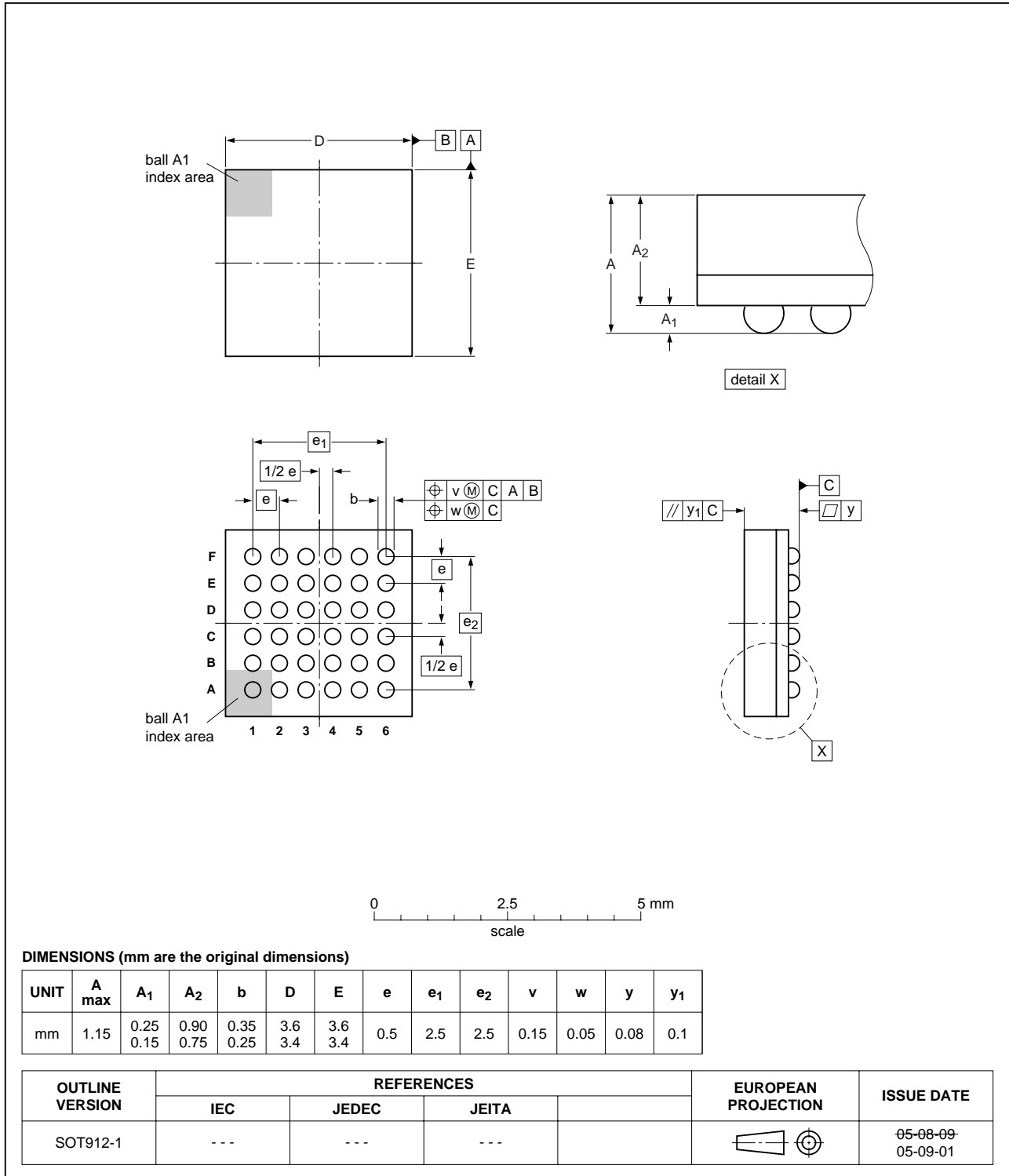

Fig 35. Package outline SOT912-1 (TFBGA36)

## 18. Soldering of SMD packages

This text provides a very brief insight into a complex technology. A more in-depth account of soldering ICs can be found in Application Note *AN10365 "Surface mount reflow soldering description"*.

### 18.1 Introduction to soldering

Soldering is one of the most common methods through which packages are attached to Printed Circuit Boards (PCBs), to form electrical circuits. The soldered joint provides both the mechanical and the electrical connection. There is no single soldering method that is ideal for all IC packages. Wave soldering is often preferred when through-hole and Surface Mount Devices (SMDs) are mixed on one printed wiring board; however, it is not suitable for fine pitch SMDs. Reflow soldering is ideal for the small pitches and high densities that come with increased miniaturization.

### 18.2 Wave and reflow soldering

Wave soldering is a joining technology in which the joints are made by solder coming from a standing wave of liquid solder. The wave soldering process is suitable for the following:

- Through-hole components
- Leaded or leadless SMDs, which are glued to the surface of the printed circuit board

Not all SMDs can be wave soldered. Packages with solder balls, and some leadless packages which have solder lands underneath the body, cannot be wave soldered. Also, leaded SMDs with leads having a pitch smaller than ~0.6 mm cannot be wave soldered, due to an increased probability of bridging.

The reflow soldering process involves applying solder paste to a board, followed by component placement and exposure to a temperature profile. Leaded packages, packages with solder balls, and leadless packages are all reflow solderable.

Key characteristics in both wave and reflow soldering are:

- Board specifications, including the board finish, solder masks and vias
- Package footprints, including solder thieves and orientation
- The moisture sensitivity level of the packages
- Package placement
- Inspection and repair
- Lead-free soldering versus SnPb soldering

### 18.3 Wave soldering

Key characteristics in wave soldering are:

- Process issues, such as application of adhesive and flux, clinching of leads, board transport, the solder wave parameters, and the time during which components are exposed to the wave
- Solder bath specifications, including temperature and impurities



### 18.4 Reflow soldering

Key characteristics in reflow soldering are:

- Lead-free versus SnPb soldering; note that a lead-free reflow process usually leads to higher minimum peak temperatures (see [Figure 36](#)) than a SnPb process, thus reducing the process window
- Solder paste printing issues including smearing, release, and adjusting the process window for a mix of large and small components on one board
- Reflow temperature profile; this profile includes preheat, reflow (in which the board is heated to the peak temperature) and cooling down. It is imperative that the peak temperature is high enough for the solder to make reliable solder joints (a solder paste characteristic). In addition, the peak temperature must be low enough that the packages and/or boards are not damaged. The peak temperature of the package depends on package thickness and volume and is classified in accordance with [Table 73](#) and [74](#)

**Table 73. SnPb eutectic process (from J-STD-020C)**

Package thickness (mm)	Package reflow temperature (°C)	
	Volume (mm <sup>3</sup> )	
	< 350	≥ 350
< 2.5	235	220
≥ 2.5	220	220

**Table 74. Lead-free process (from J-STD-020C)**

Package thickness (mm)	Package reflow temperature (°C)		
	Volume (mm <sup>3</sup> )		
	< 350	350 to 2000	> 2000
< 1.6	260	260	260
1.6 to 2.5	260	250	245
> 2.5	250	245	245

Moisture sensitivity precautions, as indicated on the packing, must be respected at all times.

Studies have shown that small packages reach higher temperatures during reflow soldering, see [Figure 36](#).

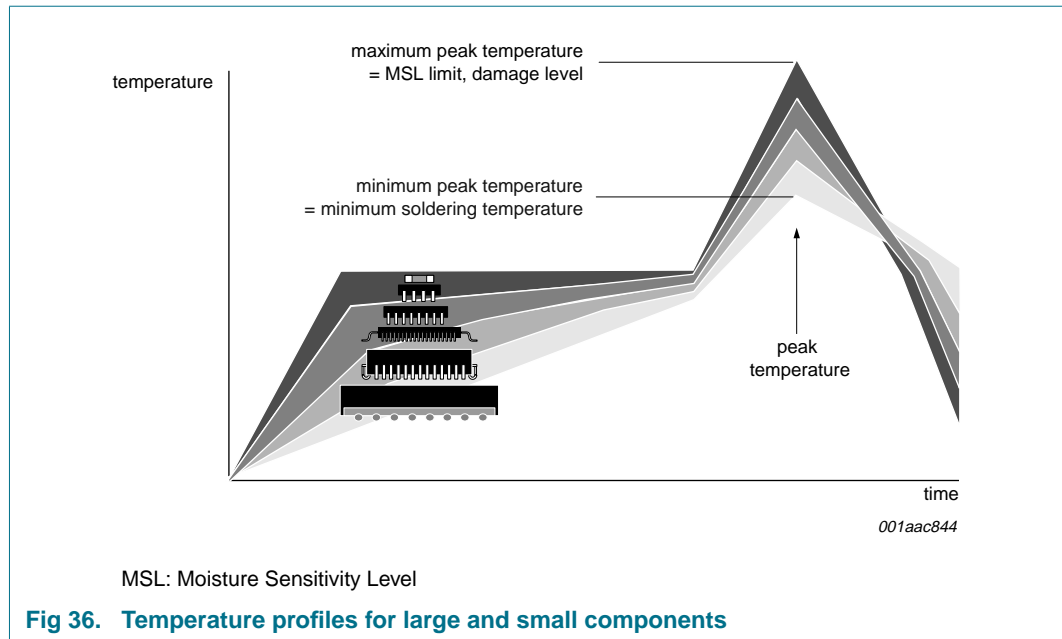

For further information on temperature profiles, refer to Application Note AN10365 “Surface mount reflow soldering description”.

## 19. Abbreviations

**Table 75. Abbreviations**

Acronym	Description
ASIC	Application Specific Integrated Circuit
ATX	Analog USB Transceiver
CDM	Charged Device Model
CD-DVD	Compact Disc - Digital Video Disc
CD-ROM	Compact Disc - Read-Only Memory
CD-RW	Compact Disc - ReWritable
DDR	Dual Data Rate
EMI	ElectroMagnetic Interference
EOP	End-Of-Packet
ESD	ElectroStatic Discharge
ESR	Effective Series Resistance
FPGA	Field Programmable Gate-Array
FS	Full Speed
HBM	Human Body Model
HNP	Host Negotiation Protocol
HS	High Speed
ID	Identification
IEC	International Electrotechnical Commission
LS	Low Speed

Table 75. Abbreviations ...continued

Acronym	Description
MM	Machine Model
NRZI	Non-Return to Zero Inverted
OTG	On-The-Go
PDA	Personal Digital Assistant
PHY	Physical
PID	Packet Identifier
PLL	Phase-Locked Loop
POR	Power-On Reset
RoHS	Restriction of Hazardous Substances
RXCMD	Receive Command
RXD	Receive Data
SDR	Single Data Rate
SE0	Single-Ended Zero
SOC	System-On-Chip
SOF	Start-Of-Frame
SRP	Session Request Protocol
SYNC	Synchronous
TTL	Transistor-Transistor Logic
TXCMD	Transmit Command
TXD	Transmit Data
UART	Universal Asynchronous Receiver-Transmitter
ULPI	UTMI+ Low Pin Interface
USB	Universal Serial Bus
USB-IF	USB Implementers Forum
UTMI	USB Transceiver Macrocell Interface
UTMI+	USB Transceiver Macrocell Interface Plus
WLCSP	Wafer-Level Chip-Scale Package

## 20. Glossary

**A-device** — An OTG device with an attached micro-A plug.

**B-device** — An OTG device with an attached micro-B plug.

**Link** — ASIC, SOC or FPGA that contains the USB host or peripheral core.

**PHY** — Physical layer containing the USB transceiver.

## 21. References

- [1] Universal Serial Bus Specification Rev. 2.0
- [2] On-The-Go Supplement to the USB 2.0 Specification Rev. 1.3
- [3] UTMI+ Low Pin Interface (ULPI) Specification Rev. 1.1

- [4] UTMI+ Specification Rev. 1.0
- [5] USB 2.0 Transceiver Macrocell Interface (UTMI) Specification Ver. 1.05
- [6] Electrostatic Discharge (ESD) Sensitivity Testing Human Body Model (HBM) (JESD22-A114D)
- [7] Electrostatic Discharge (ESD) Sensitivity Testing Machine Model (MM) (JESD22-A115-A)
- [8] Field-Induced Charged-Device Model Test Method for Electrostatic-Discharge-Withstand Thresholds of Microelectronic Components (JESD22-C101-C)
- [9] Electromagnetic compatibility (EMC) - Part 4-2: Testing and measurement techniques - Electrostatic discharge immunity test (IEC 61000-4-2)

## 22. Revision history

Table 76. Revision history

Document ID	Release date	Data sheet status	Change notice	Supersedes
ISP1705_1	20080613	Product data sheet	-	-

## 23. Legal information

### 23.1 Data sheet status

Document status <sup>[1][2]</sup>	Product status <sup>[3]</sup>	Definition
Objective [short] data sheet	Development	This document contains data from the objective specification for product development.
Preliminary [short] data sheet	Qualification	This document contains data from the preliminary specification.
Product [short] data sheet	Production	This document contains the product specification.

[1] Please consult the most recently issued document before initiating or completing a design.

[2] The term 'short data sheet' is explained in section "Definitions".

[3] The product status of device(s) described in this document may have changed since this document was published and may differ in case of multiple devices. The latest product status information is available on the Internet at URL <http://www.nxp.com>.

### 23.2 Definitions

**Draft** — The document is a draft version only. The content is still under internal review and subject to formal approval, which may result in modifications or additions. NXP Semiconductors does not give any representations or warranties as to the accuracy or completeness of information included herein and shall have no liability for the consequences of use of such information.

**Short data sheet** — A short data sheet is an extract from a full data sheet with the same product type number(s) and title. A short data sheet is intended for quick reference only and should not be relied upon to contain detailed and full information. For detailed and full information see the relevant full data sheet, which is available on request via the local NXP Semiconductors sales office. In case of any inconsistency or conflict with the short data sheet, the full data sheet shall prevail.

### 23.3 Disclaimers

**General** — Information in this document is believed to be accurate and reliable. However, NXP Semiconductors does not give any representations or warranties, expressed or implied, as to the accuracy or completeness of such information and shall have no liability for the consequences of use of such information.

**Right to make changes** — NXP Semiconductors reserves the right to make changes to information published in this document, including without limitation specifications and product descriptions, at any time and without notice. This document supersedes and replaces all information supplied prior to the publication hereof.

**Suitability for use** — NXP Semiconductors products are not designed, authorized or warranted to be suitable for use in medical, military, aircraft, space or life support equipment, nor in applications where failure or

malfunction of an NXP Semiconductors product can reasonably be expected to result in personal injury, death or severe property or environmental damage. NXP Semiconductors accepts no liability for inclusion and/or use of NXP Semiconductors products in such equipment or applications and therefore such inclusion and/or use is at the customer's own risk.

**Applications** — Applications that are described herein for any of these products are for illustrative purposes only. NXP Semiconductors makes no representation or warranty that such applications will be suitable for the specified use without further testing or modification.

**Limiting values** — Stress above one or more limiting values (as defined in the Absolute Maximum Ratings System of IEC 60134) may cause permanent damage to the device. Limiting values are stress ratings only and operation of the device at these or any other conditions above those given in the Characteristics sections of this document is not implied. Exposure to limiting values for extended periods may affect device reliability.

**Terms and conditions of sale** — NXP Semiconductors products are sold subject to the general terms and conditions of commercial sale, as published at <http://www.nxp.com/profile/terms>, including those pertaining to warranty, intellectual property rights infringement and limitation of liability, unless explicitly otherwise agreed to in writing by NXP Semiconductors. In case of any inconsistency or conflict between information in this document and such terms and conditions, the latter will prevail.

**No offer to sell or license** — Nothing in this document may be interpreted or construed as an offer to sell products that is open for acceptance or the grant, conveyance or implication of any license under any copyrights, patents or other industrial or intellectual property rights.

### 23.4 Trademarks

Notice: All referenced brands, product names, service names and trademarks are the property of their respective owners.

## 24. Contact information

For more information, please visit: <http://www.nxp.com>

For sales office addresses, please send an email to: [salesaddresses@nxp.com](mailto:salesaddresses@nxp.com)

25. Tables

Table 1.	Ordering information	3			
Table 2.	Marking codes	3			
Table 3.	Pin description	6			
Table 4.	Recommended $V_{BUS}$ capacitor value	18			
Table 5.	OTG_CTRL register power control bits	19			
Table 6.	Allowed crystal or clock frequency on the XTAL1 pin	19			
Table 7.	External capacitor values for 13 MHz or 19.2 MHz clock frequency	20			
Table 8.	External capacitor values for 24 MHz or 26 MHz clock frequency	20			
Table 9.	Pin states in Power-down mode	22			
Table 10.	ULPI signal description	23			
Table 11.	Signal mapping during low-power mode	24			
Table 12.	Signal mapping for 6-pin serial mode	25			
Table 13.	Signal mapping for 3-pin serial mode	26			
Table 14.	UART signal mapping	26			
Table 15.	Operating states and their corresponding resistor settings	29			
Table 16.	TXCMD byte format	31			
Table 17.	RXCMD byte format	32			
Table 18.	LINESTATE[1:0] encoding for upstream facing ports: peripheral	33			
Table 19.	LINESTATE[1:0] encoding for downstream facing ports: host	33			
Table 20.	Encoded $V_{BUS}$ voltage state	33			
Table 21.	$V_{BUS}$ indicators in RXCMD required for typical applications	34			
Table 22.	Encoded USB event signals	35			
Table 23.	PHY pipeline delays	39			
Table 24.	Link decision times	40			
Table 25.	Register map	52			
Table 26.	VENDOR_ID_LOW - Vendor ID low register (address R = 00h) bit description	52			
Table 27.	VENDOR_ID_HIGH - Vendor ID high register (address R = 01h) bit description	52			
Table 28.	PRODUCT_ID_LOW - Product ID low register (address R = 02h) bit description	53			
Table 29.	PRODUCT_ID_HIGH - Product ID high register (address R = 03h) bit description	53			
Table 30.	FUNC_CTRL - Function control register (address R = 04h to 06h, W = 04h, S = 05h, C = 06h) bit allocation	53			
Table 31.	FUNC_CTRL - Function control register (address R = 04h to 06h, W = 04h, S = 05h, C = 06h) bit description	53			
Table 32.	INTF_CTRL - Interface control register (address R = 07h to 09h, W = 07h, S = 08h, C = 09h) bit allocation	55			
Table 33.	INTF_CTRL - Interface control register (address R = 07h to 09h, W = 07h, S = 08h, C = 09h) bit description	55			
Table 34.	OTG_CTRL - OTG control register (address R = 0Ah to 0Ch, W = 0Ah, S = 0Bh, C = 0Ch) bit allocation	56			
Table 35.	OTG_CTRL - OTG control register (address R = 0Ah to 0Ch, W = 0Ah, S = 0Bh, C = 0Ch) bit description	57			
Table 36.	USB_INTR_EN_R - USB interrupt enable rising register (address R = 0Dh to 0Fh, W = 0Dh, S = 0Eh, C = 0Fh) bit allocation	58			
Table 37.	USB_INTR_EN_R - USB interrupt enable rising register (address R = 0Dh to 0Fh, W = 0Dh, S = 0Eh, C = 0Fh) bit description	58			
Table 38.	USB_INTR_EN_F - USB interrupt enable falling register (address R = 10h to 12h, W = 10h, S = 11h, C = 12h) bit allocation	58			
Table 39.	USB_INTR_EN_F - USB interrupt enable falling register (address R = 10h to 12h, W = 10h, S = 11h, C = 12h) bit description	59			
Table 40.	USB_INTR_STAT - USB interrupt status register (address R = 13h) bit allocation	59			
Table 41.	USB_INTR_STAT - USB interrupt status register (address R = 13h) bit description	59			
Table 42.	USB_INTR_L - USB interrupt latch register (address R = 14h) bit allocation	60			
Table 43.	USB_INTR_L - USB interrupt latch register (address R = 14h) bit description	60			
Table 44.	DEBUG - Debug register (address R = 15h) bit allocation	60			
Table 45.	DEBUG - Debug register (address R = 15h) bit description	60			
Table 46.	SCRATCH - Scratch register (address R = 16h to 18h, W = 16h, S = 17h, C = 18h) bit description	61			
Table 47.	CARKIT_CTRL - Carkit control register (address R = 19h to 1Bh, W = 19h, S = 1Ah, C = 1Bh) bit allocation	61			
Table 48.	CARKIT_CTRL - Carkit control register (address R = 19h to 1Bh, W = 19h, S = 1Ah, C = 1Bh) bit description	61			
Table 49.	PWR_CTRL - Power control register (address R = 3Dh to 3Fh, W = 3Dh, S = 3Eh, C = 3Fh) bit allocation	62			
Table 50.	PWR_CTRL - Power control register (address R = 3Dh to 3Fh, W = 3Dh, S = 3Eh, C = 3Fh) bit description	62			

continued >>

C = 3Fh) bit description .....62

Table 51. Limiting values .....63

Table 52. Recommended operating conditions .....63

Table 53. Static characteristics: supply pins .....64

Table 54. Static characteristics: digital pins .....64

Table 55. Static characteristics: digital input pin  
FAULT .....65

Table 56. Static characteristics: digital output pin  
PSW\_N .....65

Table 57. Static characteristics: analog pins (DP, DM) . .65

Table 58. Static characteristics: analog pin  $V_{BUS}$  .....67

Table 59. Static characteristics: analog pin CFG0 .....68

Table 60. Static characteristics: ID detection circuit . . .68

Table 61. Static characteristics: resistor reference . . .68

Table 62. Static characteristics: regulator .....68

Table 63. Static characteristics: pin XTAL1 .....68

Table 64. Dynamic characteristics: reset and power . . .69

Table 65. Dynamic characteristics: clock applied to  
XTAL1 .....69

Table 66. Dynamic characteristics: CLOCK output . . . .69

Table 67. Dynamic characteristics: digital I/O pins  
(SDR) .....70

Table 68. Dynamic characteristics: digital I/O pins  
(DDR) .....70

Table 69. Dynamic characteristics: analog I/O pins  
(DP, DM) in USB mode .....71

Table 70. Dynamic characteristics: analog I/O pins  
(DP, DM) in transparent UART mode .....71

Table 71. Dynamic characteristics: analog I/O pins  
(DP, DM) in serial mode .....72

Table 72. Recommended bill of materials .....73

Table 73. SnPb eutectic process (from J-STD-020C) . . .80

Table 74. Lead-free process (from J-STD-020C) .....80

Table 75. Abbreviations .....81

Table 76. Revision history .....83

26. Figures

Fig 1. Block diagram .....4

Fig 2. Pin configuration HVQFN36.....5

Fig 3. Pin configuration TFBGA36.....5

Fig 4. Digital overcurrent detection scheme.....12

Fig 5. Internal power-on reset timing .....13

Fig 6. Power-up and reset sequence required before the ULPI bus is ready for use.....14

Fig 7. Interface behavior with respect to RESET\_N.....15

Fig 8. Interface behavior with respect to chip select...16

Fig 9. V<sub>BUS</sub> pin internal pull-up and pull-down scheme .19

Fig 10. Interface behavior when entering UART mode...28

Fig 11. Interface behavior when exiting UART mode...28

Fig 12. Single and back-to-back RXCMDs from the ISP1705 to the link.....32

Fig 13. RXCMD A\_VBUS\_VLD indicator source.....34

Fig 14. Example of register write, register read, extended register write and extended register read.....36

Fig 15. USB reset and high-speed detection handshake (chirp) sequence .....38

Fig 16. Example of using the ISP1705 to transmit and receive USB data.....39

Fig 17. High-speed transmit-to-transmit packet timing...40

Fig 18. High-speed receive-to-transmit packet timing...41

Fig 19. Preamble sequence.....42

Fig 20. Full speed suspend and resume .....43

Fig 21. High speed suspend and resume .....45

Fig 22. Remote wake-up from low-power mode .....47

Fig 23. Transmitting USB packets without automatic SYNC and EOP generation .....48

Fig 24. Example of transmit followed by receive in 6-pin serial mode .....50

Fig 25. Example of transmit followed by receive in 3-pin serial mode .....50

Fig 26. Rise time and fall time .....72

Fig 27. Timing of TX\_DAT and TX\_SE0 to DP and DM...72

Fig 28. Timing of TX\_ENABLE to DP and DM.....72

Fig 29. Timing of DP and DM to RX\_RCV, RX\_DP and RX\_DM .....72

Fig 30. ULPI timing interface .....73

Fig 31. ISP1705 in peripheral-only application .....74

Fig 32. ISP1705 in OTG application .....75

Fig 33. ISP1705 in host application .....76

Fig 34. Package outline SOT818-1 (HVQFN36) .....77

Fig 35. Package outline SOT912-1 (TFBGA36).....78

Fig 36. Temperature profiles for large and small components .....81



27. Contents

<b>1</b>	<b>General description</b> . . . . .	<b>1</b>	8.12.15	STP	20
<b>2</b>	<b>Features</b> . . . . .	<b>1</b>	8.12.16	NXT	20
<b>3</b>	<b>Applications</b> . . . . .	<b>3</b>	8.12.17	CLOCK	21
<b>4</b>	<b>Ordering information</b> . . . . .	<b>3</b>	8.12.18	CFG1, CFG2	21
<b>5</b>	<b>Marking</b> . . . . .	<b>3</b>	8.12.19	CHIP_SEL, CHIP_SEL_N	21
<b>6</b>	<b>Block diagram</b> . . . . .	<b>4</b>	8.12.20	GND	21
<b>7</b>	<b>Pinning information</b> . . . . .	<b>5</b>	<b>9</b>	<b>Modes of operation</b> . . . . .	<b>22</b>
7.1	Pinning . . . . .	5	9.1	Power modes . . . . .	22
7.2	Pin description . . . . .	6	9.1.1	Normal mode . . . . .	22
<b>8</b>	<b>Functional description</b> . . . . .	<b>9</b>	9.1.2	Power-down mode . . . . .	22
8.1	ULPI interface controller . . . . .	9	9.2	ULPI modes . . . . .	23
8.2	USB serializer and deserializer . . . . .	9	9.2.1	Synchronous mode . . . . .	23
8.3	Hi-Speed USB (USB 2.0) ATX . . . . .	9	9.2.2	Low-power mode . . . . .	24
8.4	Voltage regulator . . . . .	10	9.2.3	6-pin full-speed or low-speed serial mode . . . . .	25
8.5	Crystal oscillator and PLL . . . . .	10	9.2.4	3-pin full-speed or low-speed serial mode . . . . .	25
8.6	UART buffer . . . . .	10	9.2.5	Transparent UART mode . . . . .	26
8.7	OTG module . . . . .	11	9.3	USB state transitions . . . . .	29
8.7.1	ID detector . . . . .	11	<b>10</b>	<b>Protocol description</b> . . . . .	<b>31</b>
8.7.2	V <sub>BUS</sub> comparators . . . . .	11	10.1	ULPI references . . . . .	31
8.7.2.1	V <sub>BUS</sub> valid comparator . . . . .	11	10.2	TXCMD . . . . .	31
8.7.2.2	Session valid comparator . . . . .	11	10.3	RXCMD . . . . .	31
8.7.2.3	Session end comparator . . . . .	11	10.3.1	Linestate encoding . . . . .	32
8.7.3	SRP charge and discharge resistors . . . . .	12	10.3.2	V <sub>BUS</sub> state encoding . . . . .	33
8.8	Port power control . . . . .	12	10.3.3	Using and selecting the V <sub>BUS</sub> state encoding . . . . .	34
8.9	Band gap reference voltage . . . . .	12	10.3.3.1	Standard USB host controllers . . . . .	34
8.10	Power-On Reset (POR) . . . . .	12	10.3.3.2	Standard USB peripheral controllers . . . . .	35
8.11	Power-up, reset and bus idle sequence . . . . .	13	10.3.3.3	OTG devices . . . . .	35
8.11.1	Interface protection . . . . .	15	10.3.4	RxEvent encoding . . . . .	35
8.11.2	Interface behavior with respect to RESET_N . . . . .	15	10.3.4.1	RxActive . . . . .	35
8.11.3	Interface behavior with respect to chip select . . . . .	15	10.3.4.2	RxError . . . . .	36
8.12	Detailed description of pins . . . . .	16	10.3.4.3	HostDisconnect . . . . .	36
8.12.1	DATA[7:0] . . . . .	16	10.4	Register read and write operations . . . . .	36
8.12.2	V <sub>CC(I/O)</sub> . . . . .	16	10.5	USB reset and high-speed detection handshake (chirp) . . . . .	36
8.12.3	RREF . . . . .	17	10.6	USB packet transmit and receive . . . . .	39
8.12.4	DP and DM . . . . .	17	10.6.1	USB packet timing . . . . .	39
8.12.5	CFG0 . . . . .	17	10.6.1.1	ISP1705 pipeline delays . . . . .	39
8.12.6	V <sub>CC</sub> . . . . .	17	10.6.1.2	Allowed link decision time . . . . .	39
8.12.7	ID . . . . .	17	10.7	Preamble . . . . .	41
8.12.8	FAULT . . . . .	17	10.8	USB suspend and resume . . . . .	42
8.12.9	REG3V3 and REG1V8 . . . . .	18	10.8.1	Full-speed or low-speed host-initiated suspend and resume . . . . .	42
8.12.10	V <sub>BUS</sub> . . . . .	18	10.8.2	High speed suspend and resume . . . . .	43
8.12.11	PSW_N . . . . .	19	10.8.3	Remote wake-up . . . . .	46
8.12.12	XTAL1 and XTAL2 . . . . .	19	10.9	No automatic SYNC and EOP generation (optional) . . . . .	47
8.12.13	DIR . . . . .	20	10.10	On-The-Go operations . . . . .	48
8.12.14	RESET_N . . . . .	20			

continued >>

10.10.1	OTG comparators . . . . .	49
10.10.2	Pull-up and pull-down resistors. . . . .	49
10.10.3	ID detection. . . . .	49
10.10.4	V <sub>BUS</sub> charge and discharge resistors . . . . .	49
10.11	Serial modes. . . . .	49
10.12	Aborting transfers . . . . .	51
10.13	Avoiding contention on the ULPI data bus . . . . .	51
<b>11</b>	<b>Register map . . . . .</b>	<b>52</b>
11.1	VENDOR_ID_LOW register . . . . .	52
11.2	VENDOR_ID_HIGH register. . . . .	52
11.3	PRODUCT_ID_LOW register . . . . .	53
11.4	PRODUCT_ID_HIGH register . . . . .	53
11.5	FUNC_CTRL register . . . . .	53
11.6	INTF_CTRL register . . . . .	55
11.7	OTG_CTRL register . . . . .	56
11.8	USB_INTR_EN_R register . . . . .	58
11.9	USB_INTR_EN_F register . . . . .	58
11.10	USB_INTR_STAT register. . . . .	59
11.11	USB_INTR_L register. . . . .	59
11.12	DEBUG register . . . . .	60
11.13	SCRATCH register . . . . .	61
11.14	CARKIT_CTRL register . . . . .	61
11.15	PWR_CTRL register. . . . .	62
<b>12</b>	<b>Limiting values. . . . .</b>	<b>63</b>
<b>13</b>	<b>Recommended operating conditions. . . . .</b>	<b>63</b>
<b>14</b>	<b>Static characteristics. . . . .</b>	<b>64</b>
<b>15</b>	<b>Dynamic characteristics . . . . .</b>	<b>69</b>
<b>16</b>	<b>Application information. . . . .</b>	<b>73</b>
<b>17</b>	<b>Package outline . . . . .</b>	<b>77</b>
<b>18</b>	<b>Soldering of SMD packages . . . . .</b>	<b>79</b>
18.1	Introduction to soldering . . . . .	79
18.2	Wave and reflow soldering . . . . .	79
18.3	Wave soldering . . . . .	79
18.4	Reflow soldering . . . . .	80
<b>19</b>	<b>Abbreviations. . . . .</b>	<b>81</b>
<b>20</b>	<b>Glossary . . . . .</b>	<b>82</b>
<b>21</b>	<b>References . . . . .</b>	<b>82</b>
<b>22</b>	<b>Revision history. . . . .</b>	<b>83</b>
<b>23</b>	<b>Legal information. . . . .</b>	<b>84</b>
23.1	Data sheet status . . . . .	84
23.2	Definitions . . . . .	84
23.3	Disclaimers . . . . .	84
23.4	Trademarks . . . . .	84
<b>24</b>	<b>Contact information. . . . .</b>	<b>84</b>
<b>25</b>	<b>Tables . . . . .</b>	<b>85</b>
<b>26</b>	<b>Figures . . . . .</b>	<b>87</b>
<b>27</b>	<b>Contents . . . . .</b>	<b>88</b>

Please be aware that important notices concerning this document and the product(s) described herein, have been included in section 'Legal information'.



© NXP B.V. 2008.

All rights reserved.

For more information, please visit: <http://www.nxp.com>  
 For sales office addresses, please send an email to: [salesaddresses@nxp.com](mailto:salesaddresses@nxp.com)

Date of release: 13 June 2008  
 Document identifier: ISP1705\_1