

Features

- 2.5 to 5.5V supply voltage operating range.
- Low current consumption: 1mA in operation,
- 50 kHz or 100kHz operation frequency .
- Built-in maximum duty control.
- Push-pull output.
- Built-in soft start circuit.
- Built-in auto-discharge function.

Applications

- Digital Still Cameras flash unit

General Description

The AT1453 is a charger control IC for Photoflash capacitor with soft start function, adjustable maximum duty cycle and auto-discharge (soft start capacitor) circuit. Adjustable soft start is programmed with an external capacitor on SS pin. The control technique allows for the use of external resistor to change the switching duty and use of transformer to control the input current. A logic high on the CHARGE pin initiates charging, while the READY pin signals that the capacitor is fully charged. It is ideal for DSC flash unit.

Block Diagram

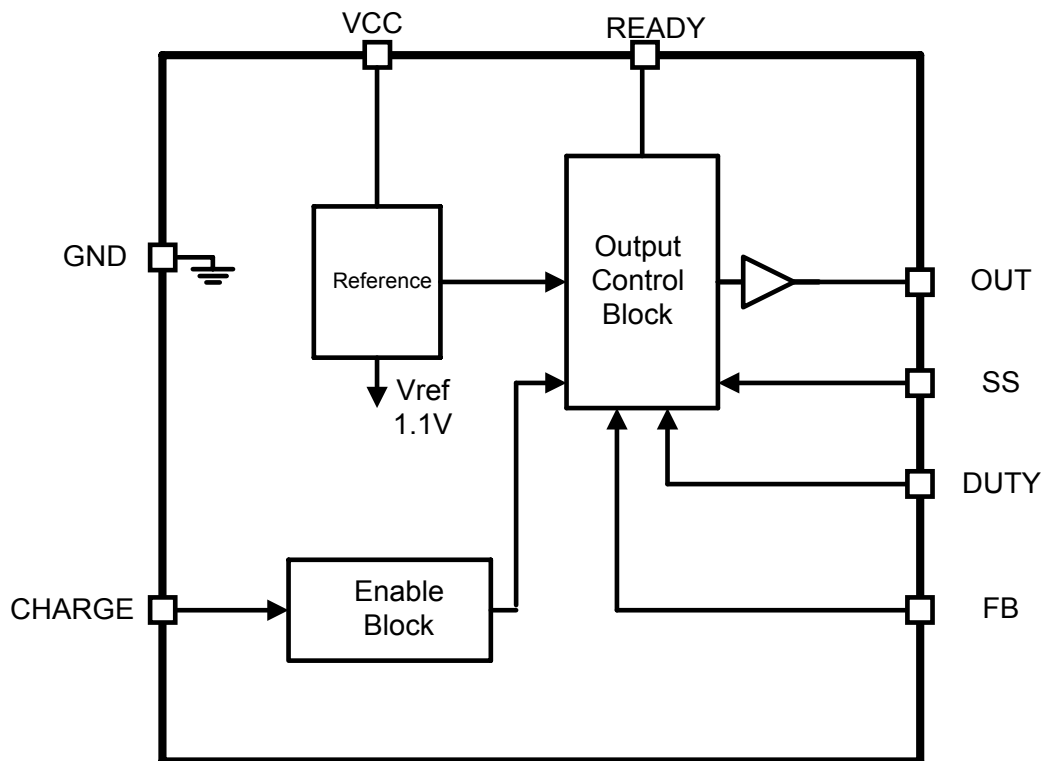

Aimtron reserves the right without notice to change this circuitry and specifications.

Pin Configuration

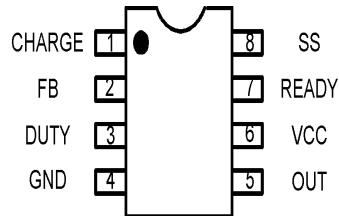

Ordering Information

Part number	Package	Remarks
AT1453A	8-pin Plastic SOP	AT1453AS
	8-pin Plastic TSSOP	AT1453AP
AT1453B	8-pin Plastic SOP	AT1453BS
	8-pin Plastic TSSOP	AT1453BP

A:50kHz B:100kHz

Pin Description

Pin No.	Symbol	I/O	Description
1	CHARGE	I	Charge enable input
2	FB	I	Error amplifier input
3	DUTY	I	Duty control input
4	GND	-	Ground
5	OUT	O	Push-pull output
6	VCC	-	Power supply
7	READY	O	Charge ready open drain output
8	SS	I	Soft-start setting

Absolute Maximum Ratings

Parameter	Condition	Rated Value		Unit
		Min.	Max.	
Power Supply Voltage	—	-	+7	V
Source Average Current of OUT	—	-	-50	mA
Sink Average Current of OUT	—	-	50	mA
Input Voltage to Error Amplifier	—	-	6.5	V
Continuous power dissipation	TSSOP8 (T _a =+25°C)	-	450	mW
	SOP8 (T _a =+25°C)	-	500	mW
Operating temperature	—	-30	+85	°C
Junction temperature	—	-	+125	°C
Storage temperature	—	-40	+150	°C
Lead temperature	—	-	+300	°C

Stresses beyond those listed under “Absolute Maximum Ratings” may cause permanent damage to the device. These are stress ratings only, and functional operation of the device at these or any other conditions beyond those indicated in the operational sections of the specifications is not implied. Exposure to absolute maximum rating conditions for extended periods may affect device reliability.

Recommended Operating Conditions

(T_a=+25°C)

Parameter	Symbol	Values			Unit
		Min.	Typ.	Max.	
Power supply voltage	V _{CC}	2.5	--	5.5	V
Operating temperature	T _{OP}	-30	+25	+85	°C

Electrical Characteristics

(VCC = 3.3V, T_a = +25°C, unless otherwise noted.)

Parameter	Symbol	Condition	Values			Unit	
			Min.	Typ.	Max.		
Entire device	Input Supply Range	V _{CC}	2.5	--	5.5	V	
	Feedback Voltage	V _{FB}	T _a = +25°C	1.080	1.100	1.120	V
	Reference variation with Temperature		T _a = -30°C to +85°C	-2	-	2	%
	Feedback Voltage line-regulation	V _{FB-Line}	VCC=2.5V to 5.5V	-5	1	5	mV
	Standby current	I _{CCS}	CHARGE=GND	-	-	400	μA
	Operating Current	I _{CC}	Duty=50%, f _{OSC} =50KHz	-	1.0	-	mA
Oscillator	Frequency	fosc	A	40	50	60	kHZ
		B	90	100	110	kHZ	
Soft-Start and Duty Section	Threshold voltage of SS	V _{SS_0}	Duty Cycle=0%	-	0.3	-	V
	Threshold voltage of SS	V _{SS_100}	Duty Cycle=100%	-	1.1	-	V
	Charging current	I _{SS}	V _{SS} =0V	0.7	1.0	1.5	μA
	Maximum duty cycle	T _{DUTY}		--	--	90	%
Output Section	Output source current	I _{SOURCE}	Duty ≥ 95%, OUT=0V	-	-130	-80	mA
	Output sink current	I _{SINK}	Duty ≤ 5%, OUT=5V	65	100	-	mA
	Output ON resistor	R _{OH}	OUT = -15mA	-	18	30	Ω
	Output OFF resistor	R _{OL}	OUT = 15mA	-	16	25	Ω
Charge ON/OFF Section	Active mode Threshold	V _{ONH}		2.0			V
	Disable mode Threshold	V _{ONL}				0.8	V

Timing Chart

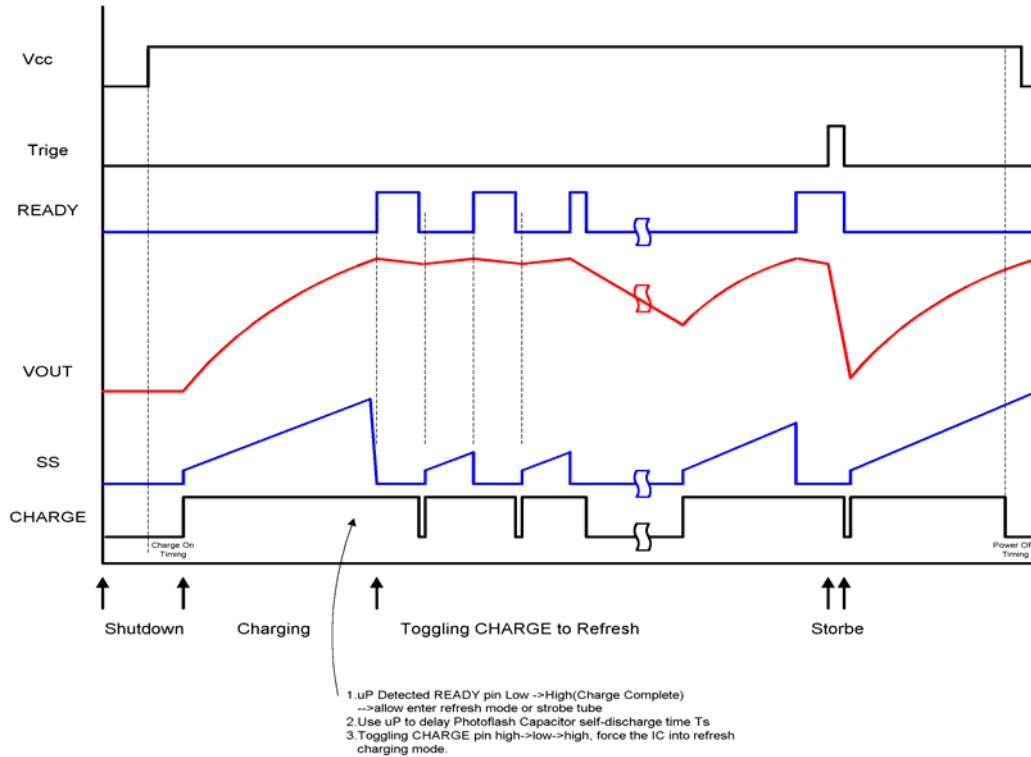

AT1453 Charge Toggling Refresh Mode

DUTY Setting

The DUTY resistor selection depends on Duty Cycle , choose the component using the following equation:

$$V_{DUTY} (V) = 0.3 + \frac{DUTY}{1.15}$$
$$R_{DUTY} (K\Omega) = \frac{15}{\left(\frac{1.1}{V_{DUTY}}\right) - 1.073}$$

example:

Set duty cycle is 50%

$$V_{DUTY} = 0.3 + \frac{0.5}{1.15} = 0.734$$
$$R_{DUTY} = \frac{15}{\left(\frac{1.1}{0.734}\right) - 1.073} \approx 35.2K\Omega$$

Output Voltage Setting

$$V_{DUTY} = \frac{R1 + R2}{R2} \times V_{FB}$$

$$V_{FB} = 1.1V$$

Typical Curve

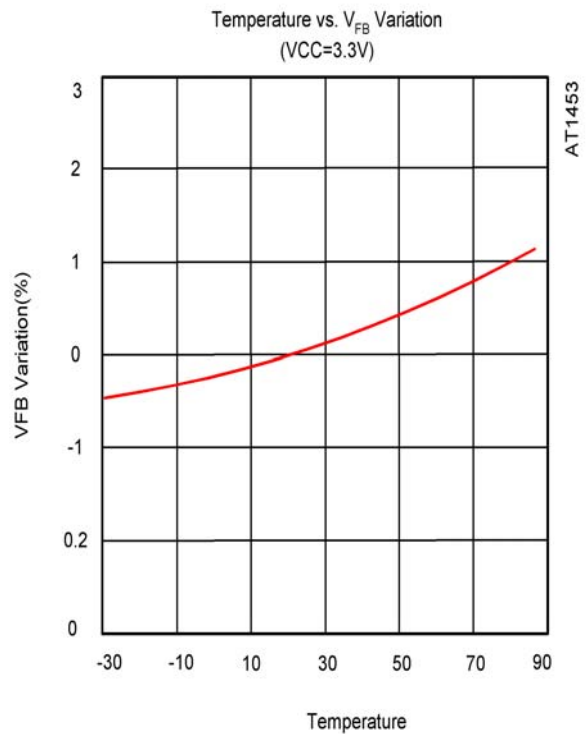
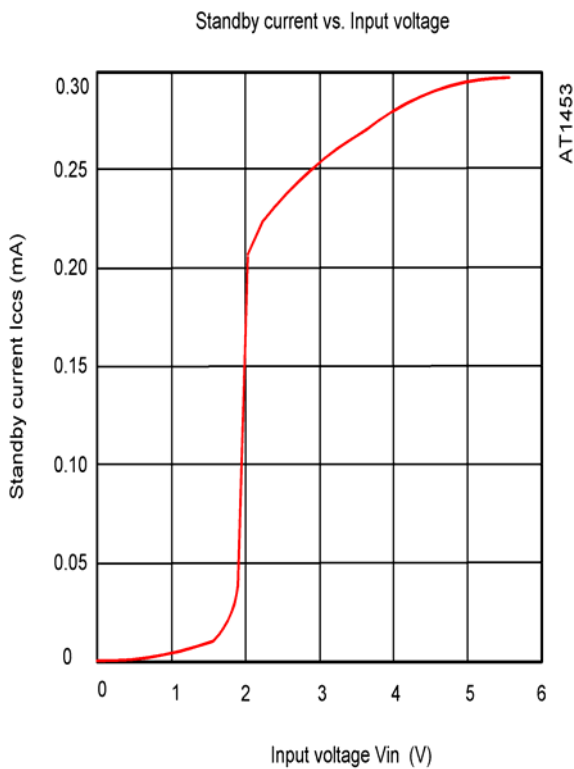
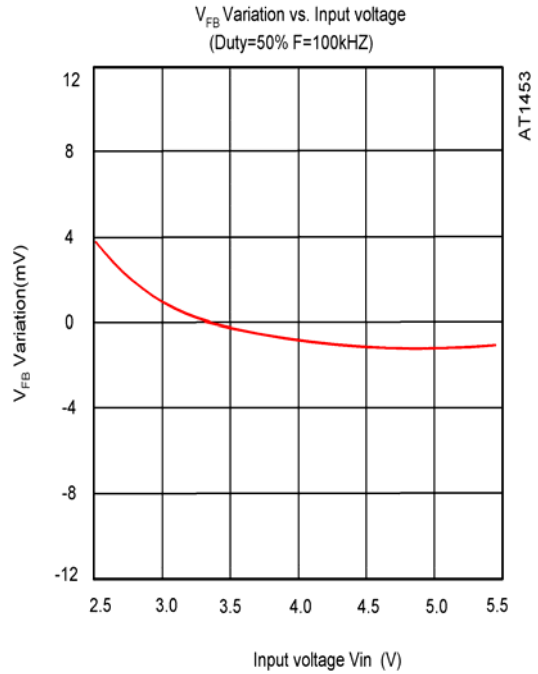
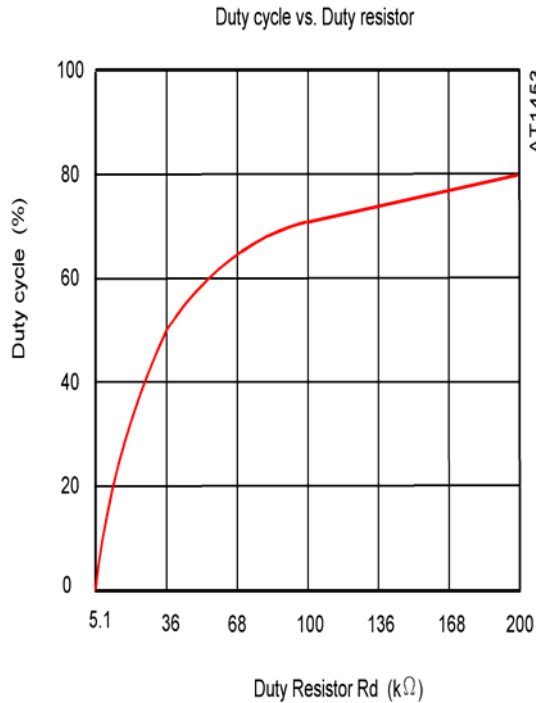

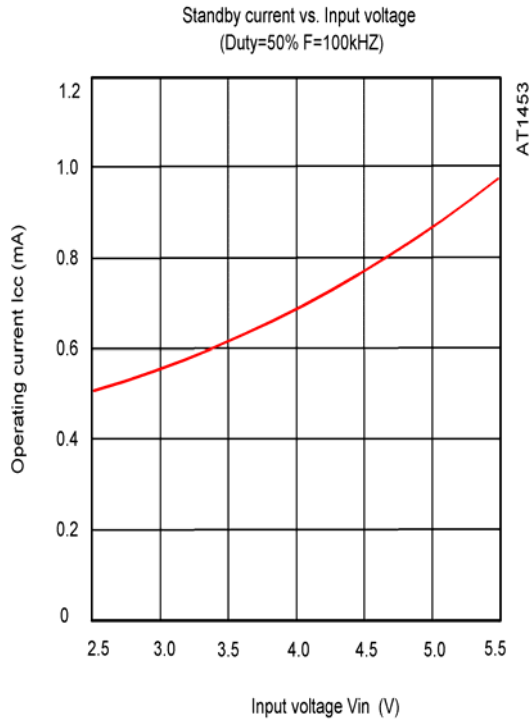

Typical Application Schematic
(A) IGBT Trigger

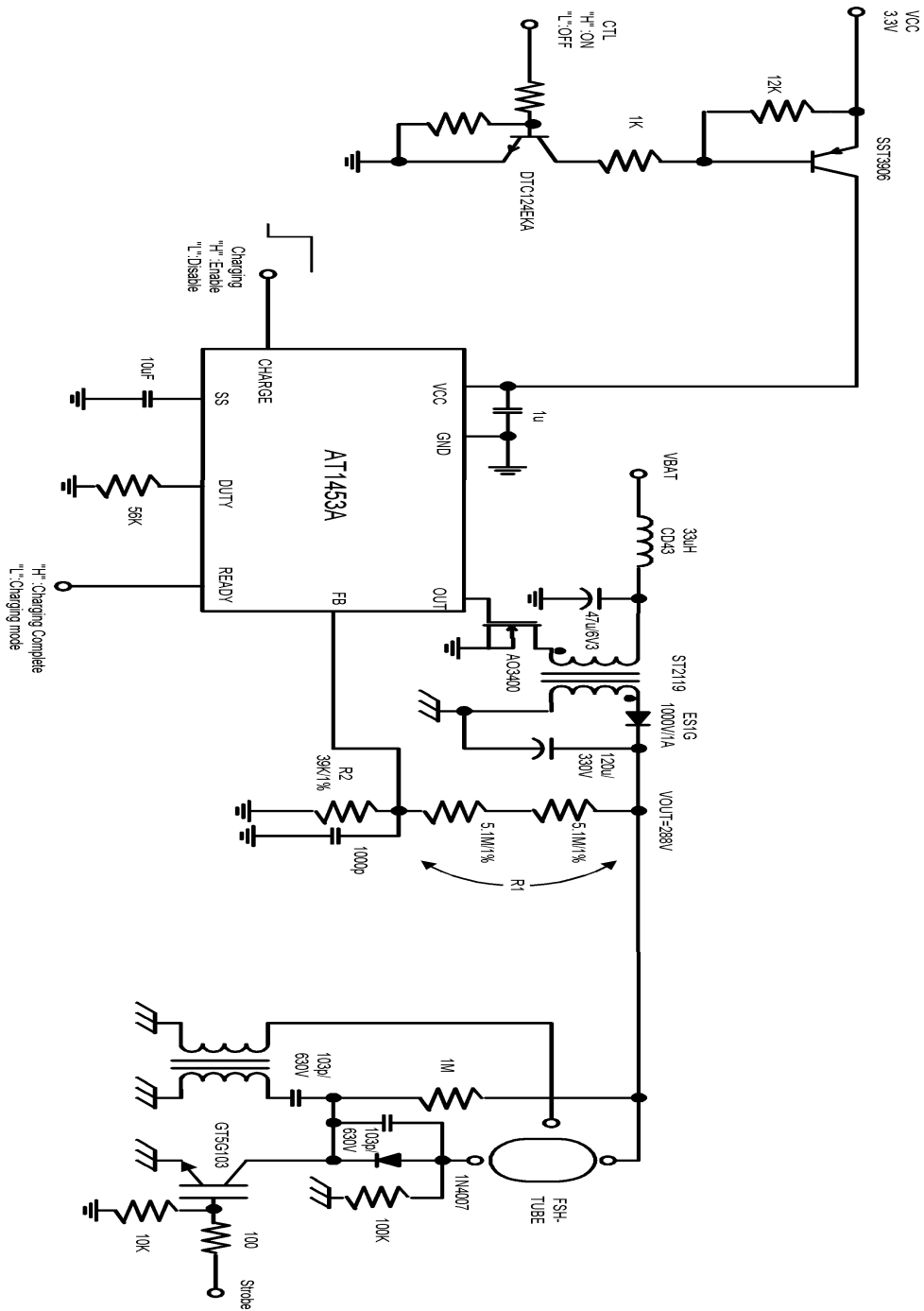

(B) SCR Trigger

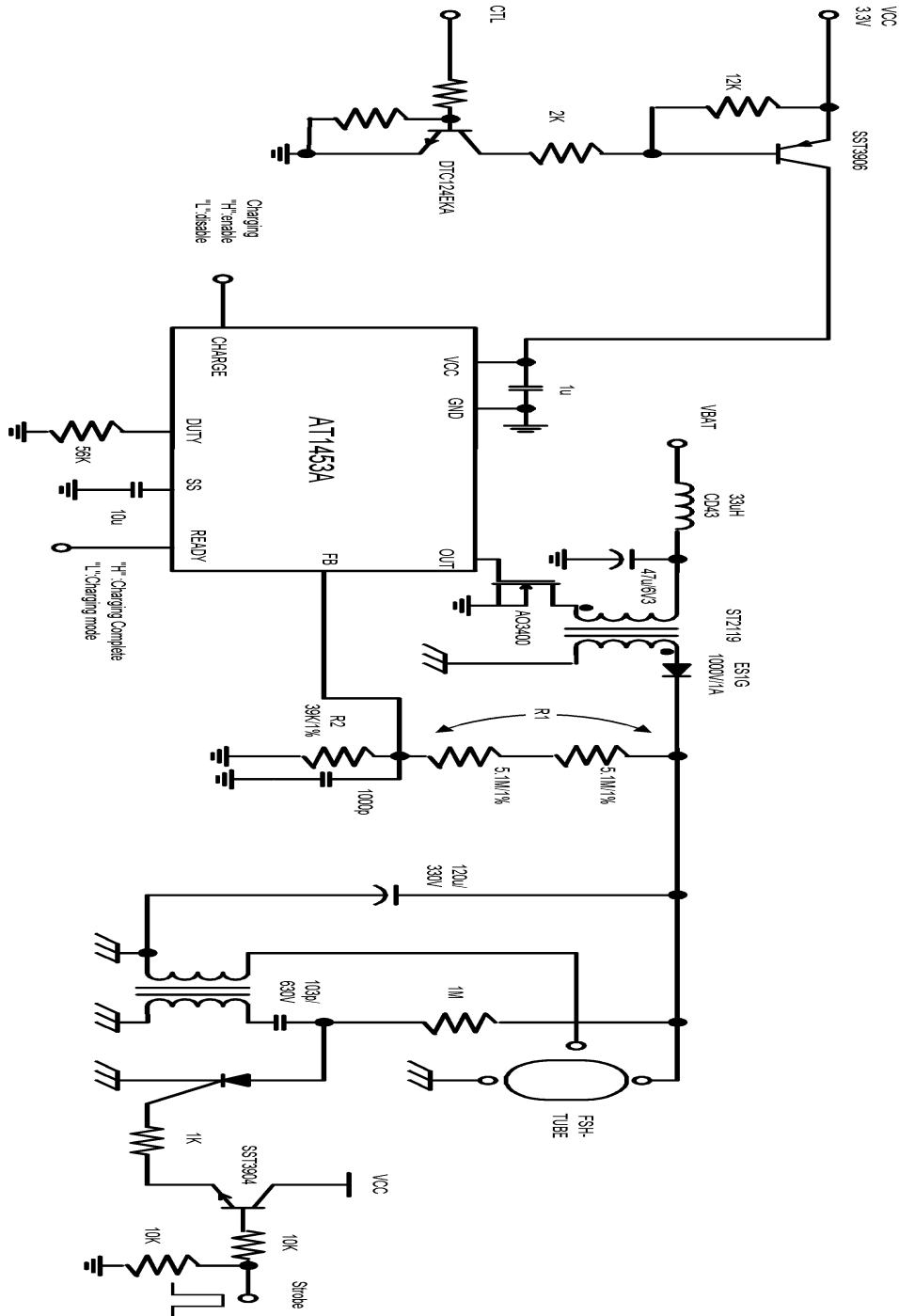

(C) Li-Ion Application

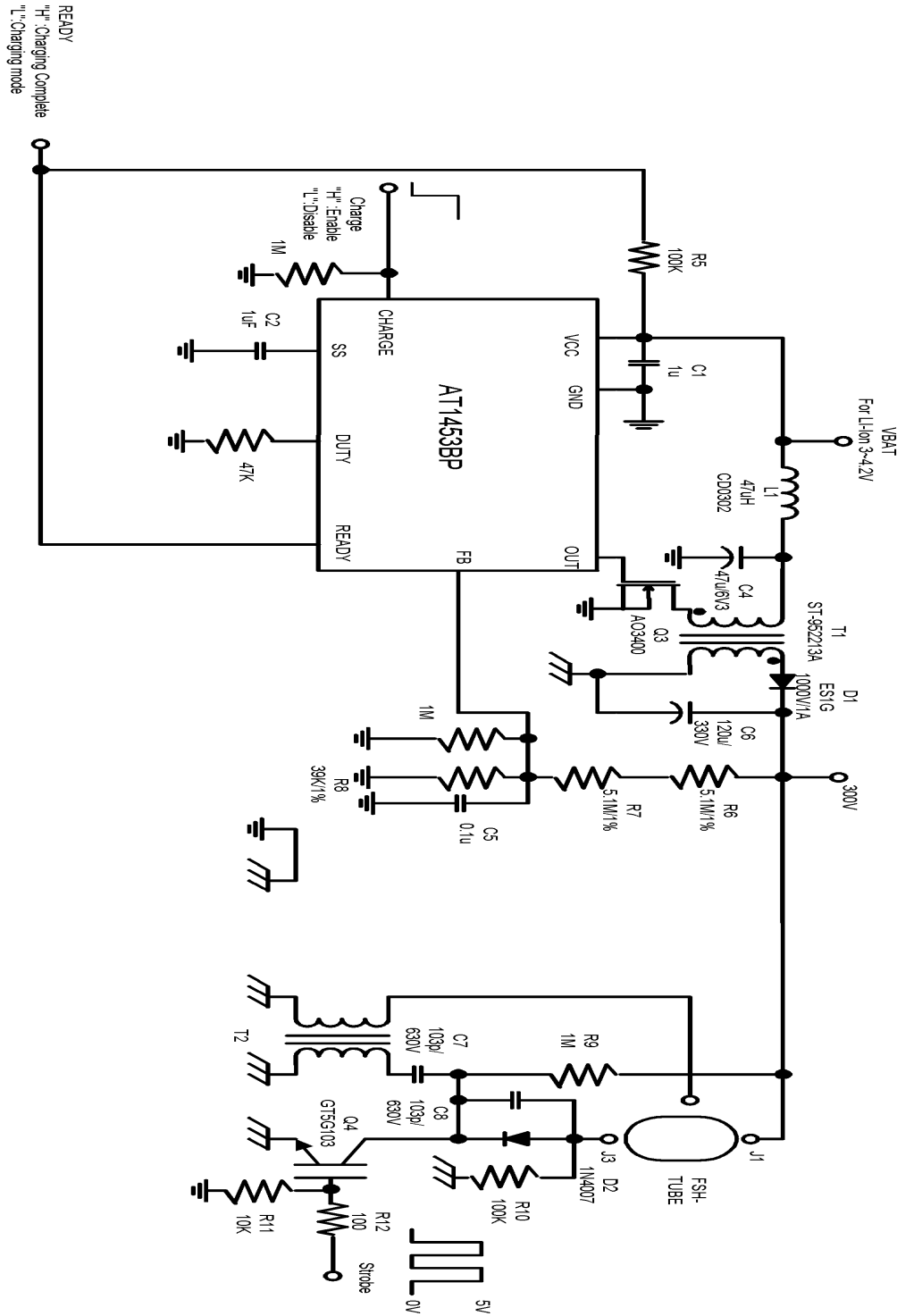

CH1:CHARGE CH2:READY CH3:V_{OUT}(300V) CH4:IBAT

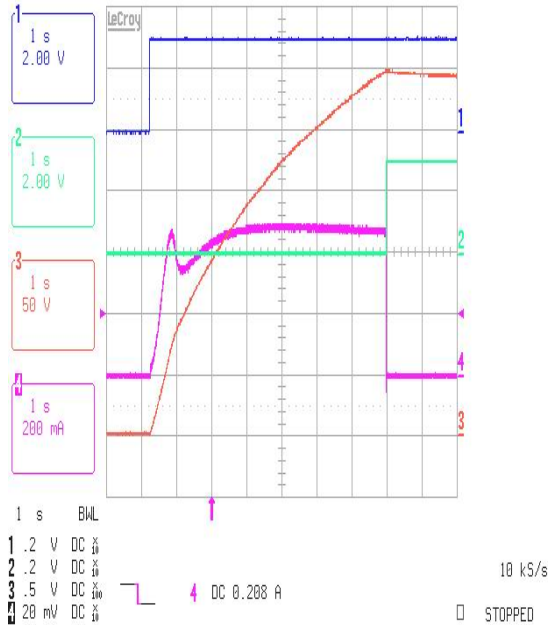

Fig 1. VBAT=3.0V

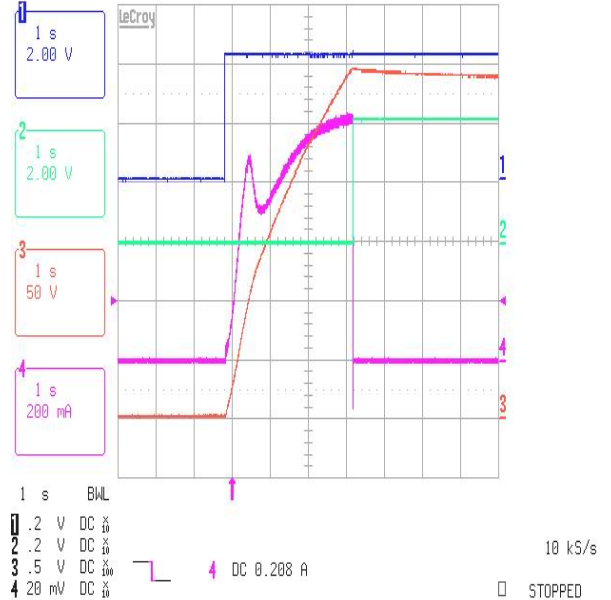

Fig 3. VBAT=4.2V

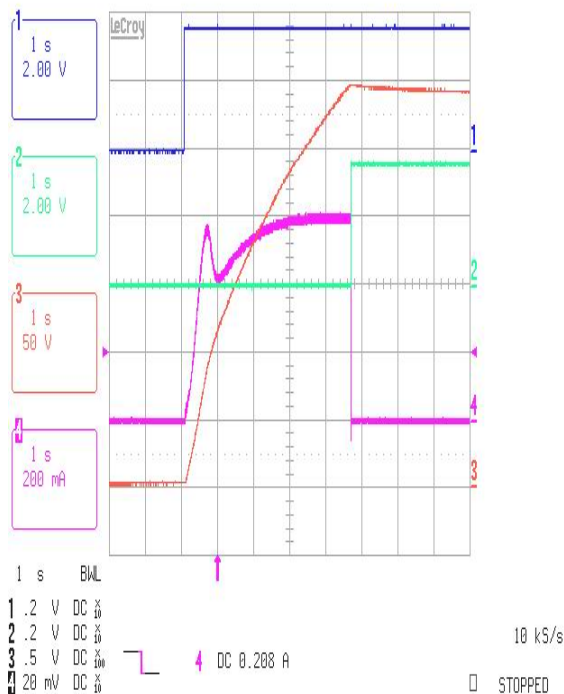
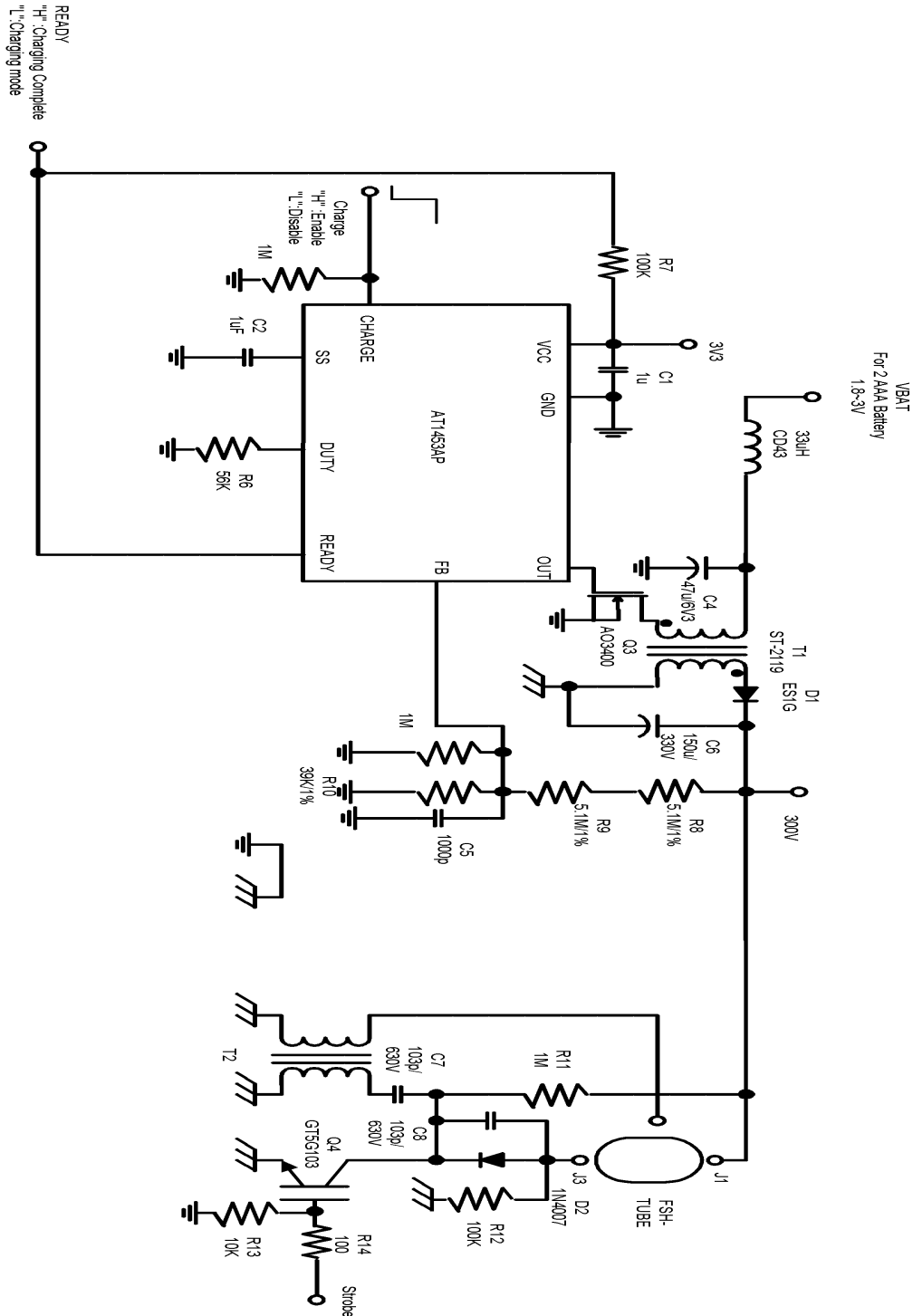

Fig 2. VBAT=3.6V

VBAT	Charge Time	Charge Input Current
3.0V	6.79s	500mA
3.6V	4.62s	600mA
4.2V	3.36s	800mA

* RDUTY can be change the Input Current.

(D) 2-Cell Battery Application



CH1:CHARGE CH2:READY CH3:V_{OUT}(300V) CH4:IBAT

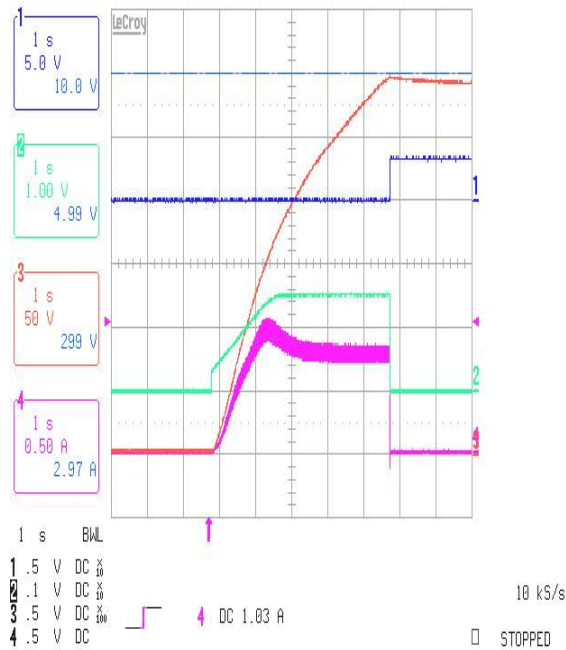

Fig 4. VBAT=2.0V

V _{BAT}	Charge Time	Charge Input Current
3.0V	4.79s	800mA
2.0V	13.6s	500mA

* RDUTY can be change the Input Current.

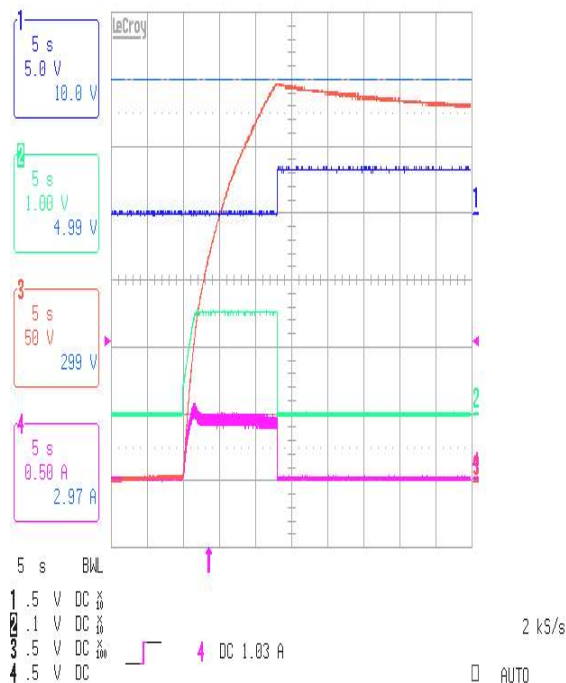
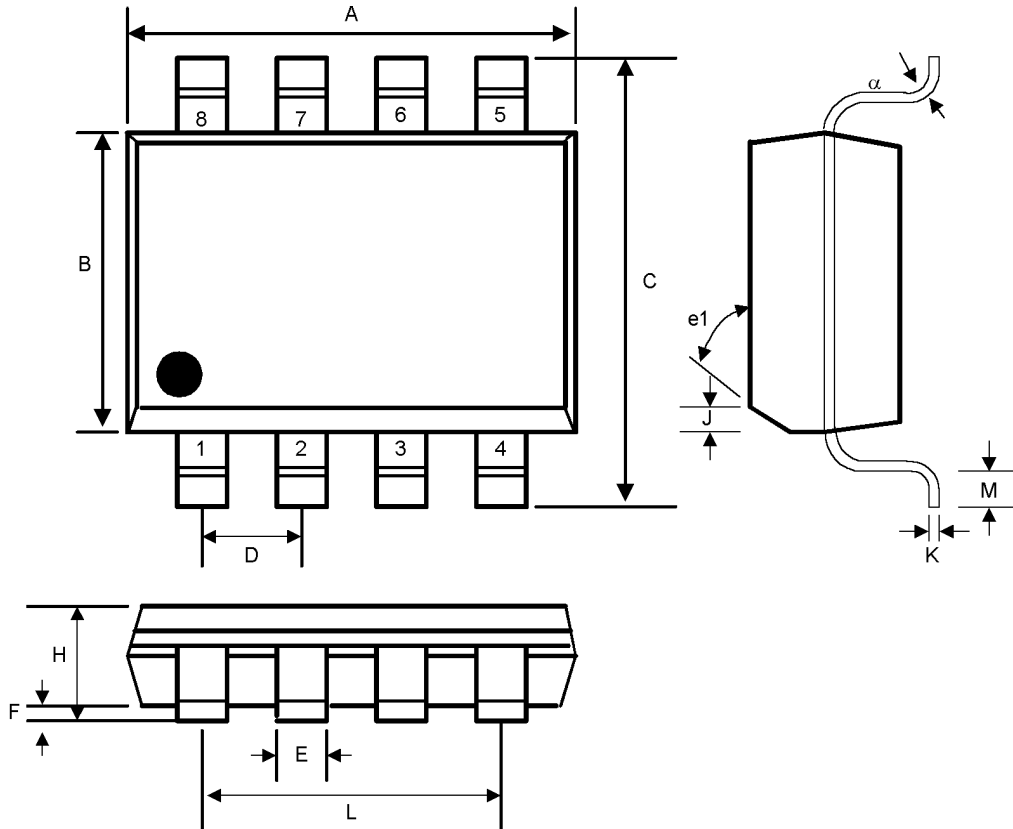

Fig 5. VBAT=3.0V

Small Outline 8-pin Plastic SOL



SYMBOL	INCHES		MILLIMETERS		NOTES
	MIN	MAX	MIN	MAX	
A	0.188	0.197	4.80	5.00	-
B	0.149	0.158	3.80	4.00	-
C	0.228	0.244	5.80	6.20	-
D	0.050	BSC	1.27	BSC	-
E	0.013	0.020	0.33	0.51	-
F	0.004	0.010	0.10	0.25	-
H	0.053	0.069	1.35	1.75	-
J	0.011	0.019	0.28	0.48	-
K	0.007	0.010	0.19	0.25	-
M	0.016	0.050	0.40	1.27	-
L	0.150	REF	3.81	REF	-
e1	45°		45°		-
α	0°	8°	0°	8°	-

Small Outline 8-pin TSSOP

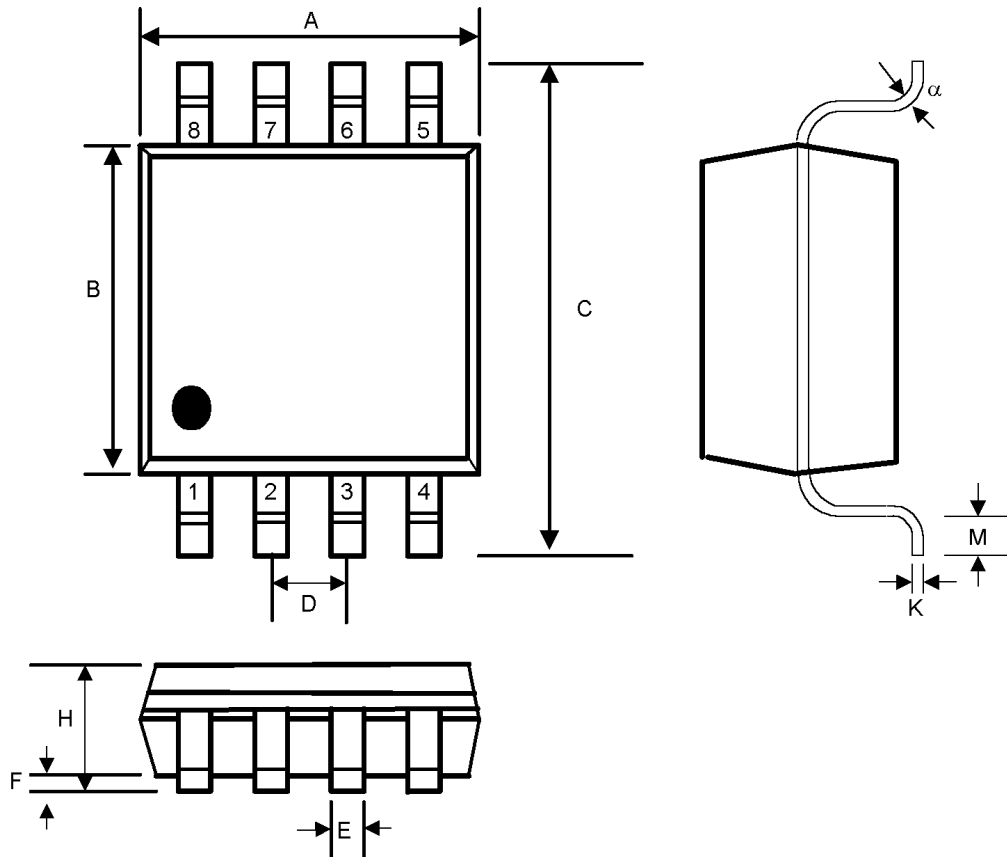

SYMBOL	INCHES		MILLIMETERS		NOTES
	MIN	MAX	MIN	MAX	
A	0.114	0.122	2.90	3.10	-
B	0.169	0.177	4.30	4.50	-
C	0.244	0.260	6.20	6.60	-
D	0.026	BSC	0.65	BSC	-
E	0.010	0.012	0.25	0.30	-
F	0.002	0.006	0.05	0.15	-
H	0.041	0.047	1.05	1.20	-
K	0.005	BSC	0.127	BSC	-
M	0.020	0.028	0.50	0.70	-
α	0°	8°	0°	8°	-

Reflow Condition (IR/Convection or VPR Reflow)

Reference JEDEC Standard J-STD-020A

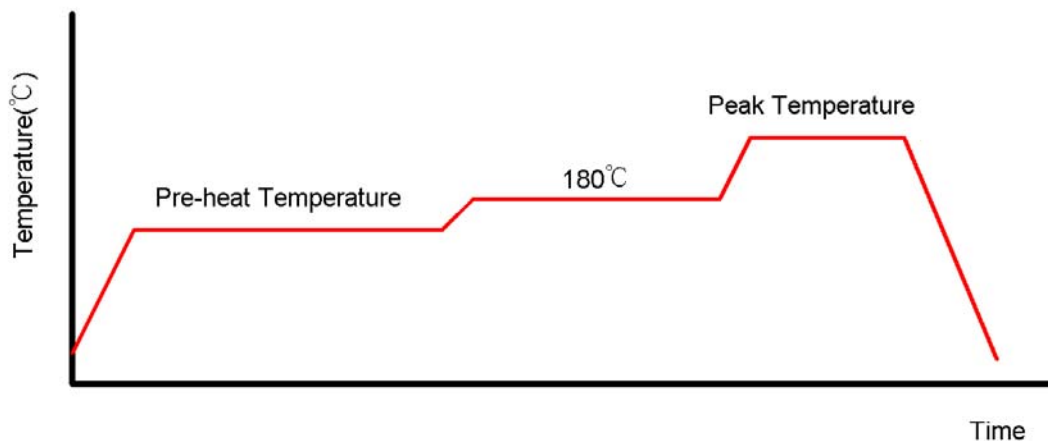

Classification Reflow Profiles

	Convection or IR/Convection	VPR
Average Heating Rate(180°C to peak)	5°C/second max.	10°C/second max.
Preheat Temperature(125±20°C)	120 seconds max.	
Temperature maintained above 180°C	10~150 seconds	
Time within 5°C of actual Peak Temperature	10~20 seconds	60 seconds
Peak Temperature Range(Note 1)	219~225°C or 235~240°C	219~225°C or 235~240°C
Cooling Rate	6°C /second max.	10°C/second max.
Time 25°C to Peak Temperature	6 minutes max.	

*1 The maximum peak temperatures for IR and VP reflow are depending on package dimensions.

Package Reflow Conditions

Pkg. Thickness ≥2.5mm and all bags	Pkg. Thickness <2.5mm and Pkg. Volume ≥350 mm ³	Pkg. Thickness <2.5mm and Pkg. Volume <350 mm ³
Convection 219~225°C		Convection 235~240°C
VPR 219~225°C		VPR 235~240°C
IR/Convection 219~225°C		IR/Convection 235~240°C