

- | | |
|-----------------------|---|
| S t r u c t u r e | Silicon monolithic integrated circuit |
| P r o d u c t n a m e | Strobe capacitor charging control IC |
| M o d e l N o . | BD4222MUV |
| F e a t u r e s | <ol style="list-style-type: none"> 1. Built-in power transistor(45V DMOS) 2. Adjustable transformer primary-side peak current to linear current with the ADJ pin 3. Charging control switching with the START pin 4. Includes high precision full charge voltage detection circuit and output pin 5. Various built-in protective circuits (TSD, UVLO) 6. Built-in protective circuits (SDP) 7. Built-in IGBT driver(VDD supply for IGBT driver) 8. Employs small package: VQFN016V3030 (3.0 mm×3.0 mm×1.0 mm) |

○ Absolute Maximum Ratings(Ta=25°C)

Parameter	Symbol	Rating	Unit
VCC supply voltage	VCC	-0.3~7	V
VDD supply voltage	VDD	-0.3~7	V
SW pin	VSW	45	V
VC pin (DC characteristic)	VCDC	-15~50	V
Input pin voltage (START, ADJ, IGBT_IN, IGBT_EN)	VI	-0.3~7	V
Operating temperature range	Topr	-35~+85	°C
Storage temperature range	Tstg	-55~+150	°C
Junction temperature	Tjmax	150	°C
Power dissipation	Pd	1770 *1	mW

○ Operating Conditions(Ta=25°C)

Parameter	Symbol	Rating	Unit
VCC supply voltage range	VCC	2.5~5.5	V
VDD supply voltage range	VDD	2.5~5.5	V
Input pin voltage (START, ADJ, IGBT_IN, IGBT_EN)	VI	0~VCC	V
FULL pin input current range	VFULL	0~5.5	V

*1: Reduced by 14.16 mW/°C at Ta=25°C or more (When mounted on a 74.2 mm×74.2 mm×1.6 mm glass epoxy, 4-layer board: Surface radiating copper foil of 6.28mm², copper foil laminated in each layer)

○ Outside marking and dimension (UNIT:mm)

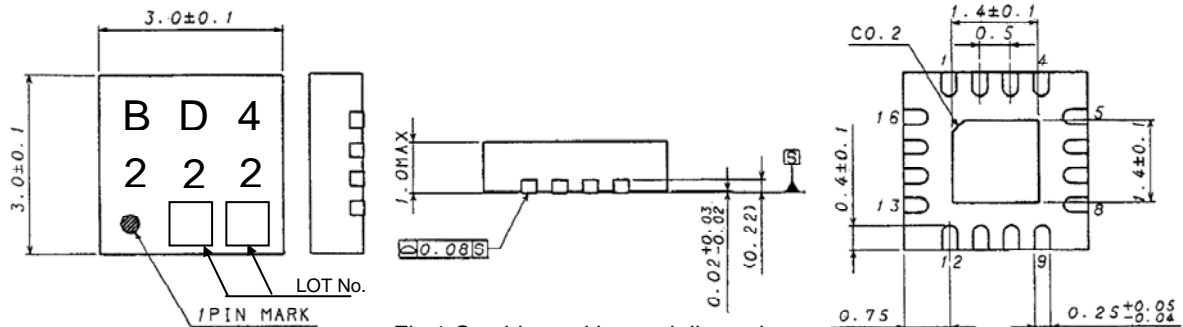

Fig.1 Outside marking and dimension

○ Electrical Characteristics (Ta=25°C,VCC=START=VDD=3.3V, VBAT=3.6V,ADJ=1.0V,unless otherwise specified.)

Parameter	Symbol	Target value			Unit	Condition
		Min.	Standard	Max.		
【Overall device】						
VCC current consumption	IVCC	—	1	2.5	mA	At Output OFF
VCC Circuit current standby operation	ISTB	—	—	1	μA	START=0V
VDD current consumption	IVDD	20	40	80	μA	IGBT_EN=3.3V,IGBT_IN=0V
VDD Circuit current standby operation	IVDDSTB	—	—	1	μA	IGBT_EN=0.0V,IGBT_IN=0V
【Standby control START pin】						
START pin high voltage	VSTH	2.0	—	—	V	
START pin low voltage	VSTL	—	—	0.6	V	
START pin sink current	ISTART	12	24	36	μA	START=3.3V
Unresponsive time when START shorted	TSTART	6	12.5	25	μs	
【Transformer primary-side driver block】						
SW pin leak current	ISWL	—	—	1	μA	SW=45V
SW pin peak current 1	IPEAK1	0.9	1.0	1.1	A	ADJ=0V
SW pin peak current 2	IPEAK2	1.5	1.6	1.7	A	ADJ=1V
SW pin peak current 3	IPEAK3	3.05	3.20	3.35	A	ADJ=3V
SW saturation voltage	VSAT	—	0.10	0.20	V	ISW=0.5A
【Charging characteristics adjustment block】						
ADJ sink current	IADJ	—	5	10	μA	
Maximum ON time	TONMAX	25	50	100	μs	
Maximum OFF time	TOFFMAX	12	25	50	μs	
【Transformer secondary-side detection block】						
VC pin sink current	IVC	1	2	4	mA	VC=30V
Full charge detection voltage	VFULLTH	29.7	30	30.3	V	
OFF detection voltage	VOFFL	-1.3	-0.5	-0.2	V	
FULL pin ON resistance	RFULL	50	110	300	Ω	FULL=0.5V
FULL pin leak current	IFULLH	—	—	1	μA	FULL=3.3V
Anti-Ringing Filter time	TVCF	100	200	320	nS	
【Protective circuit block】						
UVLO detection voltage	VUVLOTH	1.9	2.05	2.2	V	VCC detection
UVLO hysteresis width	VUVLOHYS	180	230	280	mV	
UVLO VDD detection voltage	VUVLODTH	1.9	2.05	2.2	V	VDD detection IGBT_IN=3.3V, IGBT_EN=3.3V
UVLO VDD hysteresis width	VUVLODHYS	180	230	280	mV	IGBT_IN=3.3V, IGBT_EN=3.3V
【IGBT driver block】						
High-level output short circuit current	loso	90	140	200	mA	IGBT_IN=3.3V, IGBT_EN=3.3V START=0V,IGBT_OUT_P=0V
Low-level output short circuit current	losi	30	60	90	mA	IGBT_IN=0V, IGBT_EN=3.3V START=0V,IGBT_OUT_N=3.3V
IGBT_IN high-level input voltage range1	VIGBTH1	2.0	—	—	V	IGBT_EN=3.3V, START=0V
IGBT_IN high-level input voltage range2	VIGBTH2	1.4	—	—	V	VDD=3.0~3.6V, Ta=-25~85°C, IGBT_EN=3.3V
IGBT_IN low-level input voltage range	VIGBTL	—	—	0.6	V	IGBT_EN=3.3V, START=0V
IGBT_IN sink current	IIGBT_IN	12	24	36	μA	IGBT_IN=3.3V, START=0V
IGBT_EN high-level input voltage range	VIGBTENH	2.0	—	—	V	IGBT_IN=3.3V, START=0V
IGBT_EN low-level input voltage range	VIGBTENL	—	—	0.6	V	
IGBT_EN sink current	IIGBT_EN	4.5	6.5	10	μA	IGBT_EN=3.3V, IGBT_IN=3.3V

○ PIN No.

Pin No.	Pin Name	Function
1	VDD	VDD supply pin
2	VCC	VCC supply pin
3	GND	Ground pin
4	ADJ	primary-side current control pin
5	FULL	FULL charge detection flag pin
6	START	Standby pin
7	VC	Secondary-side voltage detection pin
8~10	SW	Switching pin
11,12	PGND	Power GND pin
13	IGBT_IN	input terminal of trigger signal for starting output of IGBT driver
14	IGBT_EN	input terminal of control enable signal of IGBT driver
15	IGBT_OUT_N	IGBT driver output N pin
16	IGBT_OUT_P	IGBT driver output P pin

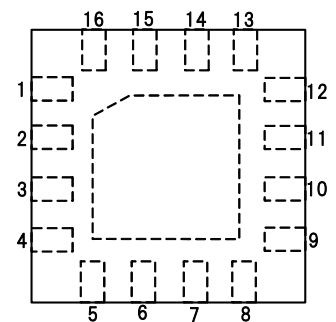

Fig.3 TOP VIEW

○ Blok Diagram

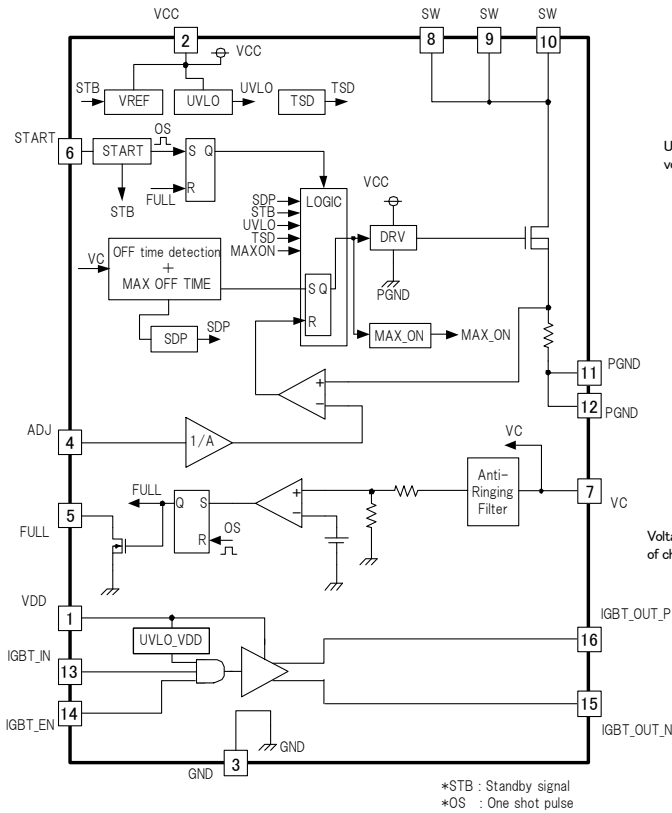

Fig.3 Block diagram

○ UVLO, TSD, SDP

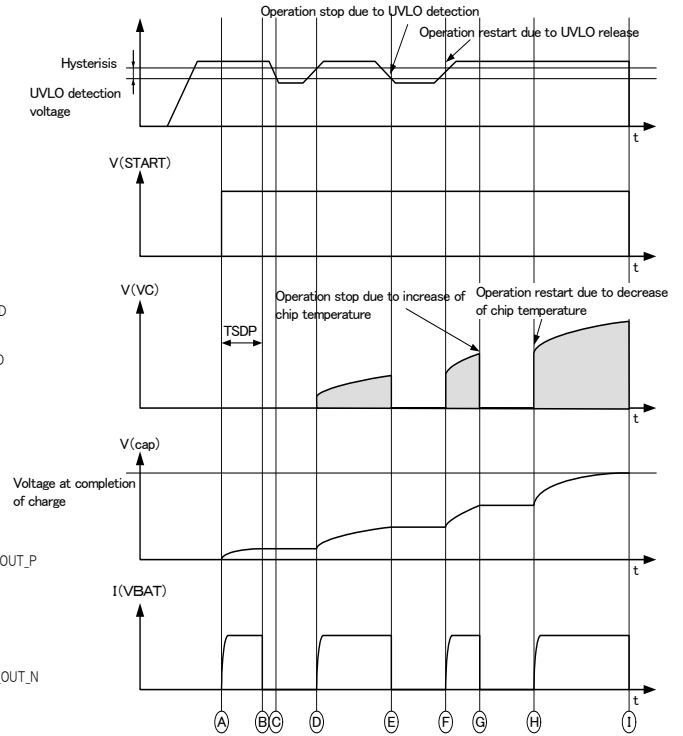

Fig.4 Timing Chart: Under Protective Circuit Operation

◆UVLO

If the VCC voltage is reduced to the UVLO detection voltage specified in the electrical characteristics or less, the UVLO protective circuit is activated and the charging operation temporarily stops. (See Time ㉔ and ㉕ in Fig.4.) After that, when the VDD voltage becomes the UVLO release voltage or more, the charging operation automatically restarts. (See Time ㉖ and ㉗ in Fig.4.)

◆VDD UVLO

If the VDD voltage becomes the VDD UVLO detection voltage or less, the IGBT_OUT voltage is forced to be set to "L".

◆Termal Shut Down (TSD)

It protects the IC against thermal runaway due to excessive temperature rise ($T_j > 190^\circ\text{C}$ [TYP]). After detection, the charging operation temporarily stops (See time ㉔ in Fig.4.), and when the chip temperature decreases, ($T_j < 165^\circ\text{C}$ [TYP]), it automatically restarts. (See Time ㉕ in Fig.4.)

◆VC pin short detection (SDP)

If the VC pin becomes the GND level due to any failure and the PowerMOS repeats switching $2^{16}(=65536)$ times which is the SDP count number (TSDP) at the maximum OFF time, it is judged as an error and the charging operation is forced to be stopped. (See Time ㉔ in Fig.4.) If the START pin is changed from "L" to "H" and the UVLO detection is released, it restarts.

○ Precautions for Use

1. Absolute Maximum Rating

Although we pay due attention to the quality control of these products, the possibility of deterioration or destruction may exist when impressed voltage, operating temperature range, etc., exceed the absolute maximum rating. In addition, it is impossible to assume a destructive situation, such as short circuit mode, open circuit mode, etc. If a special mode exceeding the absolute maximum rating is assumed, please review to provide physical safety means such as fuse, etc.

2. GND Potential

Maintain the PGND pin potential at the minimum level under the operating conditions. Furthermore, maintain the pin except the VC pin at a voltage higher than the PGND pin voltage including an actual transient phenomenon.

The SW pin sometimes is charged by a negative voltage depending on the characteristics of the external transformer.

If any change in or damage of electrical characteristics is suspected due to the SW pin being charged by a negative voltage, it is recommended that a schottky diode should be connected between the SW pin and the PGND pin.

3. Thermal Design

Work out the thermal design with sufficient margin taking power dissipation (Pd) at the actual operation condition into account.

4. Protective circuits

This IC don't have over current protect circuit. The threat of destruction may exist , if Pd is over caused by over current or short circuit pin . Be careful to design around circuit.

5. Short Circuit between Pins and Incorrect Mounting

Sufficient caution is required for IC direction or displacement when installing IC on PCB. If IC is installed incorrectly, it may be broken. Also, the threat of destruction may exist in short circuits caused by foreign object invasion between outputs or output and GND of the power supply.

6. Common Impedance

When providing a power supply and GND wirings, give sufficient consideration to lowering common impedance, reducing ripple (i.e. making thick and short wiring, reduction ripple by LC, etc.) as much as possible.

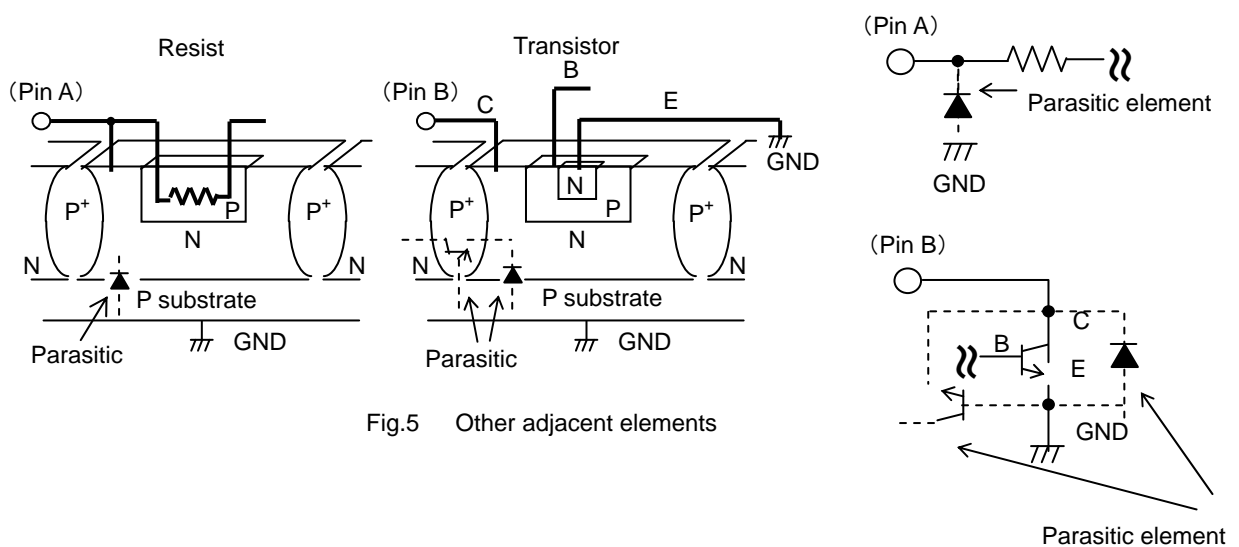

Notes

No copying or reproduction of this document, in part or in whole, is permitted without the consent of ROHM Co.,Ltd.

The content specified herein is subject to change for improvement without notice.

The content specified herein is for the purpose of introducing ROHM's products (hereinafter "Products"). If you wish to use any such Product, please be sure to refer to the specifications, which can be obtained from ROHM upon request.

Examples of application circuits, circuit constants and any other information contained herein illustrate the standard usage and operations of the Products. The peripheral conditions must be taken into account when designing circuits for mass production.

Great care was taken in ensuring the accuracy of the information specified in this document. However, should you incur any damage arising from any inaccuracy or misprint of such information, ROHM shall bear no responsibility for such damage.

The technical information specified herein is intended only to show the typical functions of and examples of application circuits for the Products. ROHM does not grant you, explicitly or implicitly, any license to use or exercise intellectual property or other rights held by ROHM and other parties. ROHM shall bear no responsibility whatsoever for any dispute arising from the use of such technical information.

The Products specified in this document are intended to be used with general-use electronic equipment or devices (such as audio visual equipment, office-automation equipment, communication devices, electronic appliances and amusement devices).

The Products specified in this document are not designed to be radiation tolerant.

While ROHM always makes efforts to enhance the quality and reliability of its Products, a Product may fail or malfunction for a variety of reasons.

Please be sure to implement in your equipment using the Products safety measures to guard against the possibility of physical injury, fire or any other damage caused in the event of the failure of any Product, such as derating, redundancy, fire control and fail-safe designs. ROHM shall bear no responsibility whatsoever for your use of any Product outside of the prescribed scope or not in accordance with the instruction manual.

The Products are not designed or manufactured to be used with any equipment, device or system which requires an extremely high level of reliability the failure or malfunction of which may result in a direct threat to human life or create a risk of human injury (such as a medical instrument, transportation equipment, aerospace machinery, nuclear-reactor controller, fuel-controller or other safety device). ROHM shall bear no responsibility in any way for use of any of the Products for the above special purposes. If a Product is intended to be used for any such special purpose, please contact a ROHM sales representative before purchasing.

If you intend to export or ship overseas any Product or technology specified herein that may be controlled under the Foreign Exchange and the Foreign Trade Law, you will be required to obtain a license or permit under the Law.



Thank you for your accessing to ROHM product informations.
More detail product informations and catalogs are available, please contact us.

ROHM Customer Support System

<http://www.rohm.com/contact/>