

STRUCTURE Silicon Monolithic Integrated Circuit

PRODUCT SERIES Strobe Charge Control IC

TYPE **BD4224NUX**

- Functions
1. Built-in Low V_{th} DMOS 45V
 2. Adjustable transformer primary-side peak current by RADJ pin
 3. Standby mode switching with the START pin.
 4. Includes charge complete signal output (FULL) pin.
Includes charge voltage detection (VC) pin (can be set externally).
 5. Built-in thermal shutdown circuit (TSD).
Built-in under voltage looked out (UVLO).
 6. Built-in transformer secondary-side OPEN, SHORT protection.
 7. SON 10pin package VSONO10X3020(3.0mm × 2.0mm × 0.6mm)

○ Absolute maximum ratings(T_a=25°C)

Parameter	Symbol	Limit	Unit
VCC pin	VCC	-0.3 to 7	V
SW pin	VSW	45	V
VC pin	VC	-0.3 to 7	V
START pin	START	-0.3 to 7	V
FULL pin	FULL	-0.3 to 7	V
IGBT_IN pin	IGBT_IN	-0.3 to 7	V
Operating temperature	T _{opr}	-35 to 85	°C
Storage temperature range	T _{stg}	-55 to 150	°C
Junction temperature	T _{jmax}	150	°C
Power dissipation	P _d	1540	mW

Reduced by 12.32 mW/°C over T_a = 25° C. (When mounted on 74.2 mm × 74.2 mm × 1.6 mm, glass epoxy)

○ Recommended operating ranges

Parameter	Symbol	Limit	Unit
VCC power supply input voltage range	VCC	2.5 to 5.5	V
VC pin input voltage range	VC	-0.3 to VCC	V
START pin input voltage range	VSTART	0 to VCC	V
IGBT_IN pin input voltage range	VIGBT_IN	0 to VCC	V
FULL pin input voltage range	VFULL	0 to 5.5	V
SW pin current	ISW	0 to 2	A

○ Electrical characteristics (Ta=25°C, VCC=V(START)=3.3 V, V(IGBT_IN)=0V)

Parameter	Symbol	Limit			Unit	Conditions
		Min.	Typ.	Max.		
[Overall device]						
VCC circuit current	ICC	—	1.5	3	mA	
Circuit current standby operation	ISTB	—	—	1	μA	START=0V
[Standby control START pin]						
START pin high voltage	VSTH	2	—	—	V	
START pin low voltage	VSTL	—	—	0.6	V	
Input bias current	ISTART	12	24	36	μA	START=3.3V
[Transformer primary-side driver block]						
SW pin leak current	ISWL	—	—	1	μA	SW=45V
SW pin peak current	IPEAK	0.4	0.5	0.6	A	RADJ=100kΩ
SW saturation voltage	VSAT	—	0.2	0.4	V	ISW=0.5A
RADJ adjustable range	RADJ	33	—	100	kΩ	
[Charging control block]						
Max on time	TONMAX	20	40	100	μs	
Max off time	TOFFMAX	10	20	50	μs	
[Transformer secondary-side detection block]						
VC pin input current	IVC	—	—	1	μA	VC=VCC
Full charge detection voltage	VFULLTH	0.989	1	1.011	V	
Full charge detection voltage AC1	VFULLTH_AC1	0.9890	1	1.0135	V	VC=200ns pulse input→FULL=H→L
Full charge detection voltage AC2	VFULLTH_AC2	0.9890	1	1.0160	V	VC=100ns pulse input→FULL=H→L
FULL pin ON resistor	RFULLL	0.5	1	2	kΩ	VC=VCC,FULL=0.5V
FULL pin leak current	IFULLL	—	—	1	μA	FULL=3.3V
[Protection circuit block]						
UVLO detect voltage	VUVLOTH	1.95	2.1	2.25	V	VCC detection
UVLO hysteresis	VUVLOHYS	120	200	280	mV	
[IGBT driver block]						
Output short high current	I _{oso}	90	140	200	mA	IGBT_IN=3.3V,START=0V,IGBT_OUT=0V
Output short low current	I _{osi}	30	60	90	mA	IGBT_IN=0, START=0V,IGBT_OUT=3.3V
IGBT_IN input high voltage range1	VIGBTH	2	—	—	V	START=0V
IGBT_IN input high voltage range	VIGBTL	—	—	0.6	V	START=0V
IGBT_IN sink current	IIGBT_IN	12	24	36	μA	START=0V
IGBT_IN response time Rise	T _{res_rise1}	—	1	2	μs	IGBT_IN→IGBT_OUT response time(rise) START=0V
IGBT_IN response time Fall	T _{res_fall1}	—	120	200	ns	IGBT_IN→IGBT_OUT response time(fall) START=0V
IGBT_IN response time Rise	T _{res_rise2}	—	15	80	ns	IGBT_IN→IGBT_OUT response time(rise) START=3.3V
IGBT_IN response time Fall	T _{res_fall2}	—	120	200	ns	IGBT_IN→IGBT_OUT response time(fall) START=3.3V

©This product is not designed for normal operation within a radioactive environment

○ Block Diagram

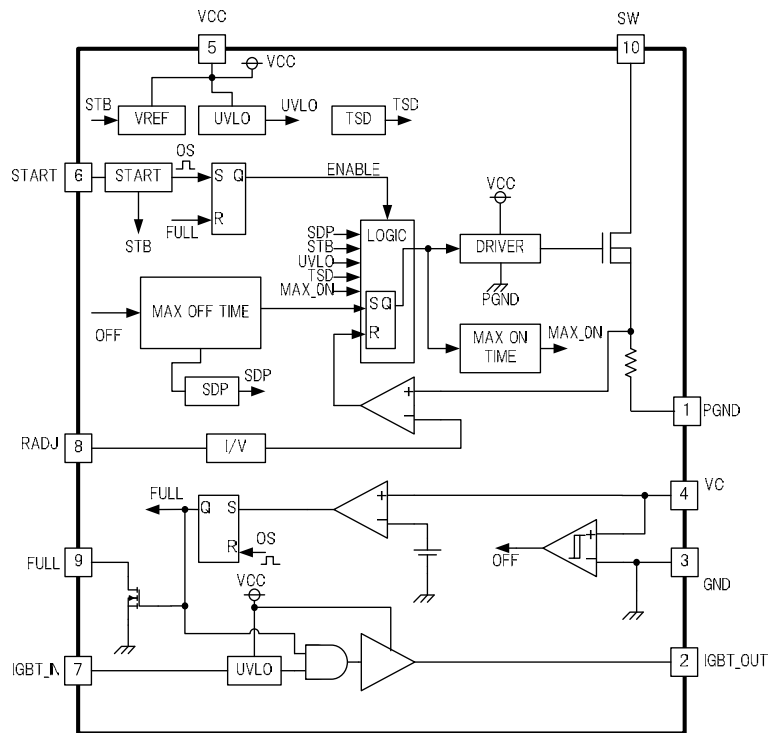

Fig.1 Block Diagram

○ Package (UNIT:mm)

○ Pin No.

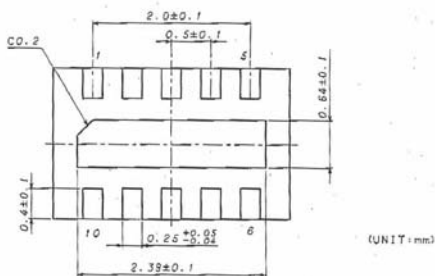
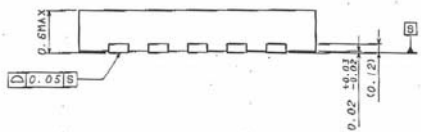
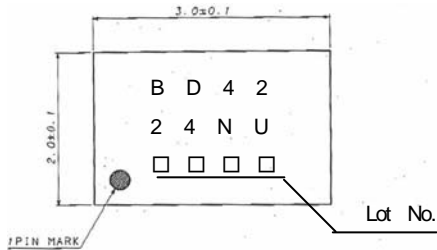

Fig. 2 Marking specification

Pin No.	Pin Name	Function
1	PGND	Power GND
2	IGBT_OUT	IGBT driver output
3	GND	Ground pin
4	VC	Secondary-side voltage detection pin
5	VCC	VCC supply pin
6	START	Standby pin
7	IGBT_IN	nput terminal of trigger signal for starting output of IGBT driver
8	RADJ	primary-side current control pin
9	FULL	FULL charge detection flag pin
10	SW	Switching pin

○ Cautions on use

1. Absolute maximum ratings
An excess in the absolute maximum ratings, such as supply voltage, temperature range of operating conditions, etc., can break down the devices, thus making impossible to identify breaking mode, such as a short circuit or an open circuit. If any over rated values will expect to exceed the absolute maximum ratings, consider adding circuit protection devices, such as fuses.
2. GND and PGND potential
Ensure a minimum GND and PGND(Except for SW pin and VC pin) pin potential in all operating conditions. In addition, ensure that no pins other than the GND and PGND pin carry a voltage less than or equal to the GND and PGND pin, including during actual transient phenomena.
Don't use VC pin under Absolute Maximum Rating.
3. Thermal design
Use a thermal design that allows for a sufficient margin in light of the power dissipation (Pd) in actual operating conditions.
4. Protect circuit
The IC does not incorporate built-in malfunction protection such as overcurrent protection, short detection, or thermal shutdown circuitry. For this reason, the IC may be damaged if it is shorted or subjected to a load that exceeds the package power. The design of peripheral application circuits should reflect these potential risks.
5. Inter-pin shorts and mounting errors
Use caution when positioning the IC for mounting on printed circuit boards. The IC may be damaged if there is any connection error or if positive and ground power supply terminals are reversed. The IC may also be damaged if pins are shorted together or are shorted to other circuit's power lines.
6. Common impedance
The power supply and ground lines must be as short and thick as possible to reduce line impedance. Fluctuating voltage on the power ground line may damage the device.
7. IC Pin Input
This is the monolithic IC and has P⁺ isolation and P substrate for element isolation between each element. By the P layer and N layer of each element, a P-N junction is formed and various parasitic elements are configured.
For example, in the case of a resistor and transistor being connected to a pin as shown in Fig.-3;
P-N junction operates as a parasitic diode when GND > (Pin A) in the case of the resistor, and when GND > (Pin B) in the case of the transistor (NPN)
Also, a parasitic NPN transistor operates by the N layer of another element adjacent to the previous diode in the case of a transistor (NPN) when GND > (Pin B).
The parasitic element consequently emerges through the potential relationship because of IC's structure. The parasitic element pulls interference out of the circuit which may be the cause of malfunction or destruction. Therefore, excessive caution is required to avoid operation of the parasitic element which is caused by applying voltage to an input pin lower than GND (P board), etc.
8. SW pin absolute maximum voltage of AC pulse
Ensure that SW pin carry a voltage less than 53V, when SW pin stopped charge condition.

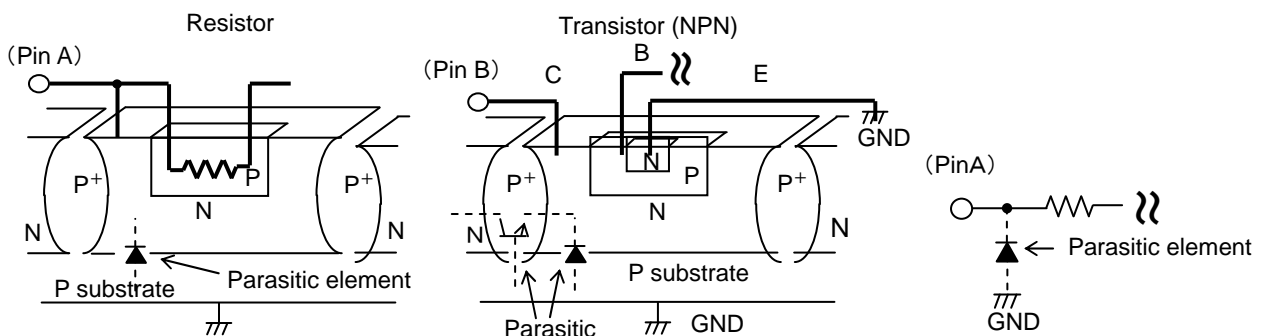

Fig.3 Other adjacent elements

Notes

No copying or reproduction of this document, in part or in whole, is permitted without the consent of ROHM Co.,Ltd.

The content specified herein is subject to change for improvement without notice.

The content specified herein is for the purpose of introducing ROHM's products (hereinafter "Products"). If you wish to use any such Product, please be sure to refer to the specifications, which can be obtained from ROHM upon request.

Examples of application circuits, circuit constants and any other information contained herein illustrate the standard usage and operations of the Products. The peripheral conditions must be taken into account when designing circuits for mass production.

Great care was taken in ensuring the accuracy of the information specified in this document. However, should you incur any damage arising from any inaccuracy or misprint of such information, ROHM shall bear no responsibility for such damage.

The technical information specified herein is intended only to show the typical functions of and examples of application circuits for the Products. ROHM does not grant you, explicitly or implicitly, any license to use or exercise intellectual property or other rights held by ROHM and other parties. ROHM shall bear no responsibility whatsoever for any dispute arising from the use of such technical information.

The Products specified in this document are intended to be used with general-use electronic equipment or devices (such as audio visual equipment, office-automation equipment, communication devices, electronic appliances and amusement devices).

The Products specified in this document are not designed to be radiation tolerant.

While ROHM always makes efforts to enhance the quality and reliability of its Products, a Product may fail or malfunction for a variety of reasons.

Please be sure to implement in your equipment using the Products safety measures to guard against the possibility of physical injury, fire or any other damage caused in the event of the failure of any Product, such as derating, redundancy, fire control and fail-safe designs. ROHM shall bear no responsibility whatsoever for your use of any Product outside of the prescribed scope or not in accordance with the instruction manual.

The Products are not designed or manufactured to be used with any equipment, device or system which requires an extremely high level of reliability the failure or malfunction of which may result in a direct threat to human life or create a risk of human injury (such as a medical instrument, transportation equipment, aerospace machinery, nuclear-reactor controller, fuel-controller or other safety device). ROHM shall bear no responsibility in any way for use of any of the Products for the above special purposes. If a Product is intended to be used for any such special purpose, please contact a ROHM sales representative before purchasing.

If you intend to export or ship overseas any Product or technology specified herein that may be controlled under the Foreign Exchange and the Foreign Trade Law, you will be required to obtain a license or permit under the Law.



Thank you for your accessing to ROHM product informations.
More detail product informations and catalogs are available, please contact us.

ROHM Customer Support System

<http://www.rohm.com/contact/>